

WINDOW

# Electric smoke and heat extraction and ventilation systems

# Contents

Overview	04
Installation options	05

## OPENING DRIVES

### Chain drives

ECchain	08
E 740	14
Slimchain	25
Slimchain 230 V	40
Powerchain	53

### Spindle drives

E 250 NT	65
E 350 N	73
E 1500 N	79
E 1500 S	86
E 3000	90

### Electric linear and scissor drives

E 212	95
E 170	99
E 170/2	104
Variable cover for E 170	110

## LOCKING DRIVES

Power lock	114
E 90X	118

## OPENING AND LOCKING SYSTEMS

RWA 100 NT	124
OL 350 EN	128
RWA 105 NT	131
OL 370 EN	136
RWA 110 NT	139
OL 360 EN	143
RWA EM "OPEN"	146

**AIR INTAKE**

RWA TÖ	152
RWA K 600 G	156
RWA K 600 T	162
RWA K 600 F	166
RWA AUT	170

**SMOKE AND HEAT EXTRACTION CONTROL**

MBZ 300	176
THZ	184
THZ Comfort	187
E 260 N8/2	190
Possible combinations of control panels with on-site systems	193

**NETWORKING**

IQ box KNX	196
------------	-----

**ACCESSORIES**

Smoke and heat extraction system	202
Ventilation	204
Sensors	208
Power supplies	210
Surface-mounted housings	212
Marking / signalisation	213
Safety scissor stays	214
Synchronising units	217

**SOFTWARE**

WinCalc calculation programme	220
-------------------------------	-----

OVERVIEW

	Chain drives					Spindle drives					Locking drives		Opening and locking systems					Electro-magnetic linear and scissor drives		Air intake				
	ECchain E 740	Slimchain	Slimchain 230 V	Powerchain		E 250 NT	E 350 N	E 1500 N	E 1500 S	E 3000	Power lock E 90X		RWA 100 NT	OL 350 EN	RWA 105 NT	OL 370 EN	RWA 110 NT	OL 360 EN	RWA-EM	E 212	E 170, E 170/2	RWA TÖ	RWA K 600	RWA AUT

AREA OF APPLICATION

Natural ventilation	●	●	●	●	●	●	●	●	●	●	●	●	●	●	●	●	●	●			●	●		●	
Smoke and heat extraction system		●		●		●		●	●	●	●	●	●		●		●		●			● <sup>2</sup>	●	●	●
SHEV according to EN 12101-2		●		●		●			●	●	●	●	●		●		●							●	

FUNCTION

Exhaust air (as smoke extraction (SHEV according to EN 12101-2) or smoke dissipation)		●	●	●		●		●	●	●	●	●	●		●		●		●			● <sup>2</sup>		●	
Fresh air		●	●	●		●		●			●	●	●		●		●		●			● <sup>2</sup>	●	●	●

APPLICATION LOCATION

Façade	●	●	●	●	●	●	●	●			●	●	●	●	●	●	●	●	●	●	●			●	
Roof		●		●		●	●	●	●	●														● <sup>5</sup>	
Door																							●	●	●

LEAF TYPES

Bottom-hung leaf	●	●	●	●	●	●	●	●			●	●	●	●	●	●	●	●	●	●	●	●	●	●
Side-hung leaf	●	●	●	●	●	●	●	●			●	●	●	●	●	●	●	●	●					●
Top-hung leaf	●	●	●	●	●	●	●	●			●	●	●	●	●	●	●	●	●					●
Centre pivoted leaf		●		●							●	●												
Vertically centre pivoted leaf		●		●							●	●												
Skylight leaf		●		●		●	●	●	●	●														
Louvre window						●	●													●				
Projected top hung leaf		●	●																					
Parallel opening window		●																						

TYPE OF OPENING

Inward opening	●	●	●	●	●	●	●	●			●	●	●	●	●	●	●	●	●	●	●	●	●	●	
Outward opening	●	●	●	●	●	●	●	●	●	●													●	●	●

INSTALLATION OPTIONS

Frame	●	●	●	●	●	●	●	●	●	●	●		●	●	●	●	●	●	●	●	●	●	●	●
Leaf		●	●	●	●	●	●	●			●			●	●				●				●	●
Integrated		● <sup>6</sup>	● <sup>6</sup>								●													

OPENING WIDTH [MM] / OPENING ANGLE [°]

	200	100	300	200	600	100	100	300	500	500	22 <sup>1)</sup>	18 <sup>7)</sup>	58 <sup>1)</sup>	52 <sup>1)</sup>	75 <sup>1)</sup>	75 <sup>1)</sup>	56 <sup>1)</sup>	56 <sup>1)</sup>			170		90
	400	200	500	300	800	150	150	400	750	750													
	300	800	500	1200	200	200	500	1000	1000														
	400	800	230	230	750																		
			300	300	1000																		
			500	500																			
			750	700																			
			1000	750																			
			1000																				

CONNECTION TO CONTROL PANELS

THZ / THZ Comfort		●	●	●	●		●			●	●	●		●		●		● <sup>4</sup>		● <sup>2</sup>		●	●	● <sup>3</sup>
E 260 N		●	●	●	●		●	●	●	●	●	●		●		●				● <sup>2</sup>		● <sup>5</sup>	●	● <sup>3</sup>
MBZ 300		●	●	●	●		●	●	●	●	●	●		●		●		● <sup>4</sup>		● <sup>2</sup>		●	●	● <sup>3</sup>

USE FOR VENTILATION 230 V

with power supply and IQ gear		●		●	●					●	●	●		●		●								
-------------------------------	--	---	--	---	---	--	--	--	--	---	---	---	--	---	--	---	--	--	--	--	--	--	--	--

1 = max. opening angle depending on window size | 2 = only 24 V version | 3 = no supply - only potential-free alarm contact | 4 = mode of operation "hold-open magnet" | 5 = depending on application | 6 = special variant, planning separate, profile-dependent | 7 = locking stroke



**INSTALLATION OPTIONS**

**BOTTOM-HUNG LEAF INWARD OPENING**

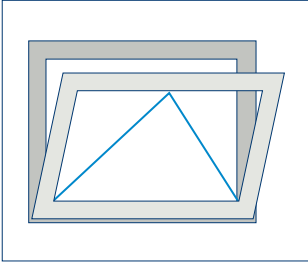

ECchain, E 740, Slimchain, Slimchain 230 V, Powerchain E 250 NT, E 350 N, E 1500, Power lock, E 90X, RWA 100 NT, RWA 105 NT, OL 350 EN, OL 370 EN, E 170, E 170/2, E 212, RWA K 600 G, RWA K 600 F

**SIDE-HUNG LEAF INWARD OPENING**

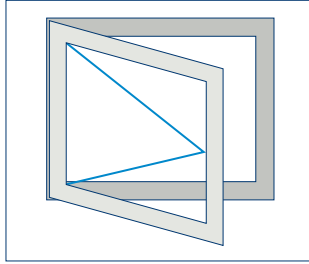

ECchain, E 740, Slimchain, Slimchain 230 V, Powerchain E 250 NT, E 350 N, E 1500 Power lock, E 90X, RWA 100 NT, RWA 105 NT, OL 350 EN, OL 370 EN, RWA K 600 G, RWA K 600 F

**TOP-HUNG LEAF INWARD OPENING**

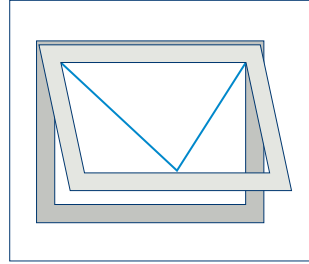

E 740, Slimchain, Slimchain 230 V, Powerchain, E 250 NT, E 350 N, E 1500, Power lock RWA 100 NT, RWA 105 NT, OL 350 EN, OL 370 EN, RWA K 600 G, RWA K 600 F

**BOTTOM-HUNG LEAF OUTWARD OPENING**

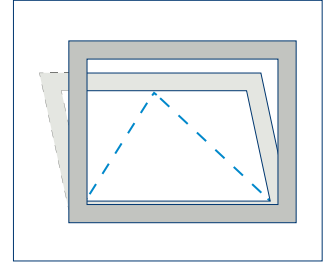

E 740, Slimchain, Slimchain 230 V, Powerchain, E 250 NT, E 350 N, E 1500, RWA 110 NT, OL 360 EN, RWA K 600 G

**SIDE-HUNG LEAF OUTWARD OPENING**

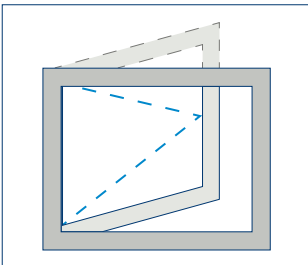

ECchain, E 740, Slimchain, Slimchain 230 V, Powerchain E 250 NT, E 350 N, E 1500 RWA 110 NT / OL 360 EN RWA K 600 G

**TOP-HUNG LEAF OUTWARD OPENING**

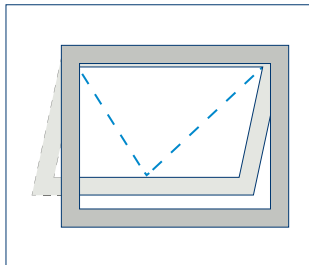

ECchain, E 740, Slimchain, Slimchain 230 V, Powerchain E 250 NT, E 350 N, E 1500, RWA 110 NT, OL 360 EN RWA K 600 G

**VERTICALLY CENTRE PIVOTED LEAF LEFT INWARD OPENING**

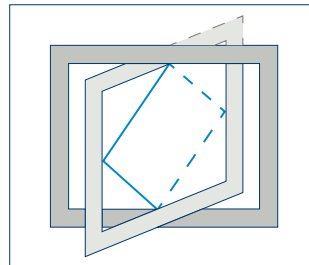

E 740, Powerchain, Power lock, Special windows on request

**CENTRE PIVOTED LEAF BOTTOM INWARD OPENING**

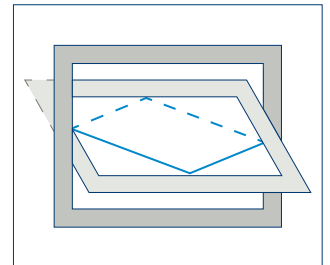

E 740, Powerchain, Power lock

**SKYLIGHT LEAF OUTWARD OPENING**

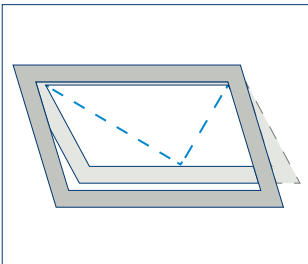

E 740, Powerchain, E 250 NT, E 350 N, E 1500 N, E 3000

**VERTICALLY CENTRE PIVOTED LEAF RIGHT INWARD OPENING**

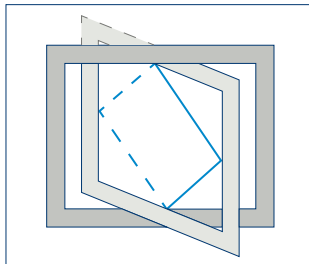

E 740, Powerchain, Power lock

**CENTRE PIVOTED LEAF BOTTOM OUTWARD OPENING**

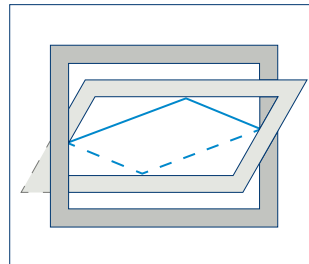

E 740, Powerchain

**LOUVRE WINDOW**

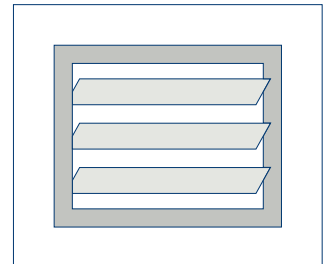

E 250 NT, E 350 NT, E 212

**PROJECTED TOP HUNG LEAF OUTWARD OPENING**

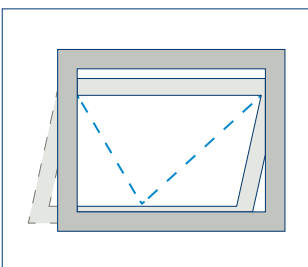

Slimchain, Slimchain 230 V

**PARALLEL OPENING WINDOW (PAF) OUTWARD OPENING**

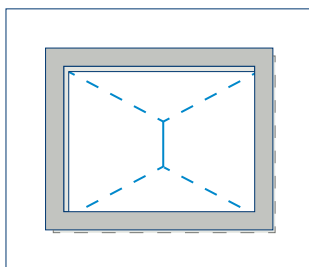

Slimchain

**DOOR**

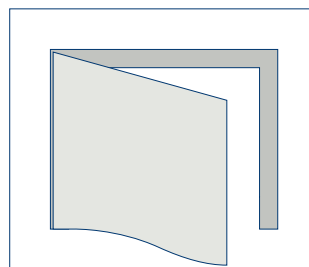

RWA K 600 T, RWA AUT, RWA TÖ



## WINDOW

# Opening drives

Electric opening drives relieve you of the opening and closing of windows. Especially when mechanical ventilation requires too much manual force or is not possible at all. Opening drives for windows offer both: Safety in case of danger and ventilation comfort in everyday life. Automated windows with chain or spindle drives serve as a smoke and heat extraction opening in case of fire. As a side effect, they serve the purpose of providing controlled daily ventilation and take on the function of a window ventilation system.



# ECchain



Chain drive with universal consoles  
for simple automation in ventilation mode

## AREAS OF APPLICATION

- Natural ventilation (230 V) also for private residential construction
- Inward and outward opening bottom-, top- and side-hung windows
- Installation on wooden, PVC or aluminium windows
- Frame installation

## PRODUCT FEATURES

- Cost-effective and powerful chain drive for 230 V ventilation applications
- Variable stroke adjustment to 200 mm or 400 mm possible for different ventilation requirements
- Universal fixtures and consoles for standard profile systems available on the market
- Fast and simple installation
- Can be used variably on small skylights

## TECHNICAL DATA

### ECchain

#### GENERAL INFORMATION

Length	with console 409 mm, without console 390 mm
Height	44 mm
Depth	63 mm
Space needed on frame (min.)	frame installation inward opening: 55 mm, frame installation outward opening: 35 mm
Space needed on leaf (min.)	frame installation inward opening: 37 mm, frame installation outward opening: 20 mm

#### SPECIFICATIONS

Possible stroke lengths	200 mm, 400 mm
Stroke length selectable	yes, stroke 200 or stroke 400 mm depending on cable connection
Opening speed ventilation	9 mm/s
Closing speed	9 mm/s
Tensile force (max.)	250 N
Compressive force (max.)	250 N
Holding force (max.)	1800 N
Leaf weight (max.)	200 kg *
Overlap range	10 – 23 mm

#### ELECTRICAL DATA

Operating voltage	230 V ± 10 %
Current consumption	0.13 A
Duty rating	30 %
Length of power supply cable	2 m
Cable dimensions	4 x 0.75 mm <sup>2</sup>
Temperature range	-5 – 60 °C
IP rating / protection rating	IP30 / II

#### FUNCTIONS

End position cut-off extended	limit switch
End position cut-off retracted	electric, electronic via current consumption
Overload cut-off	●

#### TYPES OF INSTALLATION

Bottom-hung window	inward opening	frame
Side-hung window	inward opening	frame
	outward opening	frame
Top-hung window	outward opening	frame

● = YES | \* The overall weight is limited by the hinges and depends on the details provided by the profile system manufacturer

## PRODUCT SCALE DRAWING

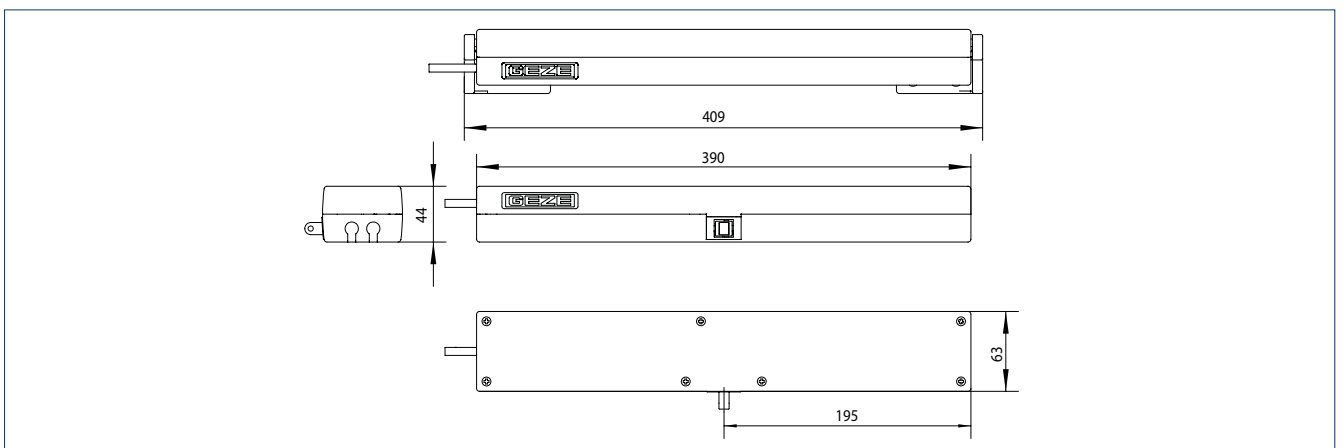

## TYPES OF INSTALLATION

Frame installation  
INWARD opening

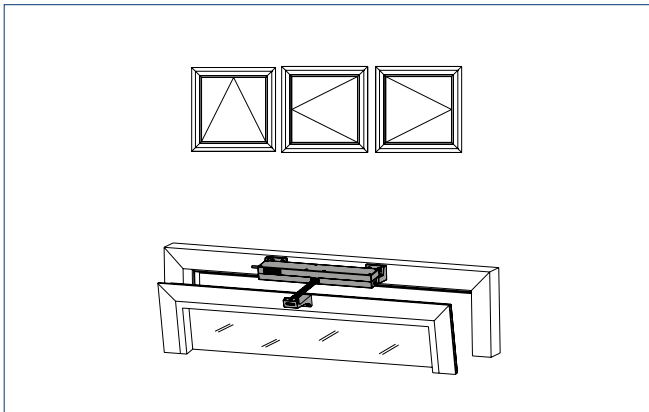

Frame installation  
OUTWARD opening

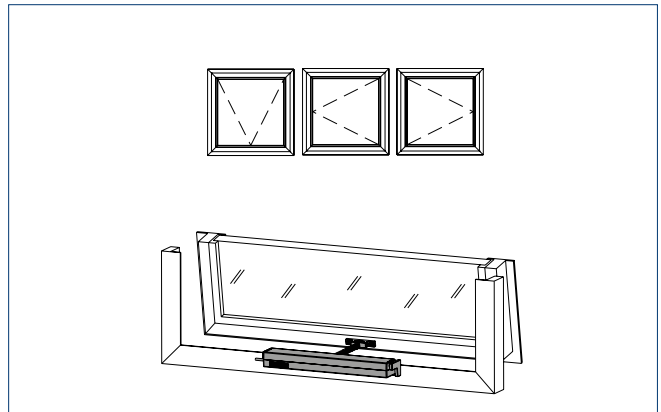

## FORCE-PATH CHART

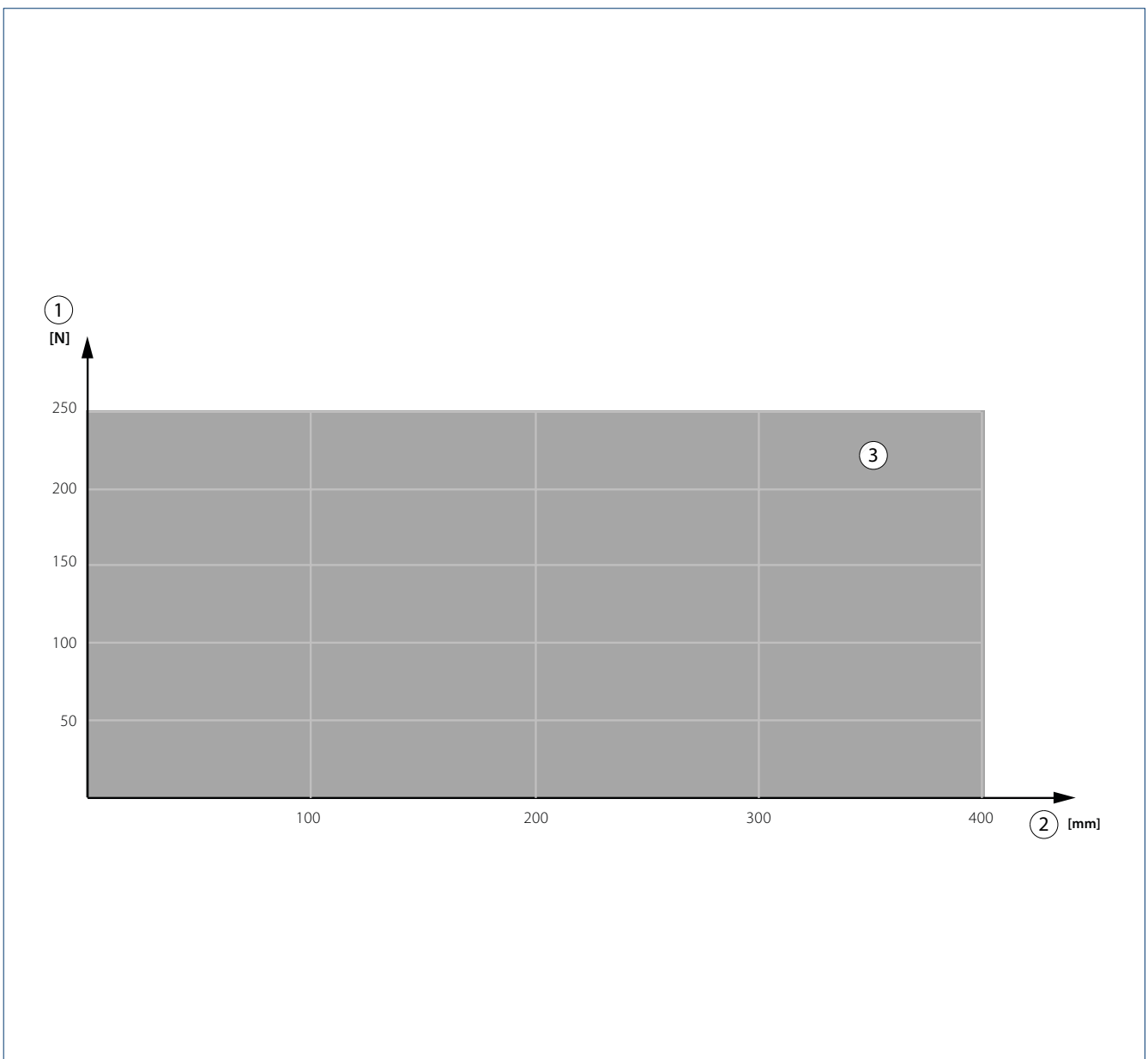

1 = Force | 2 = Stroke | 3 = Tension / pressure

**AREA OF APPLICATION BOTTOM-HUNG WINDOW FRAME INSTALLATION INWARD OPENING**

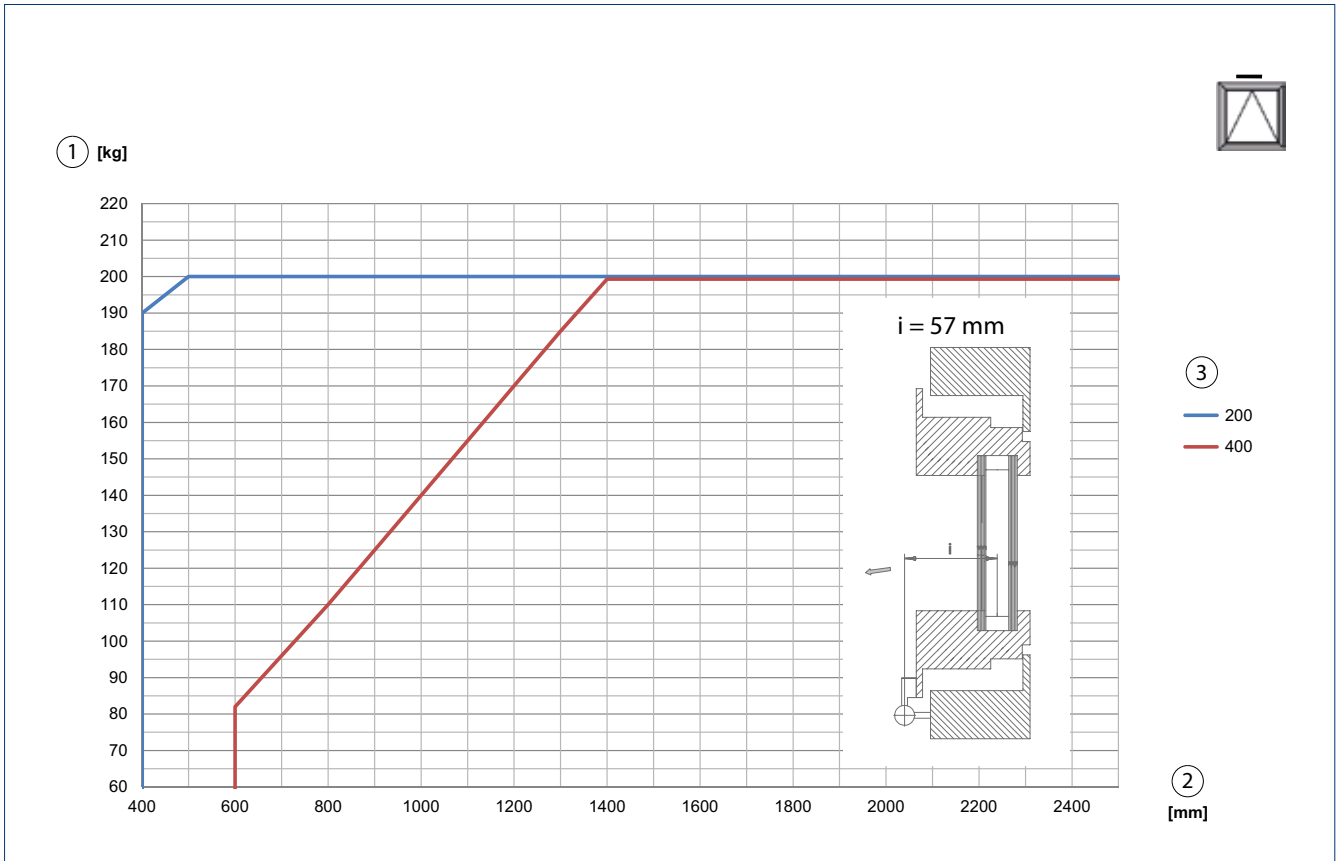

1 = Leaf weight | 2 = Secondary closing edge | 3 = Stroke

**OPENING ANGLE BOTTOM-HUNG WINDOW FRAME INSTALLATION INWARD OPENING**

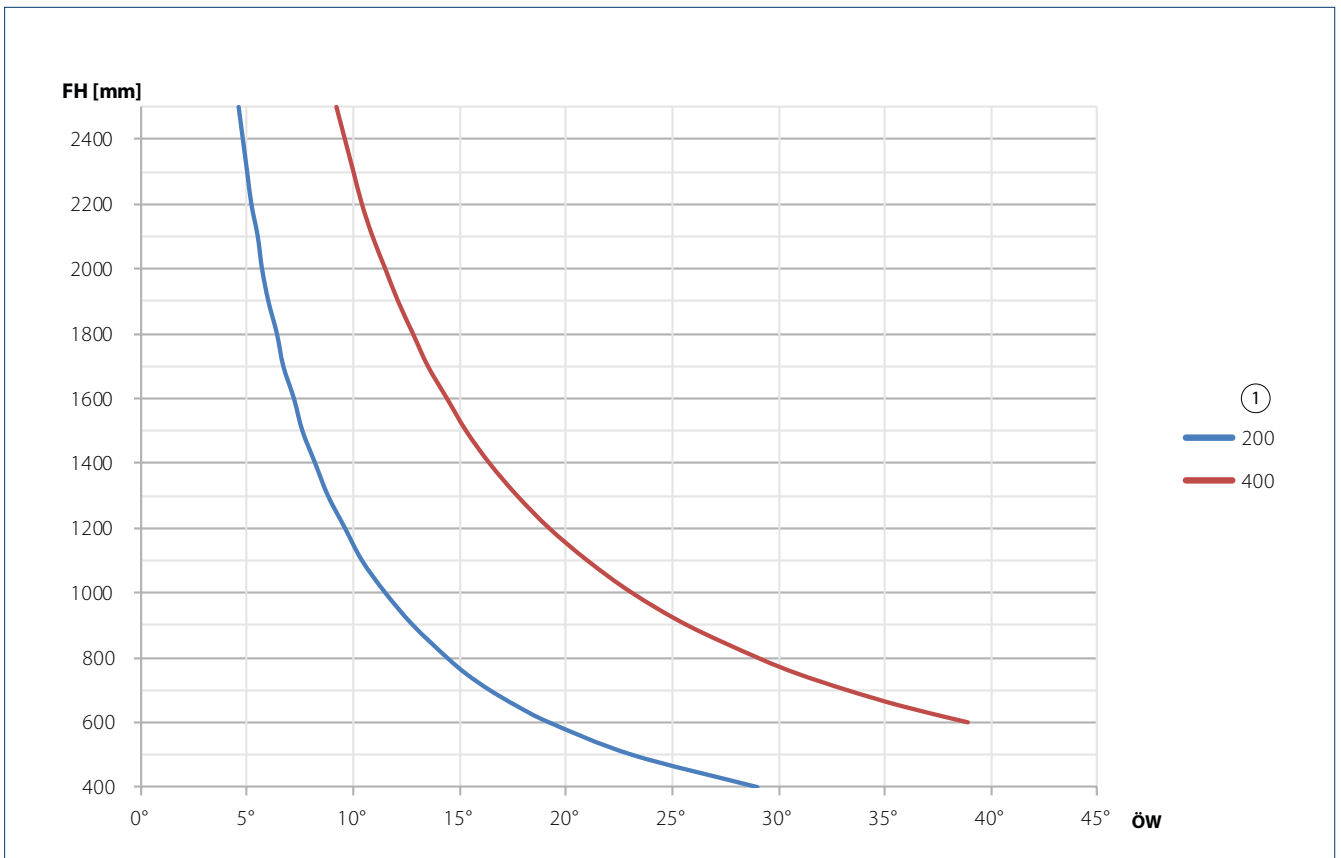

FH = Leaf height | öw = Opening angle | 1 = Stroke

AREA OF APPLICATION TOP-HUNG WINDOW FRAME INSTALLATION OUTWARD OPENING

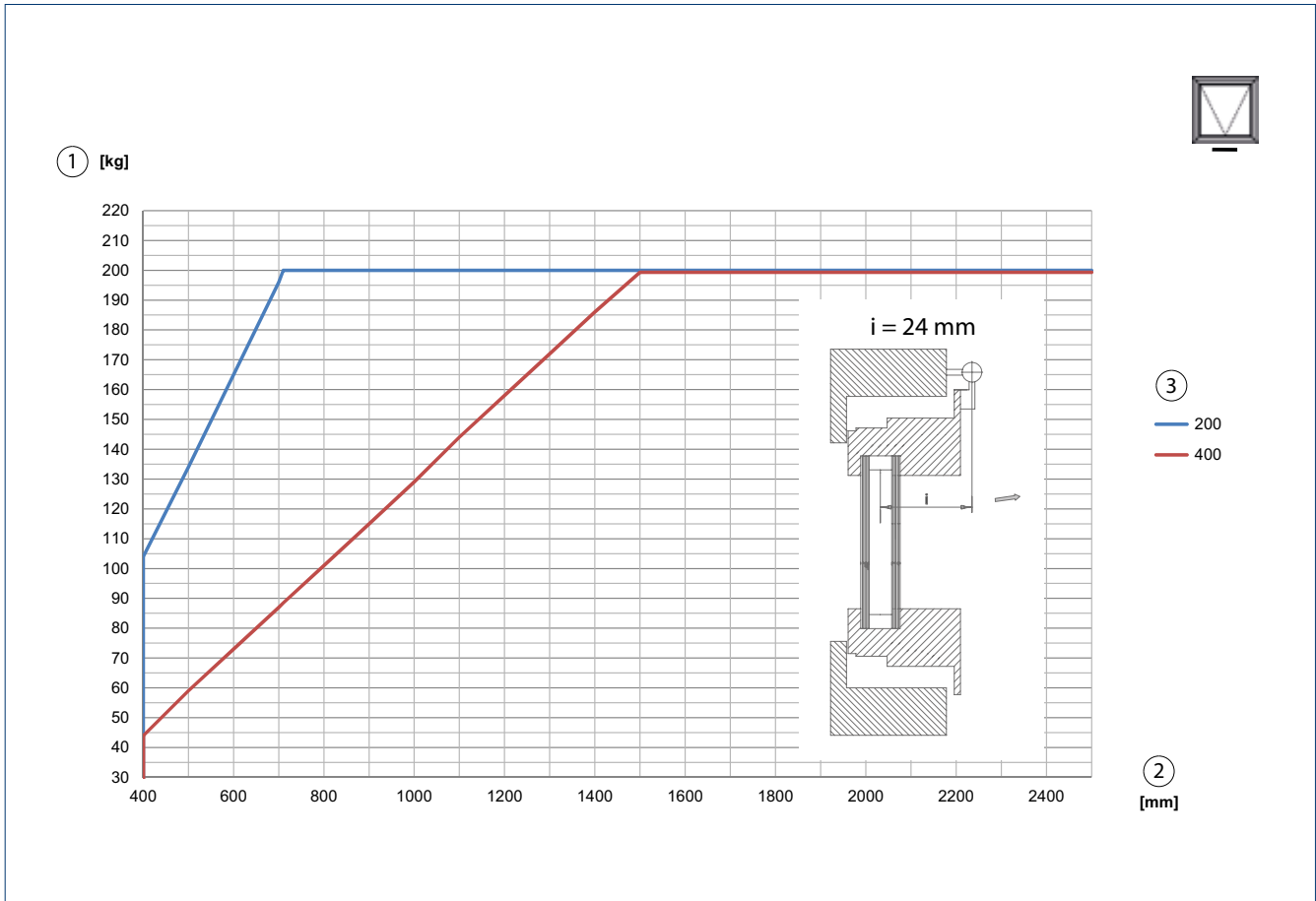

1 = Leaf weight | 2 = Secondary closing edge | 3 = Stroke

OPENING ANGLE TOP-HUNG WINDOW FRAME INSTALLATION OUTWARD OPENING

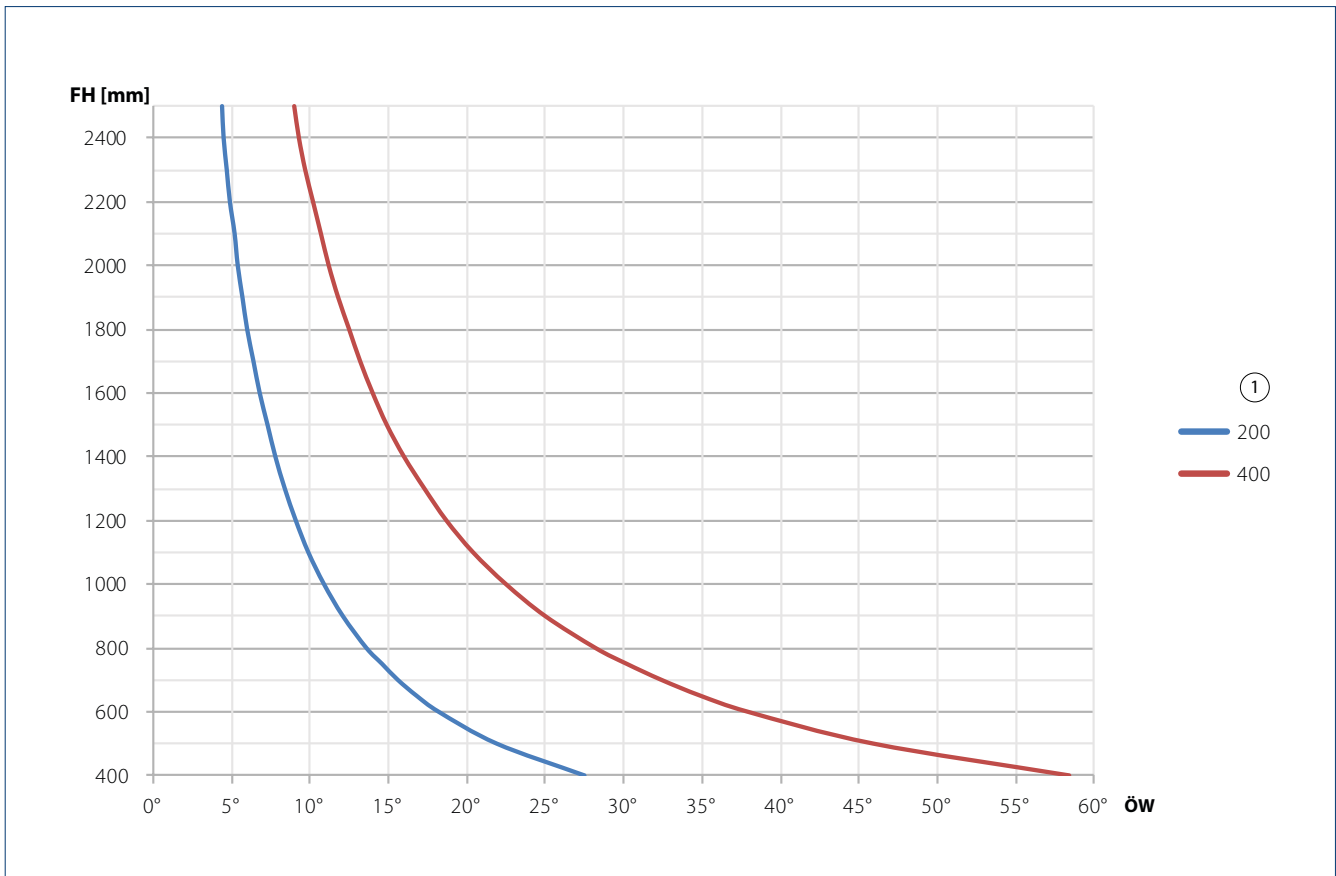

FH = Leaf height | ÖW = Opening angle | 1 = Stroke



**SPACE NEEDED**

**SPACE NEEDED FOR FRAME INSTALLATION INWARD OPENING**

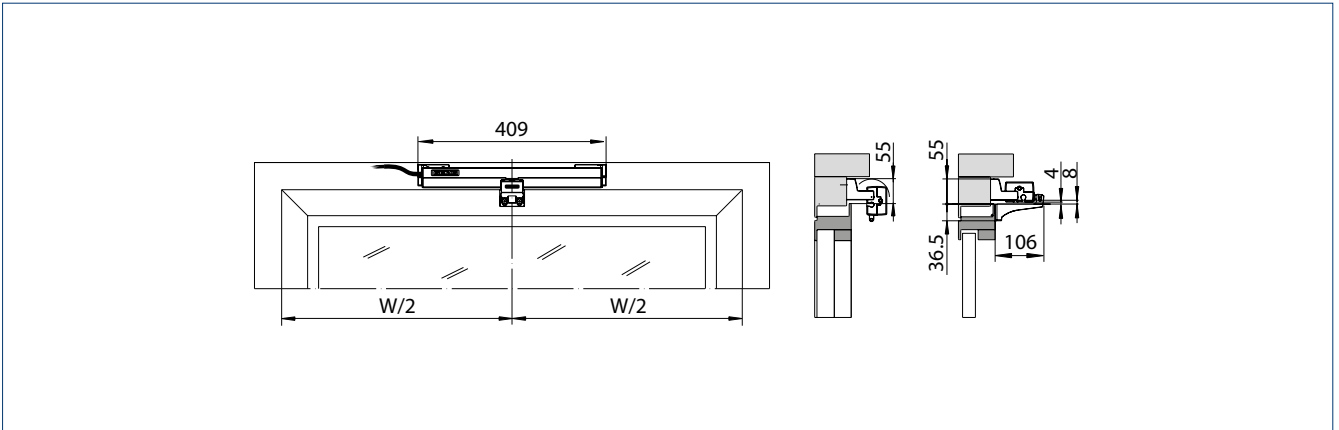

**SPACE NEEDED FOR FRAME INSTALLATION OUTWARD OPENING**

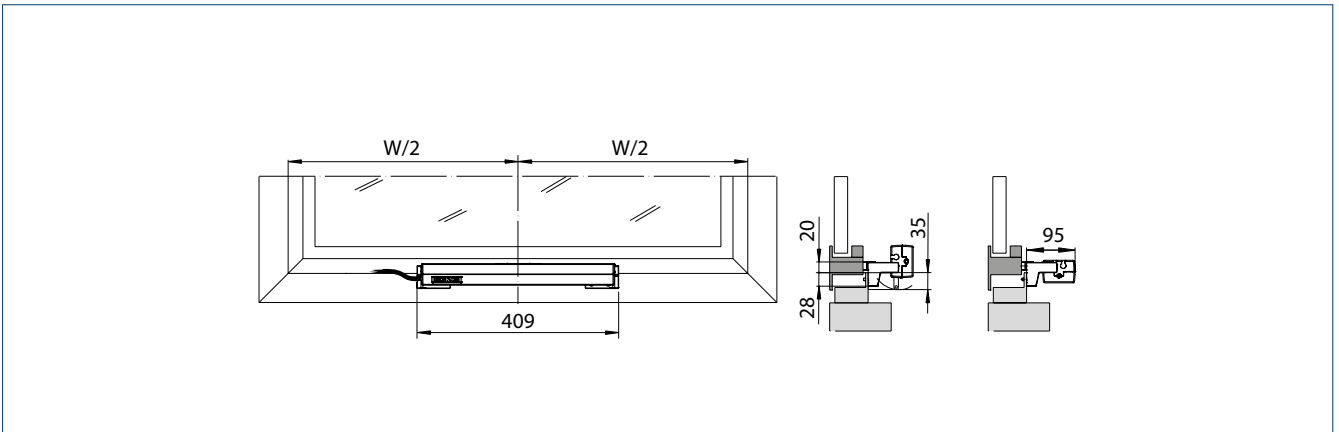

Frame installation  
INWARD opening

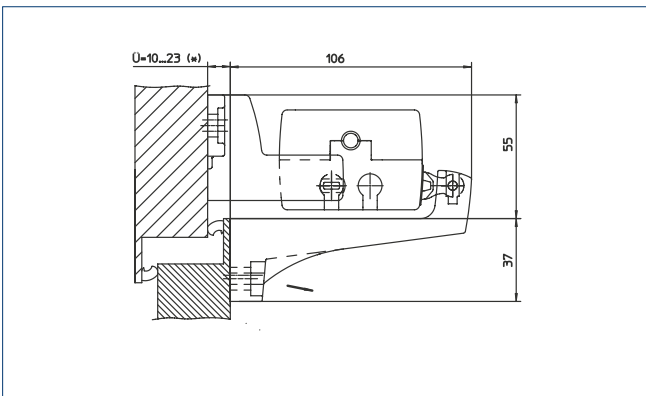

Frame installation  
OUTWARD opening

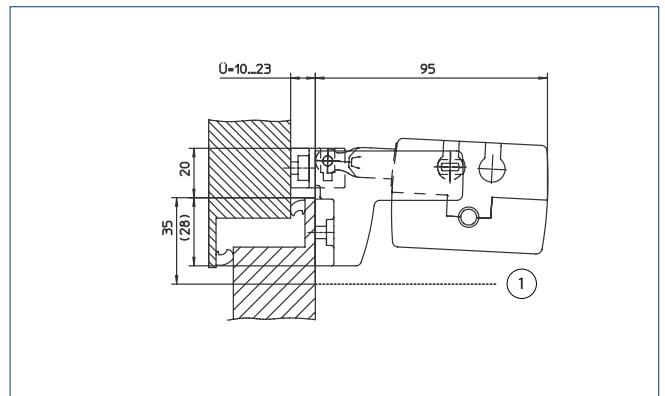

→ **Note:** The space needed for the drive depends on the type of installation.  
U = Overlap range | 1 = Swivel range

**ORDER INFORMATION**

Designation	Version	ID no.
ECchain including console for inward and outward opening	white	148260
	black	148258
	grey	148259

# E 740



## Chain drive for daily ventilation in the 230 V range

### AREAS OF APPLICATION

- Natural ventilation (230 V) in the façade and roof area
- Inward and outward opening bottom-hung, top-hung, side-hung and centre pivoted windows
- Outward opening roof windows and skylight domes
- Inward opening vertically centre pivoted windows
- Installation on wooden, PVC or metal windows
- Quick and easy installation from the front
- Leaf and frame installation

### PRODUCT FEATURES

- Aluminium housing and compact design
- Variable stroke adjustment via rotary switch from outside on the drive
- Available as Solo version (single operation) and Syncro version (multiple operation)
- Synchronized multiple operation of up to four drives
- Quick and easy installation

**TECHNICAL DATA****E 740****GENERAL INFORMATION**

Length	423 mm incl. console
Height	42 mm
Depth	54 mm

**SPECIFICATIONS**

Possible stroke lengths	100 mm, 200 mm, 300 mm, 400 mm
Opening speed ventilation	7 mm/s
Closing speed	7 mm/s
Tensile force (max.)	300 N
Compressive force (max.)	250 N
Holding force (max.)	1800 N
Leaf weight (max.)	150 kg *
Overlap range	0 – 25 mm

**ELECTRICAL DATA**

Operating voltage	230 V ± 10 %
Current consumption	0.13 A
Power consumption (max.)	30 W
Duty rating	30 %
Length of power supply cable	2 m
Cable dimensions	3 x 0.75 mm <sup>2</sup> / Syncro 5 x 0.75 mm <sup>2</sup>
Temperature range	-5 – 70 °C
IP rating/protection rating	IP42 / II

**FUNCTIONS**

Stroke length settable	rotary switch on the drive
Syncro	●
Additional locking device available	●
End position cut-off extended	internal path sensor
End position cut-off retracted	current consumption
Overload cut-off	●

**TYPES OF INSTALLATION**

Bottom-hung window	inward opening outward opening	frame/leaf frame
Side-hung window	inward opening outward opening	frame/leaf frame
Top-hung window	inward opening outward opening	frame/leaf frame
Roof window	outward opening	frame
Centre pivoted window	inward opening outward opening	frame frame
Vertically centre pivoted window	inward opening	frame

● = YES | \* The overall weight is limited by the hinges and depends on the details provided by the profile system manufacturer

## PRODUCT SCALE DRAWING

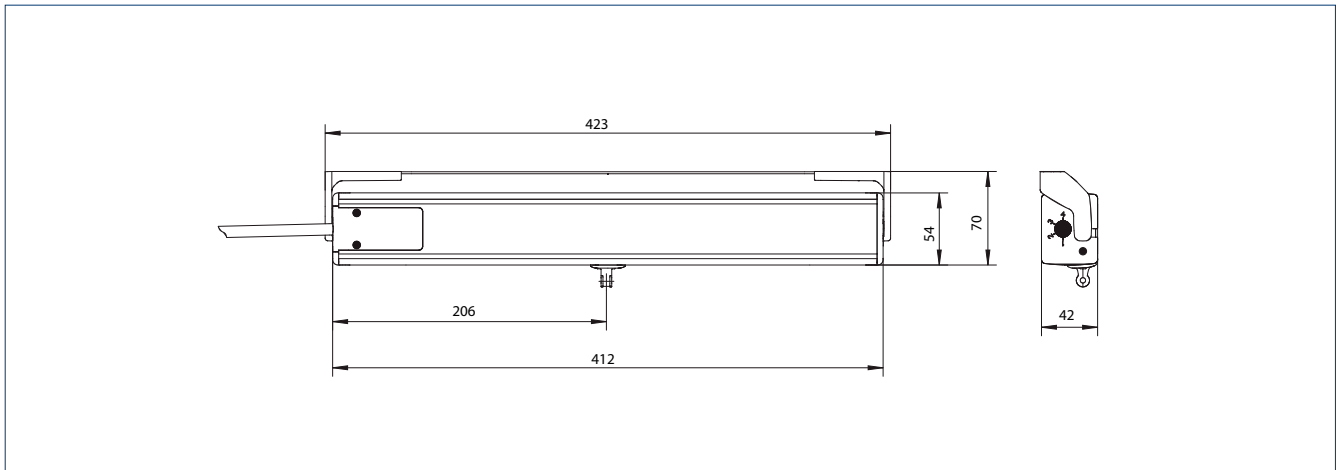

## TYPES OF INSTALLATION

Frame installation  
INWARD opening

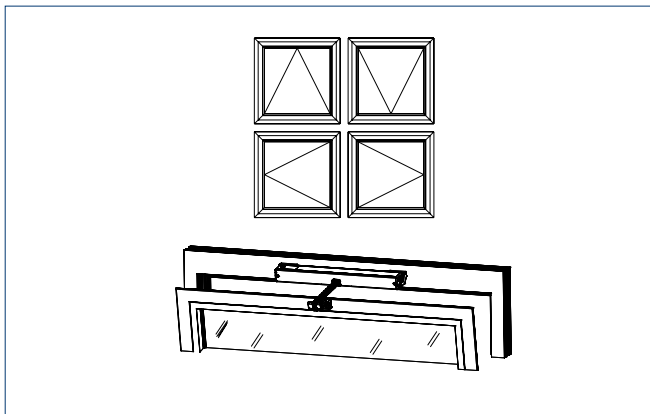

Leaf installation  
INWARD opening

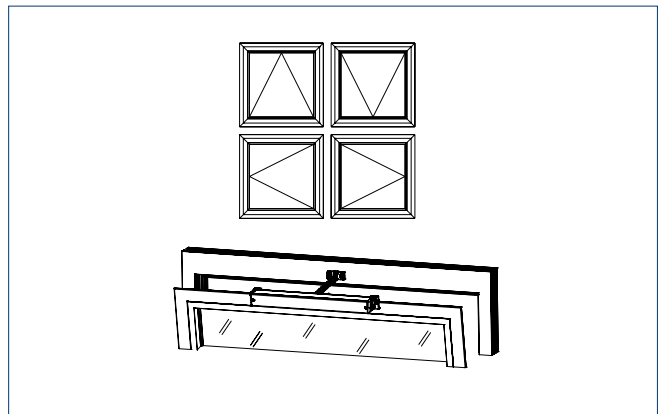

Frame installation  
OUTWARD opening

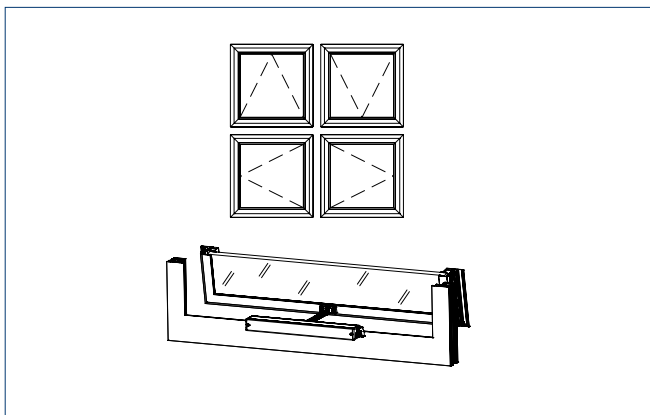

Skylight leaf  
Frame installation  
OUTWARD opening

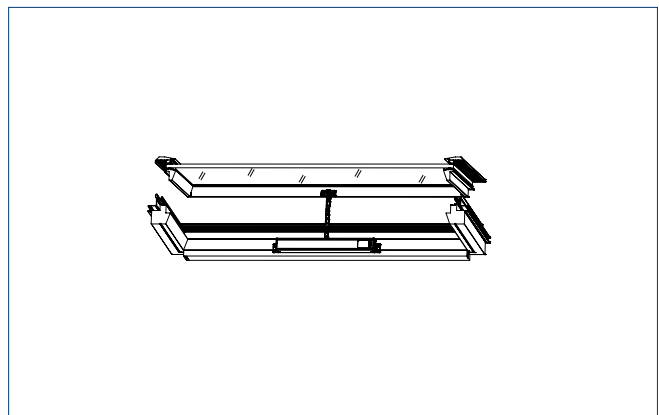

Frame installation  
INWARD opening

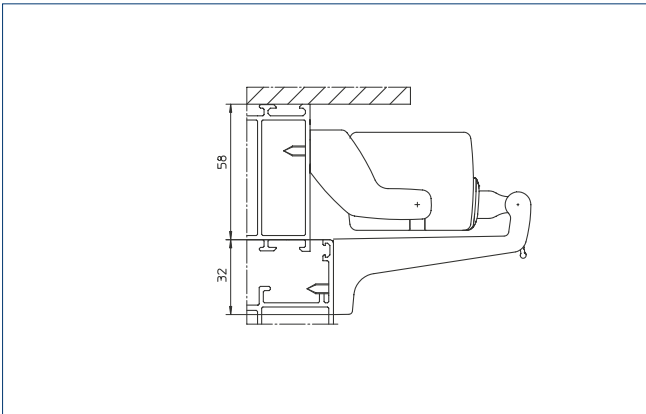

Frame installation  
INWARD opening, with swivel bracket

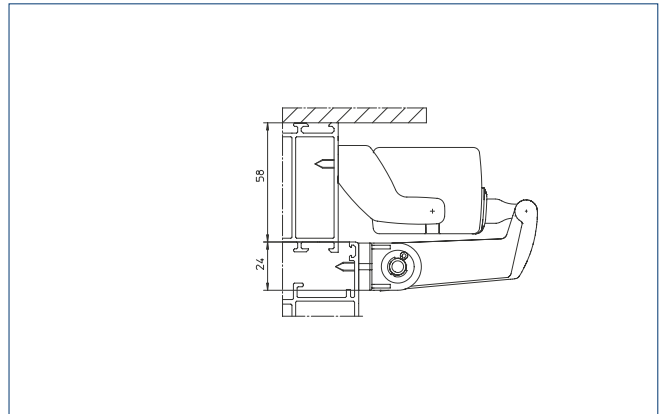

Leaf installation  
INWARD opening

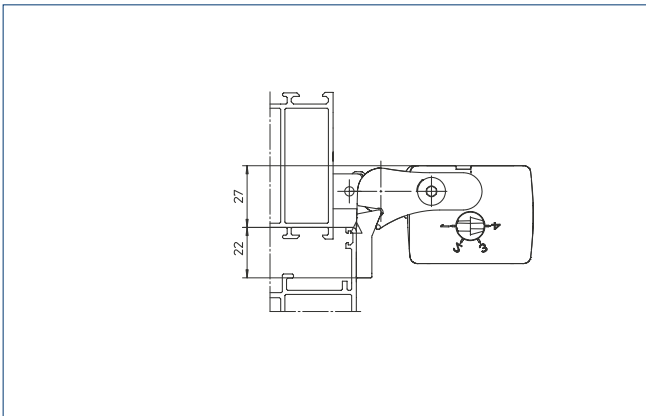

Frame installation  
OUTWARD opening

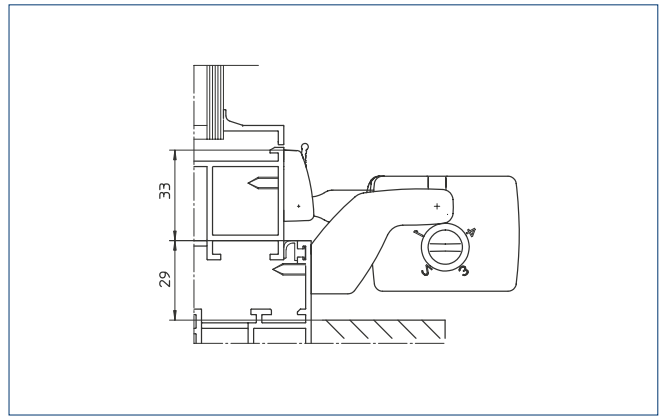

→ **Note:** The space needed for the drive depends on the type of installation.

### FORCE-PATH CHART

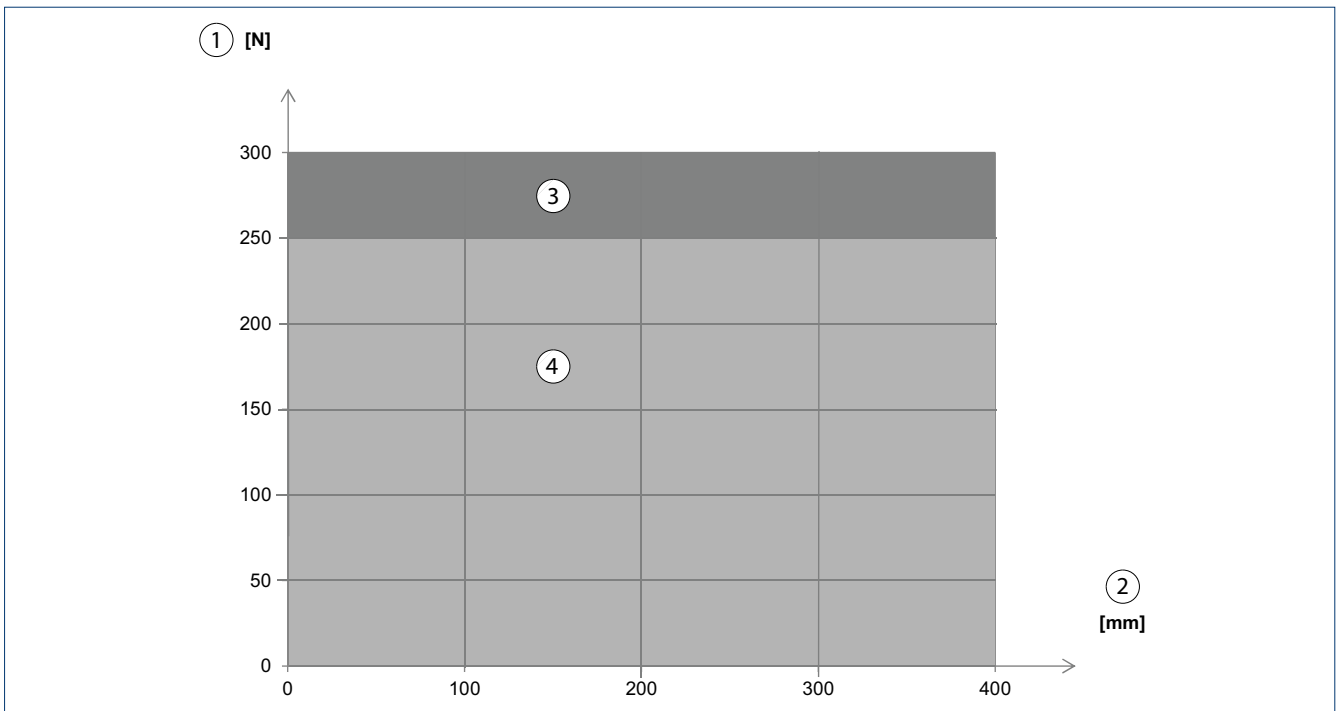

1 = Force | 2 = Stroke | 3 = Tension | 4 = Pressure

AREA OF APPLICATION BOTTOM-HUNG WINDOW FRAME INSTALLATION INWARD OPENING

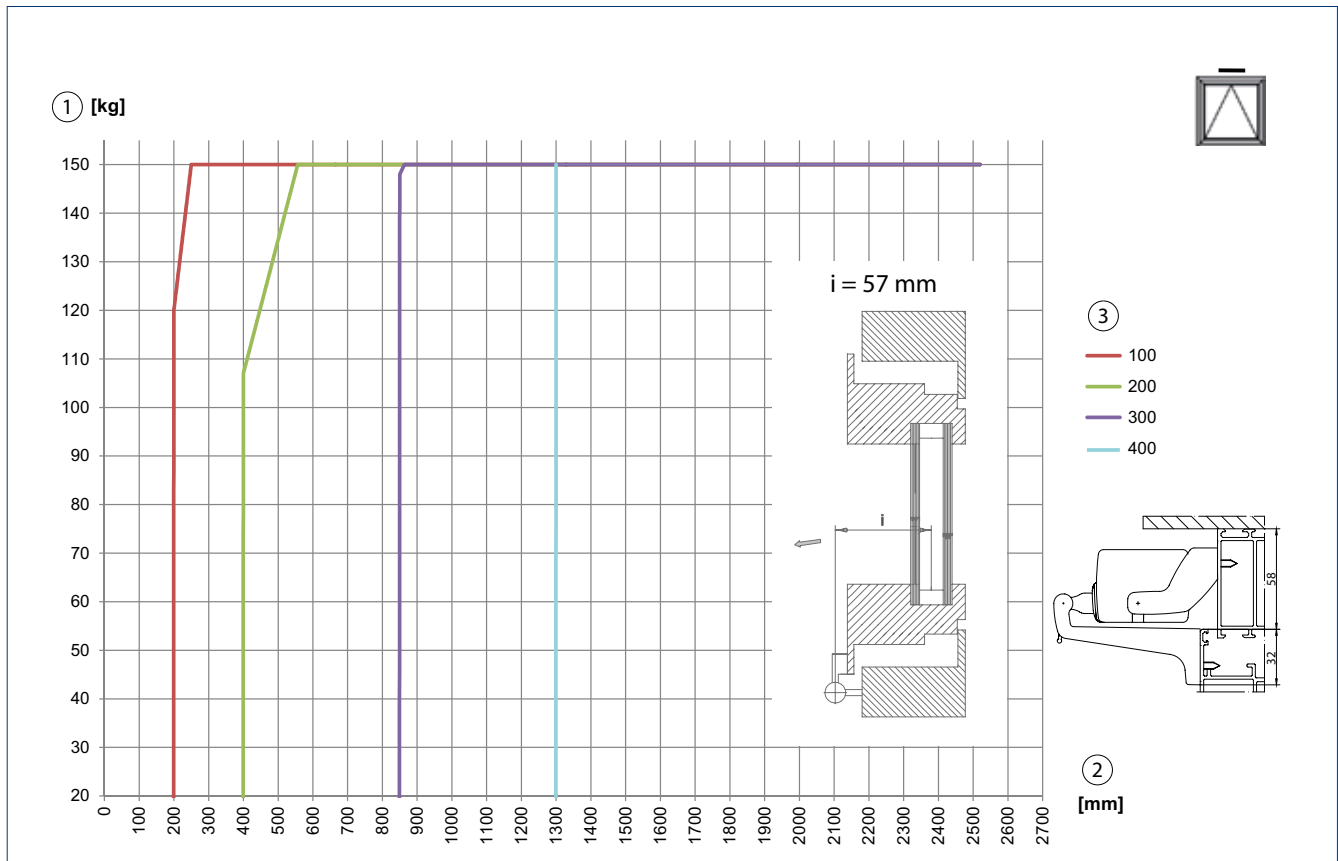

1 = Leaf weight | 2 = Secondary closing edge | 3 = Stroke

OPENING ANGLE BOTTOM-HUNG WINDOW FRAME INSTALLATION INWARD OPENING

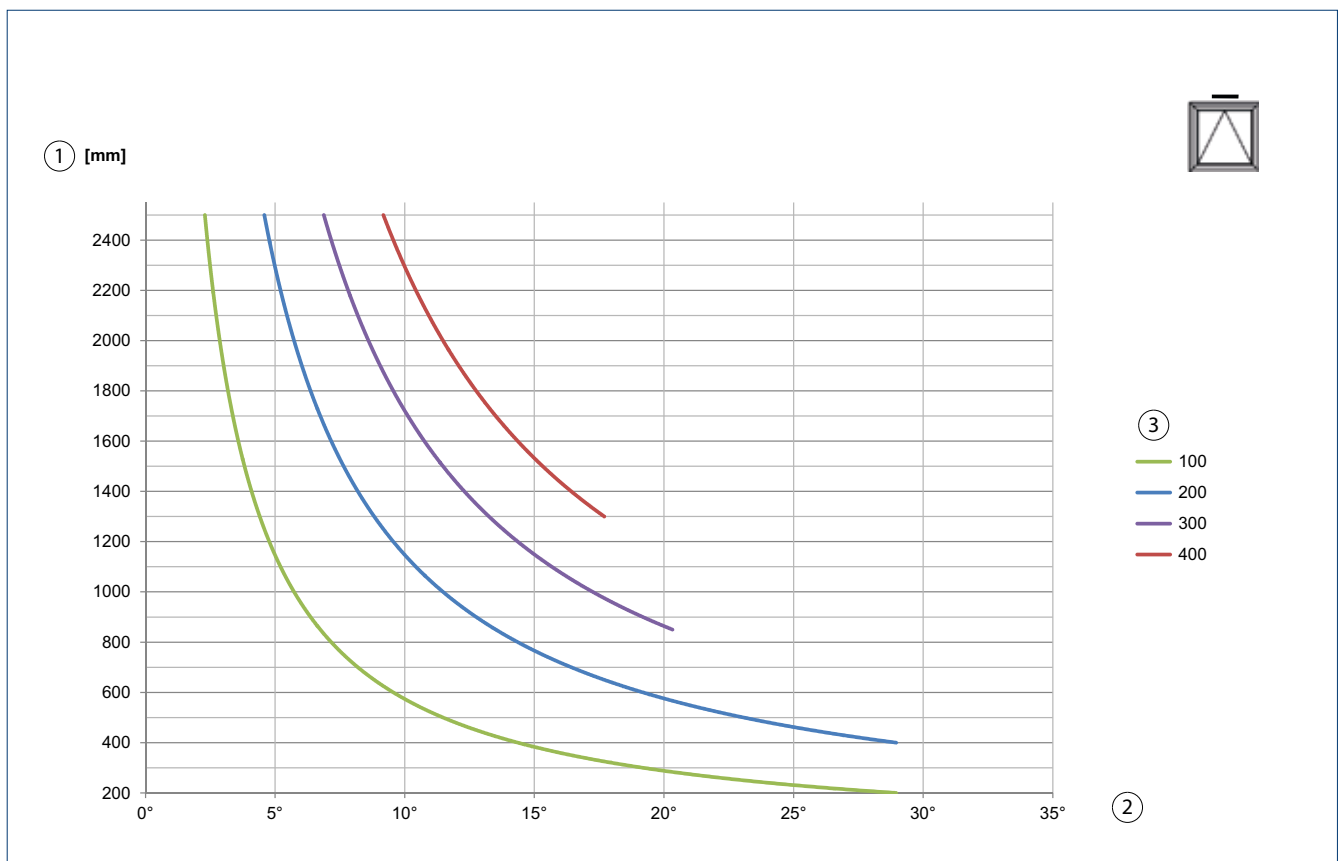

1 = Secondary closing edge | 2 = Opening angle | 3 = Stroke

AREA OF APPLICATION BOTTOM-HUNG WINDOW LEAF INSTALLATION INWARD OPENING

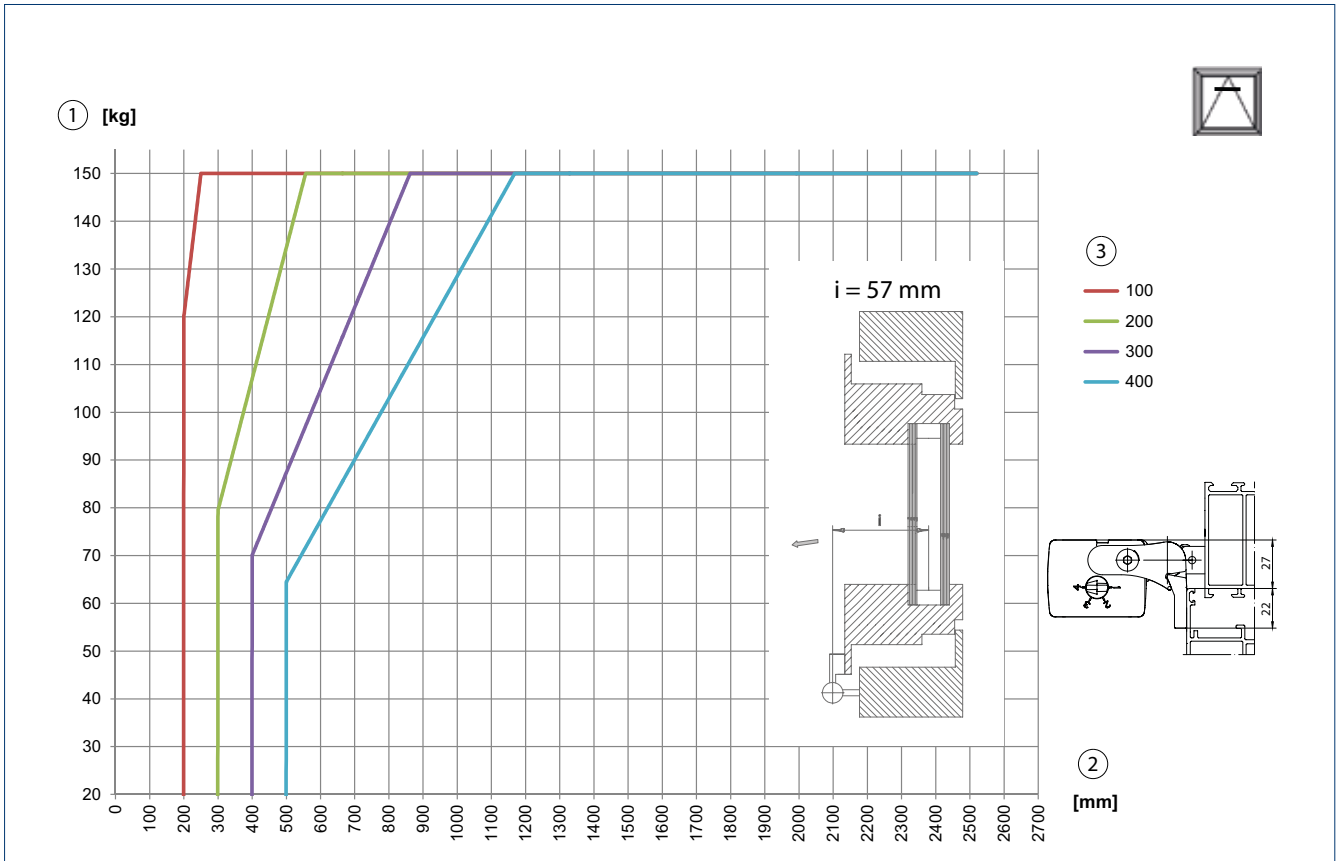

1 = Leaf weight | 2 = Secondary closing edge | 3 = Stroke

OPENING ANGLE BOTTOM-HUNG WINDOW LEAF INSTALLATION INWARD OPENING

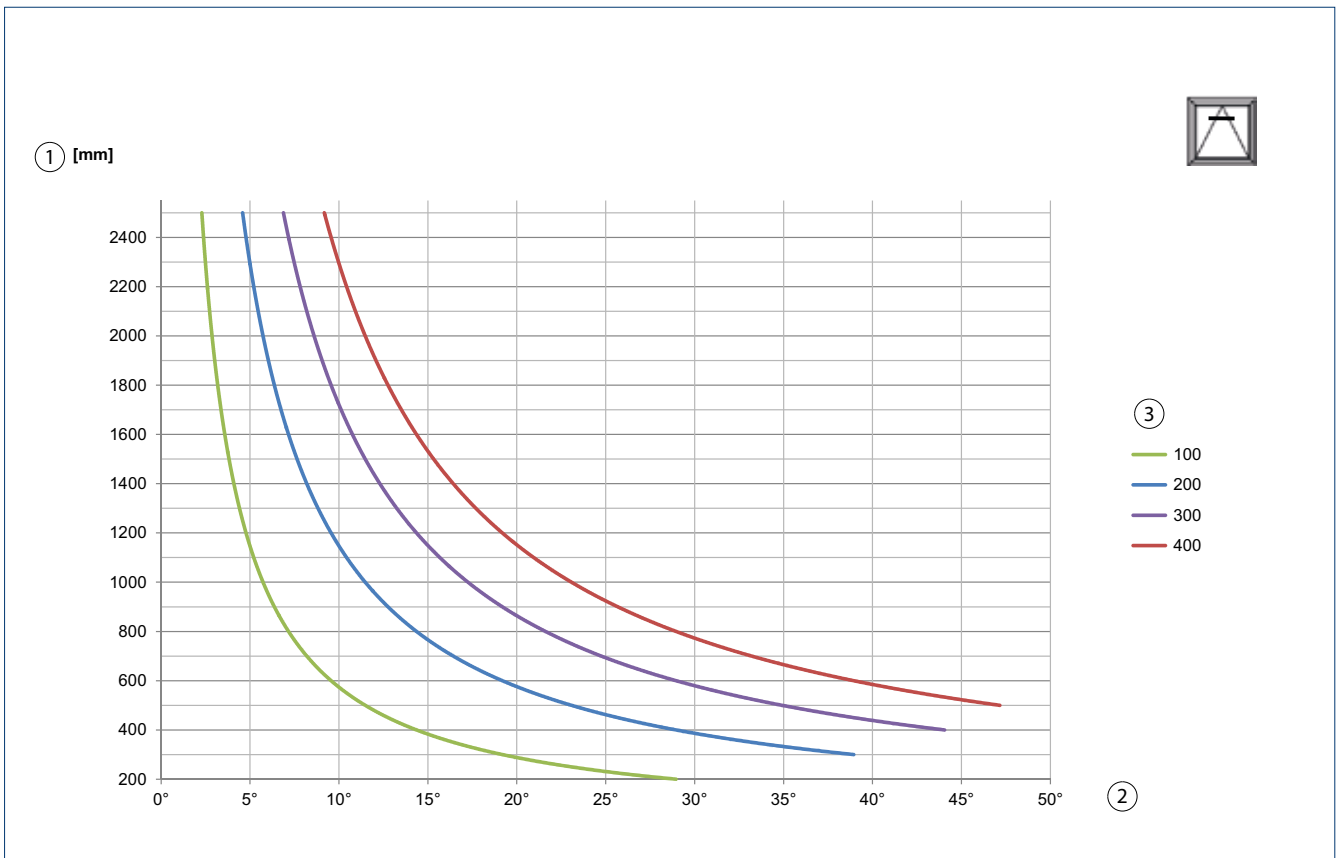

1 = Secondary closing edge | 2 = Opening angle | 3 = Stroke

**AREA OF APPLICATION BOTTOM-HUNG WINDOW FRAME INSTALLATION INWARD OPENING (WITH SWIVEL BRACKET)**

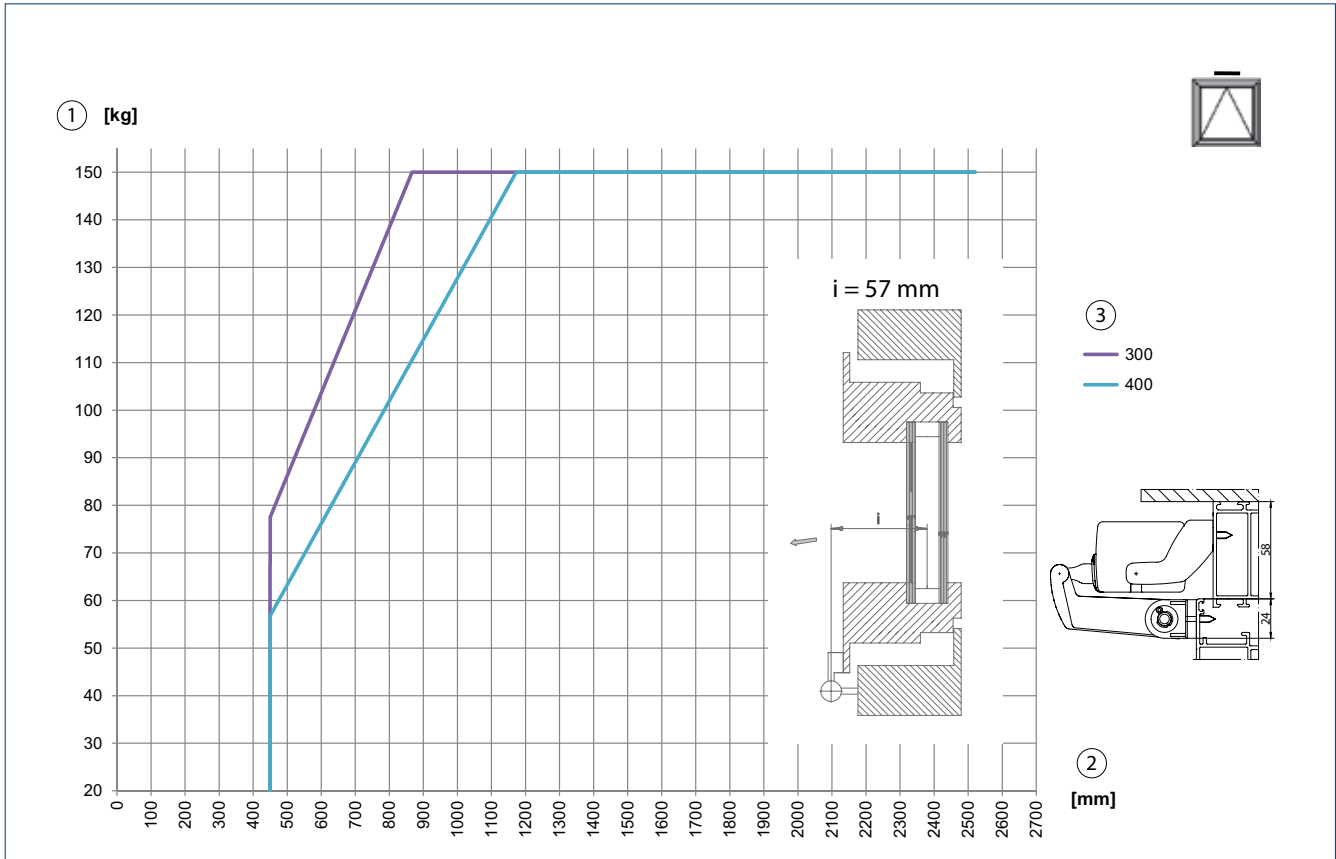

1 = Leaf weight | 2 = Secondary closing edge | 3 = Stroke

**OPENING ANGLE BOTTOM-HUNG WINDOW FRAME INSTALLATION INWARD OPENING (WITH SWIVEL BRACKET)**

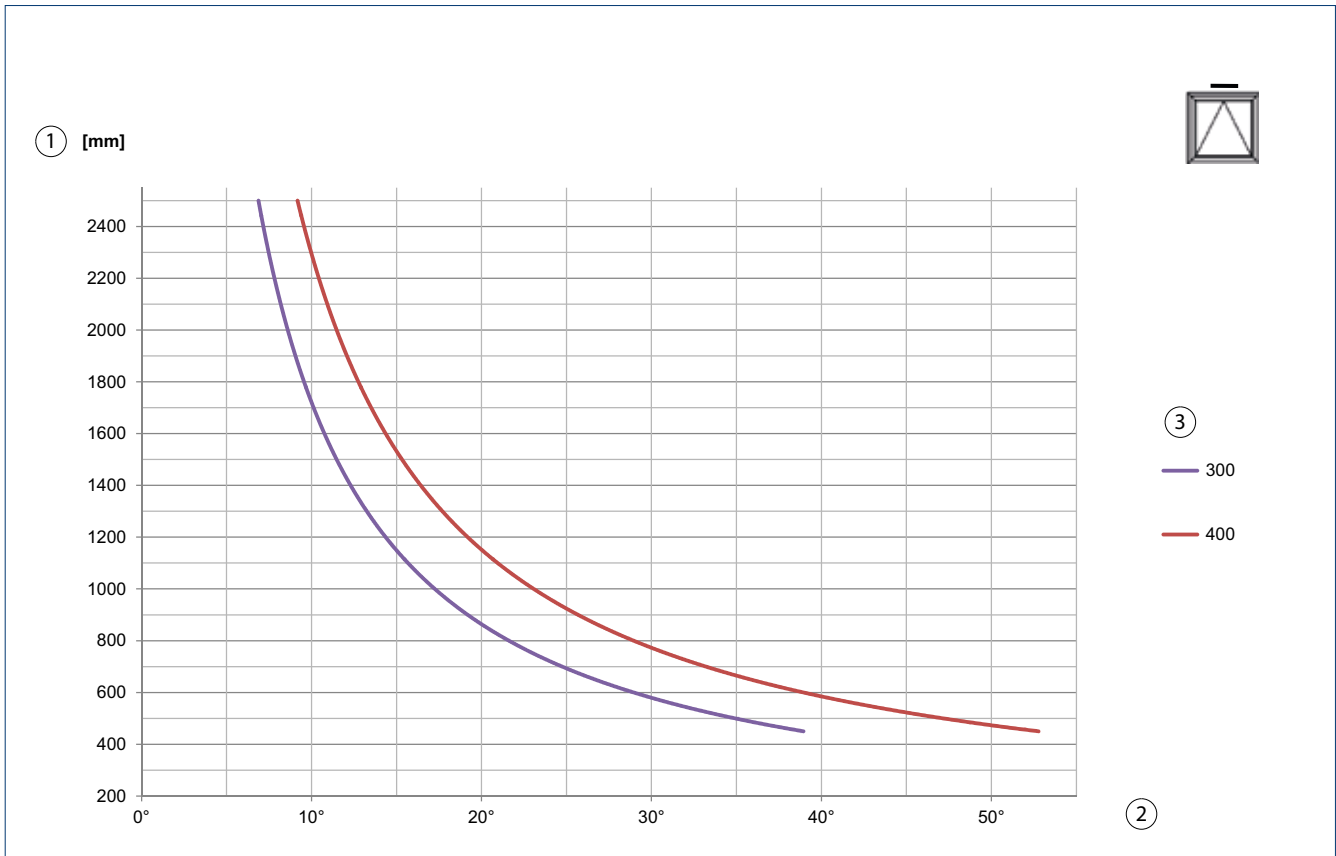

1 = Secondary closing edge | 2 = Opening angle | 3 = Stroke



AREA OF APPLICATION TOP-HUNG WINDOW FRAME INSTALLATION OUTWARD OPENING

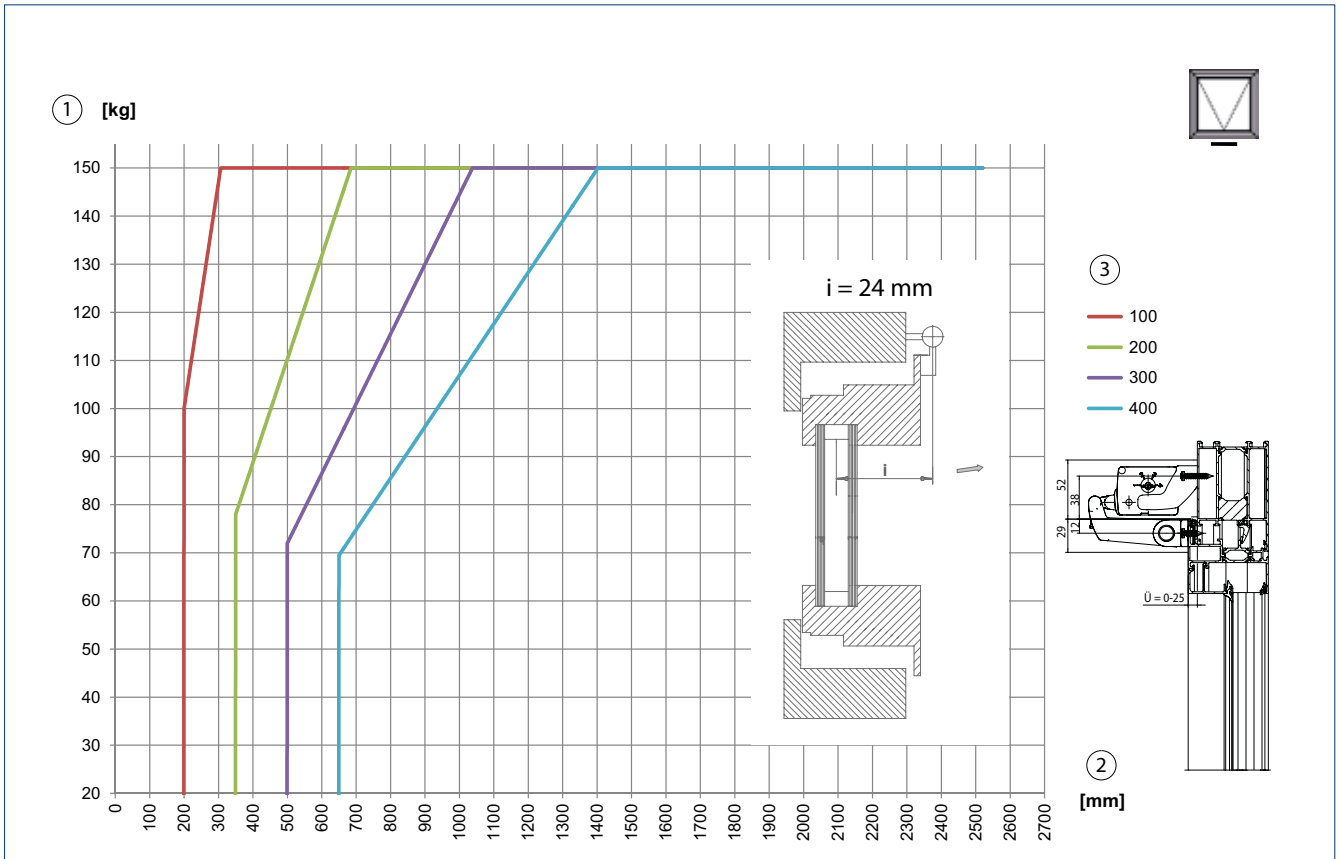

1 = Leaf weight | 2 = Secondary closing edge | 3 = Stroke

OPENING ANGLE TOP-HUNG WINDOW FRAME INSTALLATION OUTWARD OPENING

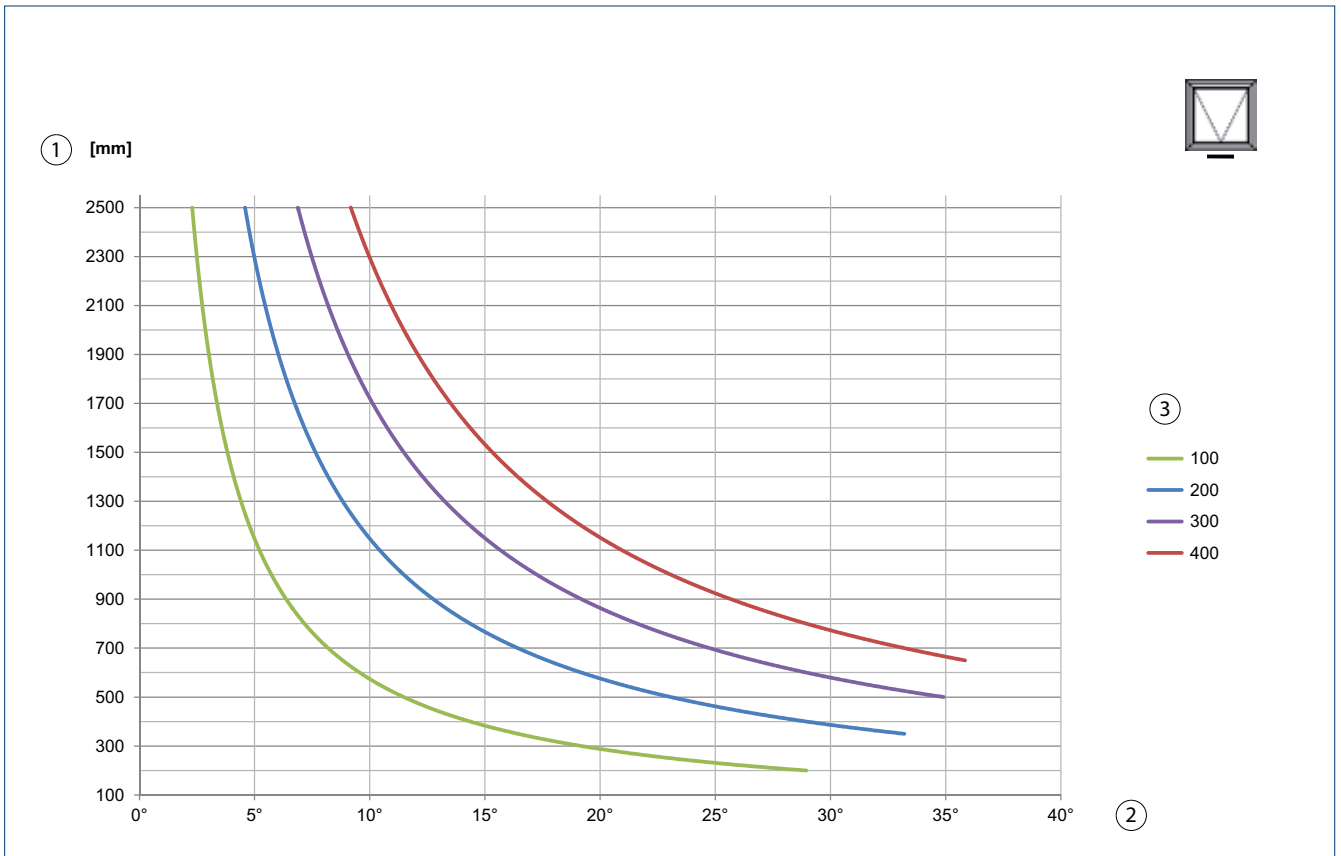

1 = Secondary closing edge | 2 = Opening angle | 3 = Stroke

SPACE NEEDED

SPACE NEEDED FOR FRAME INSTALLATION INWARD OPENING

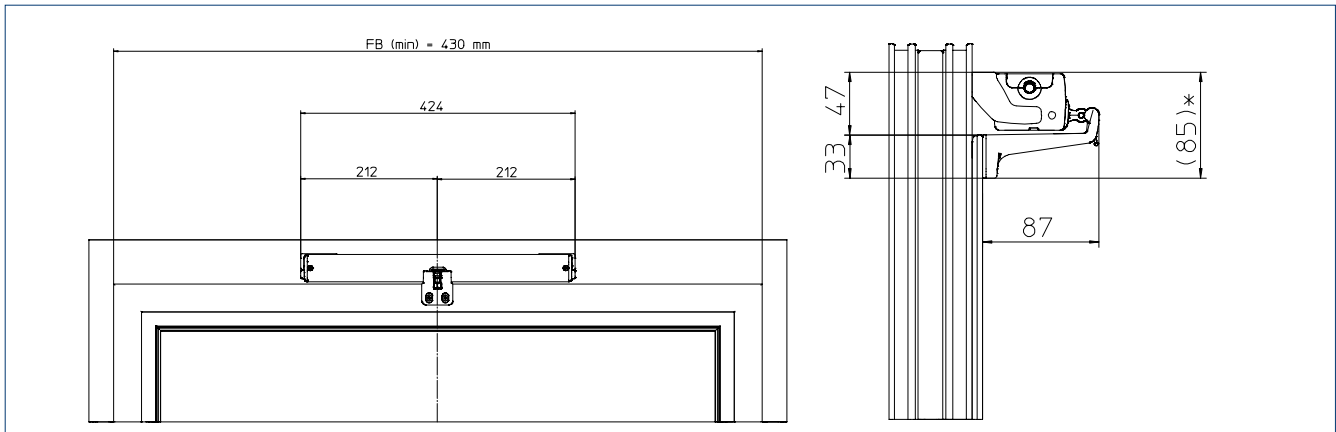

FB = Leaf width

SPACE NEEDED FOR FRAME INSTALLATION INWARD OPENING, SYNCRO 2

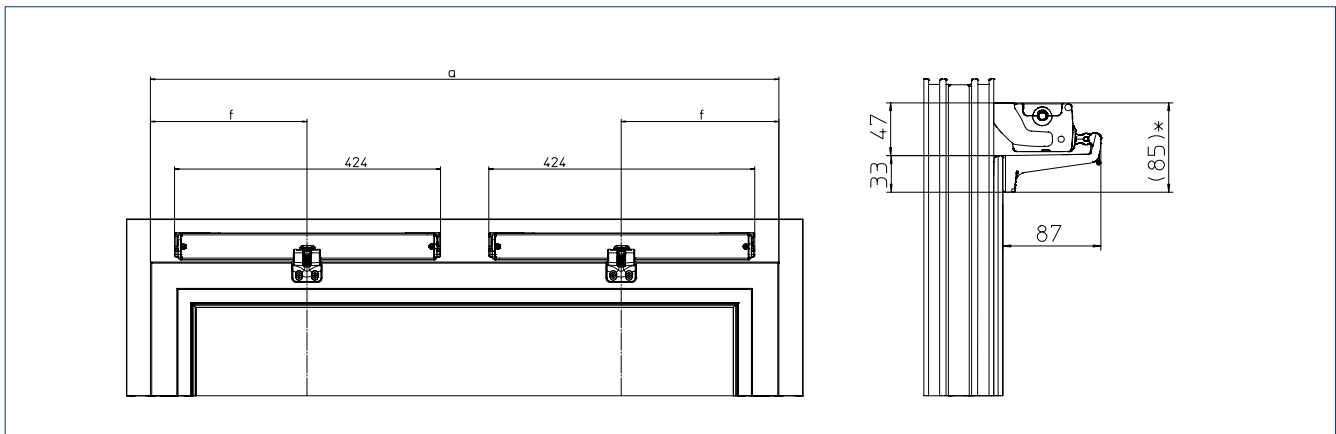

SPACE NEEDED FOR FRAME INSTALLATION INWARD OPENING, INWARD OPENING SYNCRO 3

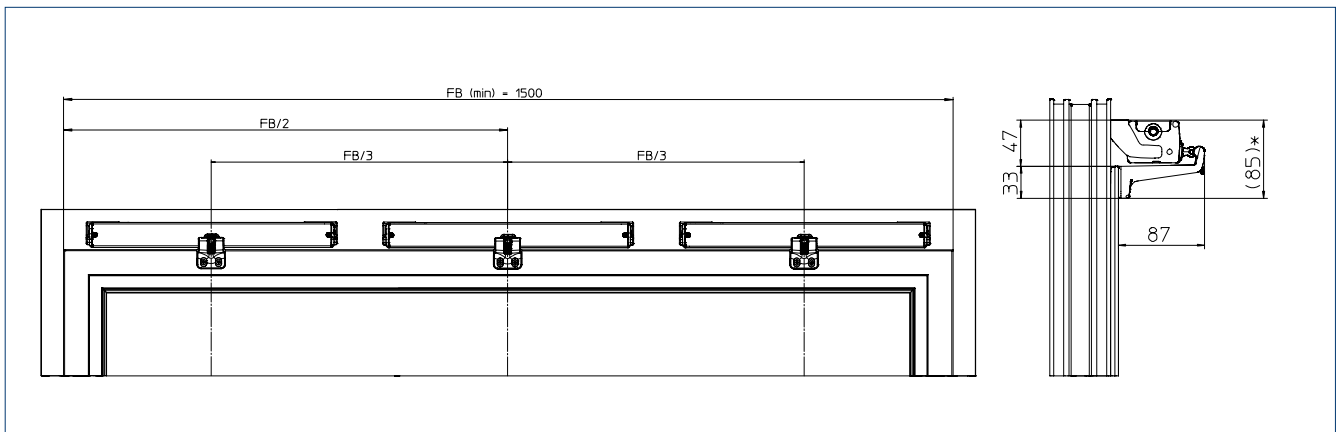

FB = Leaf width

## SPACE NEEDED

### SPACE NEEDED FOR LEAF INSTALLATION INWARD OPENING

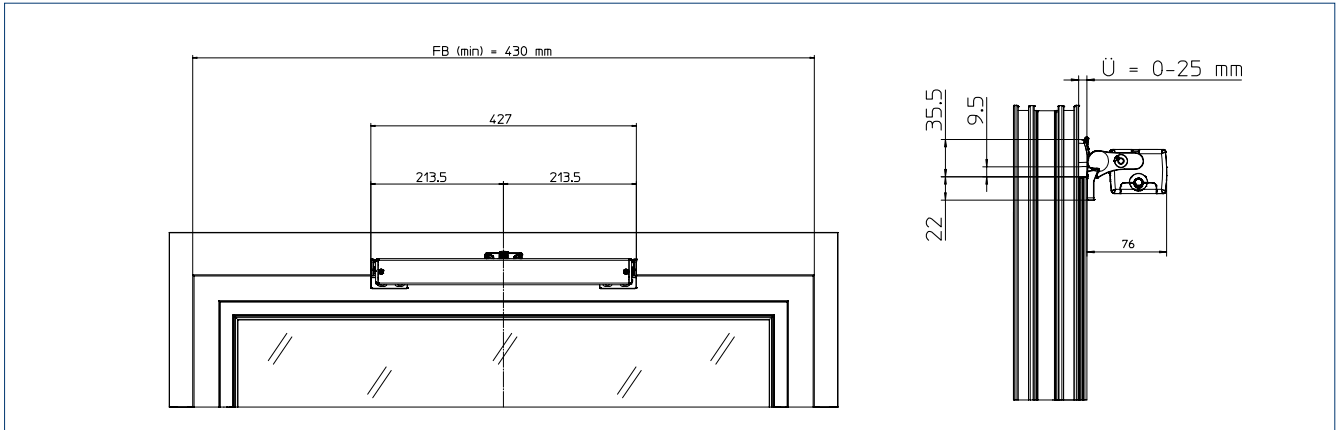

FB = Leaf width | Ü = Overlap range

### SPACE NEEDED FOR FRAME INSTALLATION OUTWARD OPENING

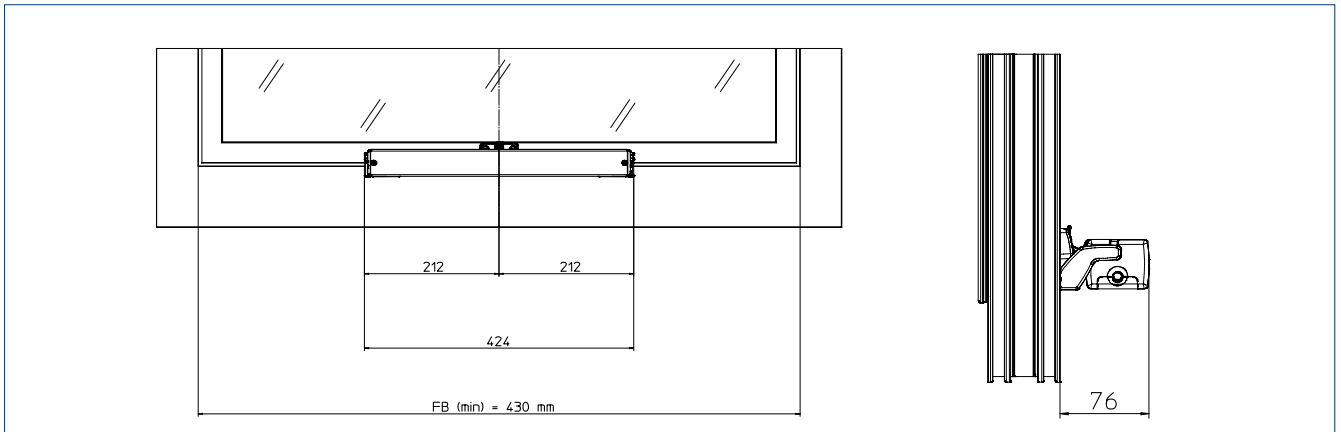

FB = Leaf width

### SWIVEL BRACKET

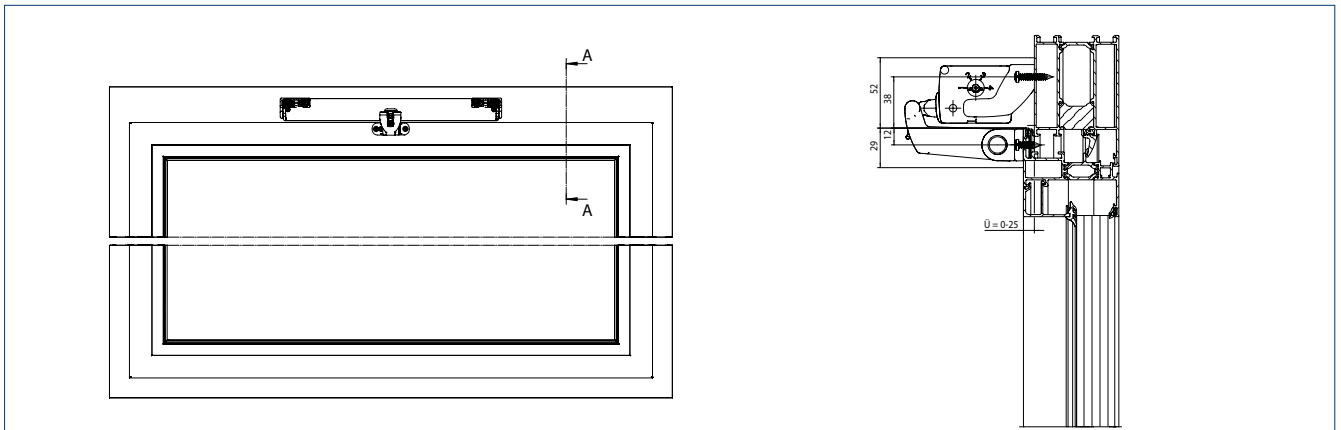

FB = Leaf width

## ORDER INFORMATION

Designation	Version	ID no.
GEZE E 740 Stroke adjustable 100/200/300/400 mm	EV1 white RAL 9016 according to RAL	112340 112341 112342
GEZE E 740 SYNCRO Stroke adjustable 100/200/300/400 mm	EV1 white RAL 9016 according to RAL	112400 112401 112402
GEZE E 740 DUAL Stroke 100/200/300/400 mm adjustable, length 1000 mm	EV1 white RAL 9016	135575 135576
GEZE E 740 DUAL Stroke 100/200/300/400 mm adjustable, length 1600 mm	EV1 white RAL 9016	135577 135578
<b>ACCESSORIES</b>		
Drive bracket roof window for E 740 for installation of the E 740 on roof windows and skylight domes		112360
Drive bracket roof window for E 740 suitable for E 740 DUAL		135758
Console AW E 740 RM/FM for frame and leaf installation on outward opening top-hung windows as well as on roof windows and skylight domes		112365
Console EW E 740 RM for frame installation on inward opening bottom-, top- and side-hung windows		112355
Console set EW E 740 FM for leaf installation on inward opening bottom-hung and top-hung windows		125398
Swivel bracket EW E 740 RM for frame installation on inward opening bottom-hung windows		122106
Console AW E 740 RM/FM Mini for frame and leaf installation on outward opening top-hung windows as well as on roof windows and skylight domes		133269

# Fixtures and consoles



Drive bracket roof window for E 740 (112360)



Drive bracket roof window for E 740 DUAL (135758)



Console AW E 740 RM/FM (112365)



Console EW E 740 RM (112355)



Console set EW E 740 FM (125398)



Swivel bracket EW E 740 RM (122106)



Console AW E 740 RM/FM Mini (133269)

# Slimchain



Chain drive in an attractive design with numerous possible applications in 24 V version

## AREAS OF APPLICATION

- Smoke and heat extraction system and natural ventilation (24 V) in the façade area
- Can be used in the exhaust air and air intake
- Inward and outward opening windows with bottom-, top- and side-hung leaves
- Projected top hung and parallel opening window
- Installation on wooden, PVC or metal windows
- Leaf, frame or integrated installation
- Synchronisation of up to four drives
- System solution in combination with the Power lock locking drive

## PRODUCT FEATURES

- Slim and discreet appearance integrates perfectly into the façade design
- Continuously adjustable drive stroke and individual speeds for ventilation and smoke and heat extraction mode
- Available as special version - stroke, cable length, colour and alignment configurable to DIN left/right
- Synchronisation of max. four drives without external control unit
- DIP switches for changing over the mode of operation (Solo and Syncro, master, slave)
- Fast and easy installation with the GEZE Smart fix installation system
- IQ windowdrive - intelligent drive control
- SHEV tested according to EN 12101-2

**TECHNICAL DATA**
**Slimchain**
**GENERAL INFORMATION**

Length	stroke 300: 560 mm, stroke 500: 660 mm, stroke 800: 810 mm (each with consoles)
Height	25 mm
Depth	44 mm
Space needed on frame (min.)	frame installation inward opening: 40 mm, leaf installation inward opening: 16/21 mm, frame installation outward opening: 31 mm
Space needed on leaf (min.)	frame installation inward opening: 40 mm, leaf installation inward opening: 34/29 mm, Frame installation outward opening: 19 mm

**SPECIFICATIONS**

Possible stroke lengths	300 mm, 500 mm, 800 mm
Factory presetting	ventilation stroke 300 mm (slow speed), alarm stroke full opening width (fast speed)
Opening speed smoke and heat extraction	15 mm/s
Opening speed ventilation	5 mm/s
Closing speed	5 mm/s
Tensile force (max.)	300 N
Compressive force (max.)	200 N (depending on stroke), see force-path chart
Holding force (max.)	2000 N
Leaf weight (max.) <sup>1)</sup>	200 kg
Overlap range <sup>2)</sup>	0 – 23 mm

**ELECTRICAL DATA**

Operating voltage	24 V ± 25 %
Current consumption	ventilation (24 V): 0.9 A; smoke and heat extraction (18 V): 1.1 A
Power consumption (max.)	20 W
Duty rating	30 %
Length of power supply cable	2 m
Special length of power supply cable	5 m, 7.5 m
Cable dimensions	4 x 0.75 mm <sup>2</sup>
Temperature range	-5 – 70 °C
IP rating / protection rating	IP40 / III

**FUNCTIONS**

Stroke length settable	●
Syncro function	●
Opening speed settable (ventilation)	●
Additional locking device available	●
Type of additional locking (max.)	2 locking drives
Type of stroke shortening	synchronising unit, factory setting
End position cut-off extended	electronically via internal path sensor
End position cut-off retracted	electric, electronic via current consumption
Overload cut-off	●
Complete opening within 60 s	yes, including locking drive
SHEV tested according to EN 12101-2	●
Synchronisation (max.)	4 drives

**TYPES OF INSTALLATION**

Bottom-hung window	inward opening outward opening	frame / leaf frame
Side-hung window	inward opening outward opening	frame / leaf frame
Top-hung window	inward opening outward opening	frame / leaf frame
Projected top hung window	outward opening	frame
Parallel opening window	outward opening	frame

● = YES | 1 = The total weight is limited by the hinges and depends on the details provided by the profile system manufacturer. | 2 = Depending on the application and the console set

**PRODUCT SCALE DRAWING**

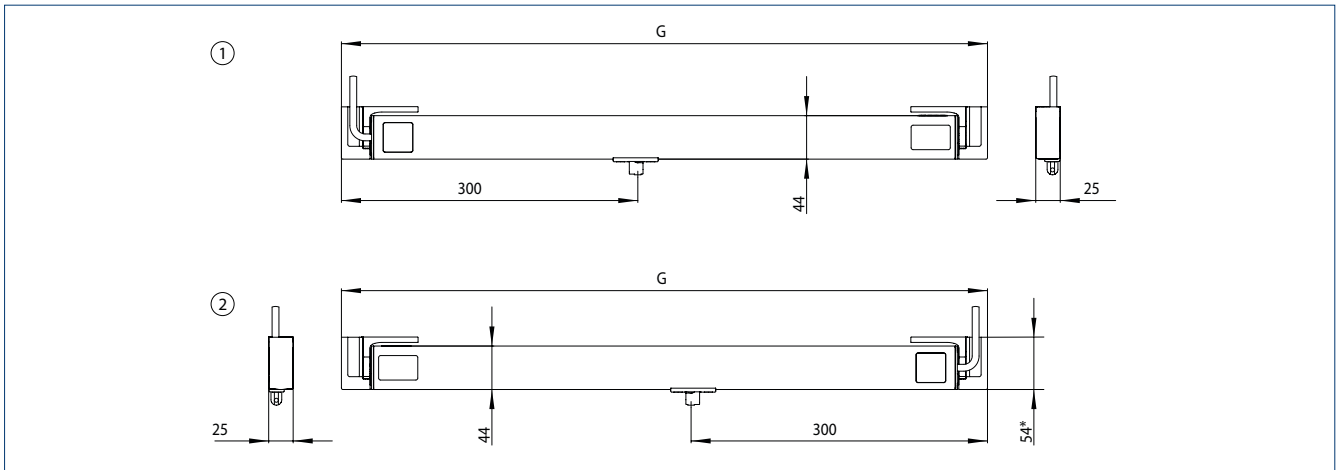

G = Length | 1 = GEZE Slimchain L | 2 = GEZE Slimchain R | \* = Console set A

**TYPES OF INSTALLATION**

**Frame installation  
INWARD opening**

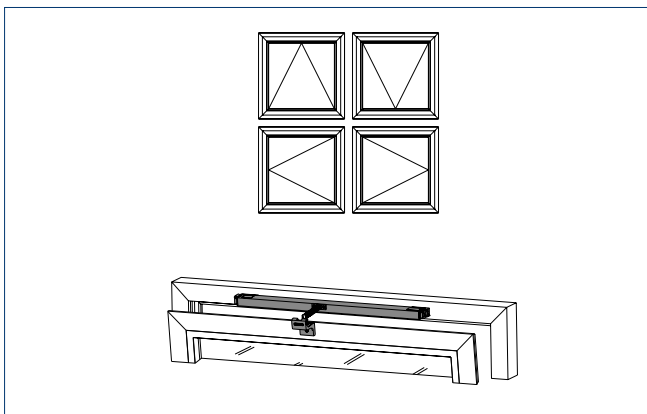

Console set A

**Leaf installation  
INWARD opening**

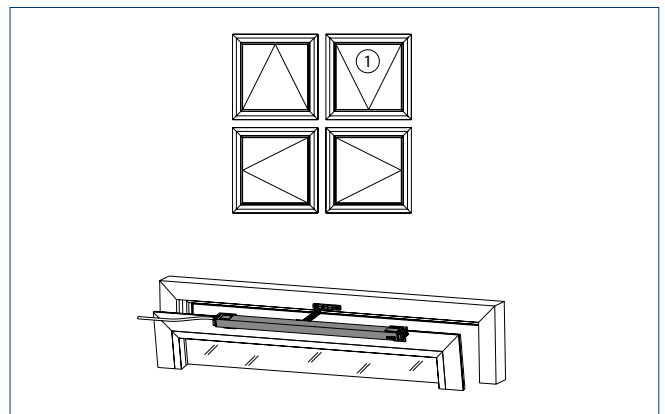

Console set B | 1 = on request

**Frame installation  
OUTWARD opening**

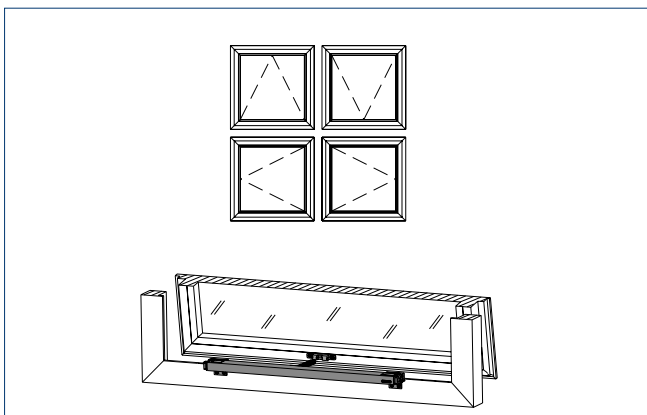

Console set B

**Frame installation  
OUTWARD opening  
Projected top hung window / parallel opening window**

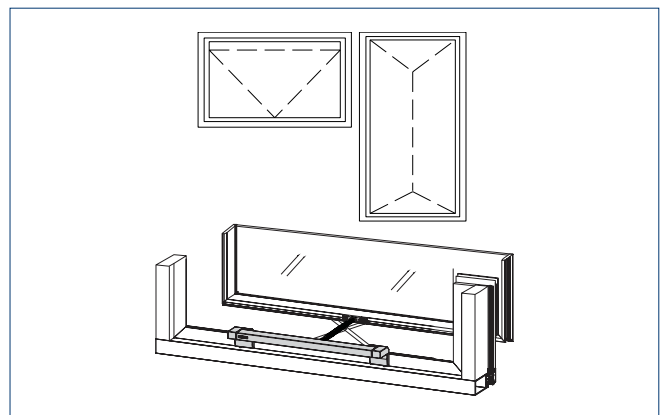

Console set P

FORCE-PATH CHART

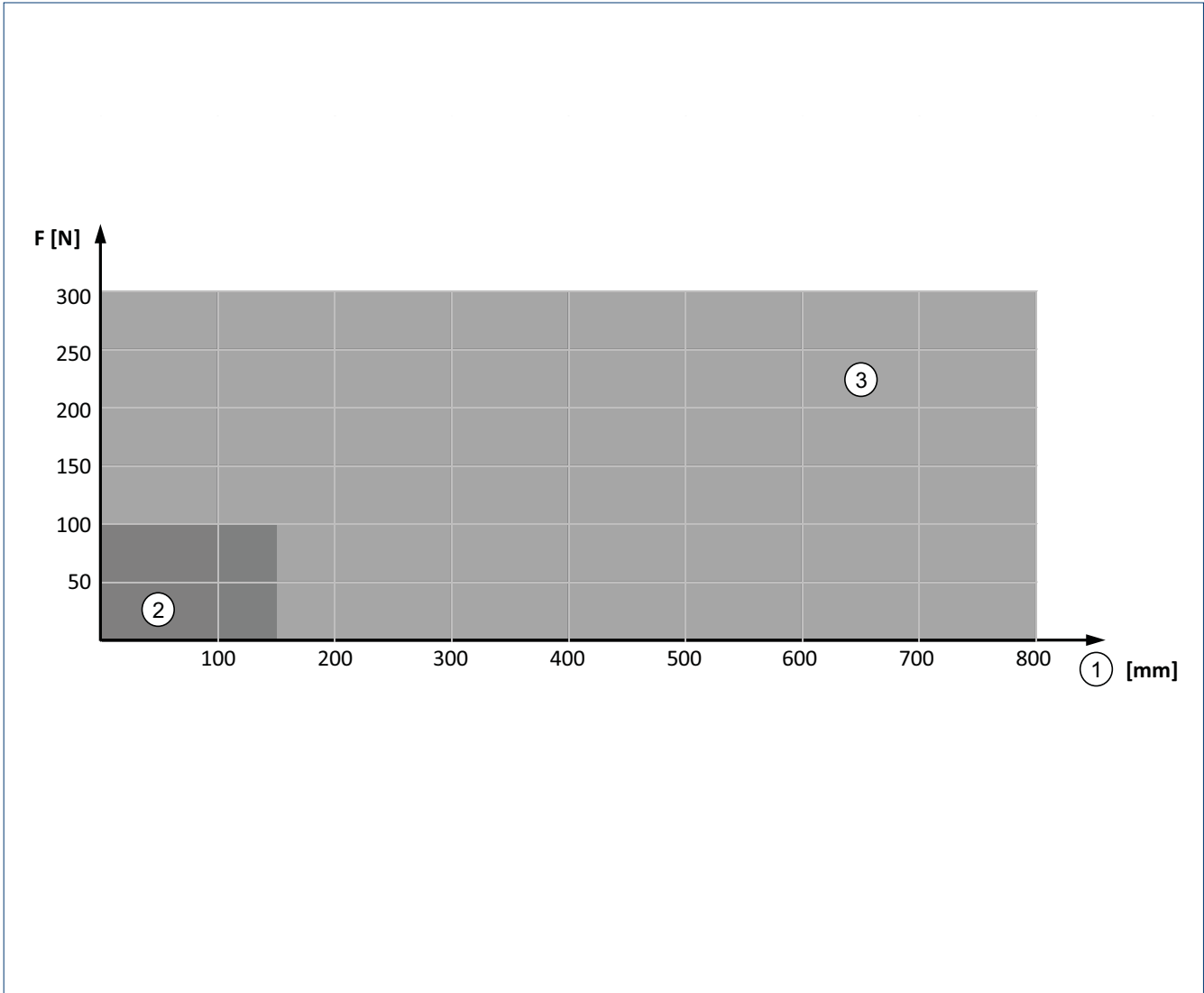

F = Force | 1 = Stroke | 2 = Pressure | 3 = Tension



**AREA OF APPLICATION BOTTOM-HUNG WINDOW FRAME INSTALLATION INWARD OPENING (DRIVE CAN BE SWIVELLED) / BOTTOM-HUNG WINDOW FRAME INSTALLATION OUTWARD OPENING (DRIVE CAN BE SWIVELLED)**

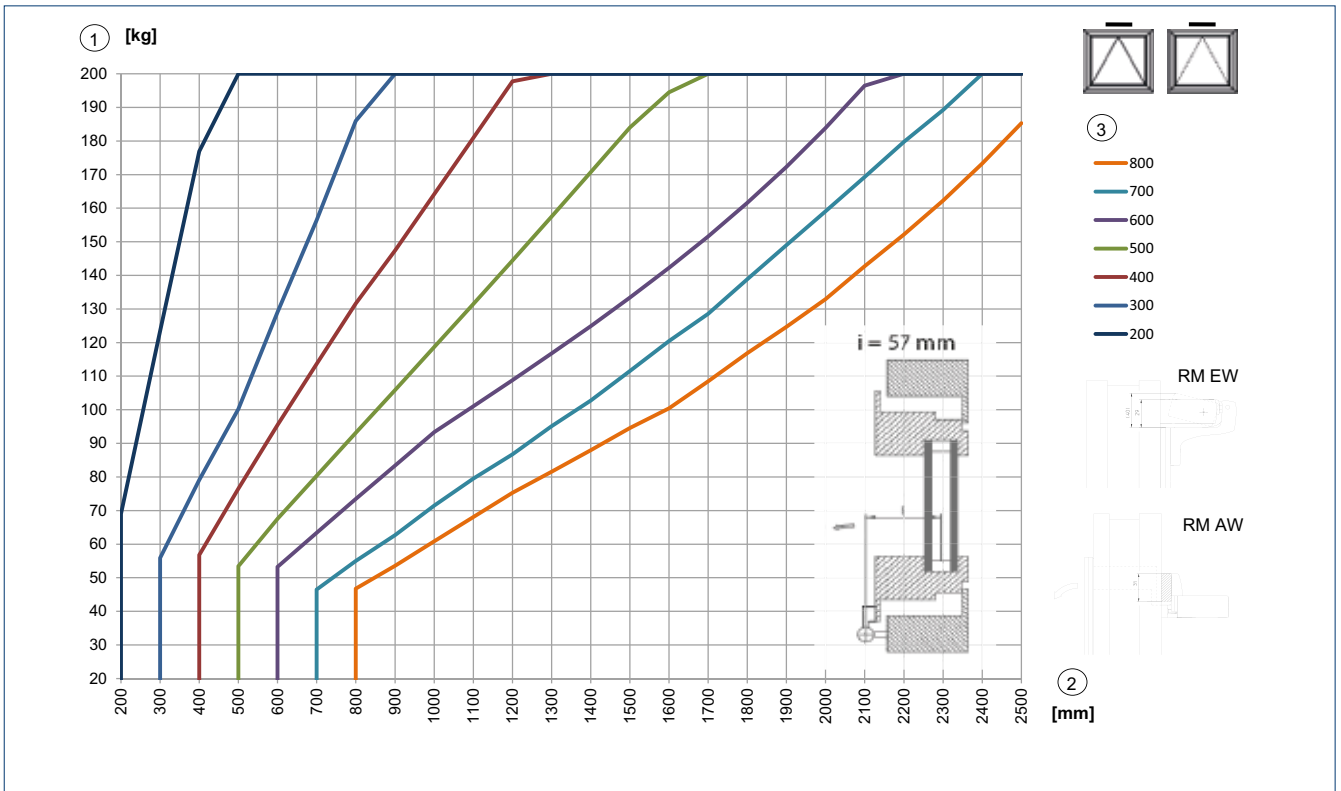

Area of application applies for one Solo drive, for Syncro 2 or Syncro 3 the leaf weight can be doubled or tripled.  
The details provided by the profile system manufacturer must be heeded. 1 = Leaf weight | 2 = Secondary closing edge | 3 = Stroke [mm] | RM EW = Frame installation INWARD opening | RM AW = Frame installation OUTWARD opening

**AREA OF APPLICATION BOTTOM-HUNG WINDOW LEAF INSTALLATION INWARD OPENING (DRIVE CANNOT BE SWIVELLED) AND FOR INTEGRATED INSTALLATION**

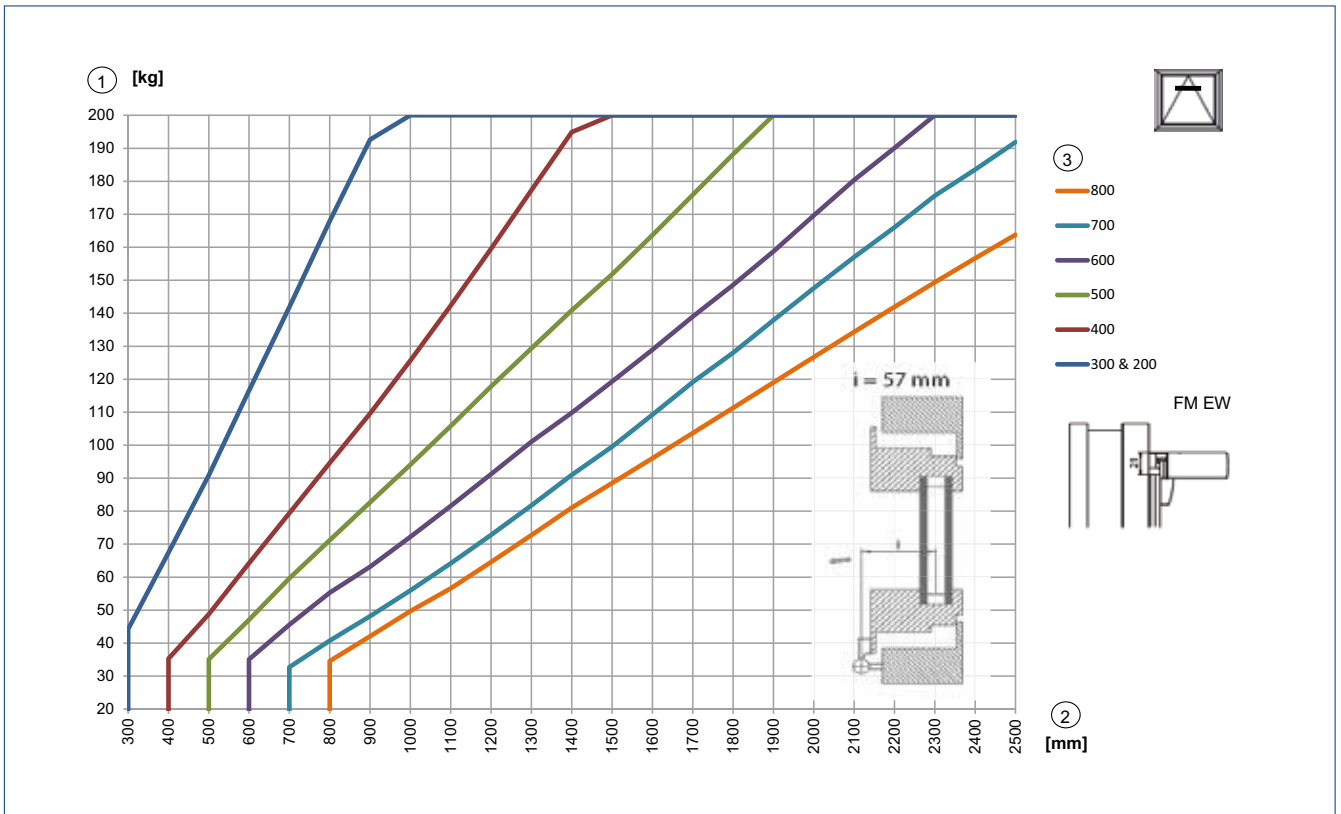

Area of application applies for one Solo drive, for Syncro 2 or Syncro 3 the leaf weight can be doubled or tripled.  
The details provided by the profile system manufacturer must be heeded.  
1 = Leaf weight | 2 = Secondary closing edge | 3 = Stroke [mm]

**MINIMUM LEAF WIDTH SIDE-HUNG WINDOW FRAME INSTALLATION INWARD OPENING / SIDE-HUNG WINDOW FRAME INSTALLATION OUTWARD OPENING (DRIVE CANNOT BE SWIVELLED)**

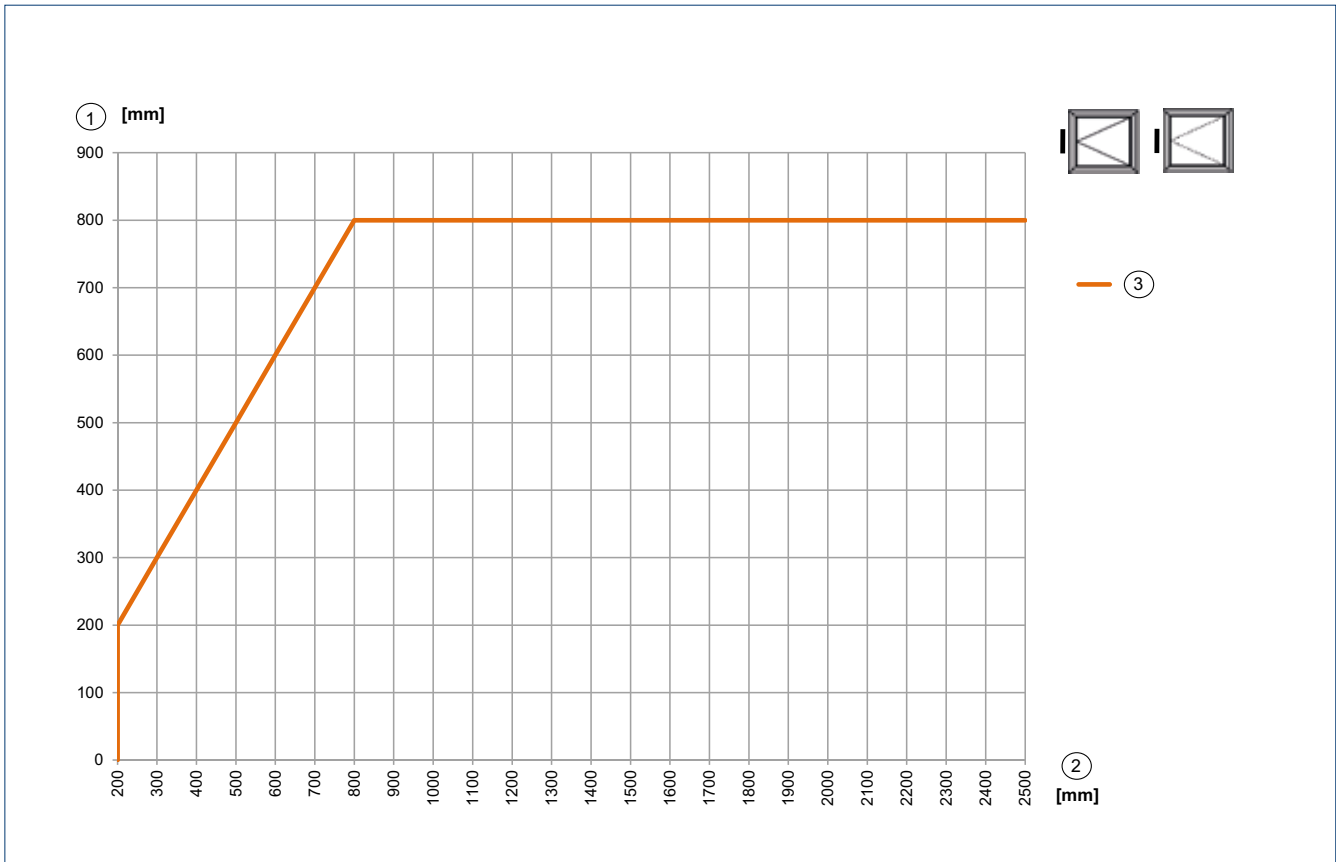

1 = Stroke | 2 = Secondary closing edge | 3 = Alarm and ventilation

**MINIMUM LEAF WIDTH SIDE-HUNG WINDOW LEAF INSTALLATION INWARD OPENING (DRIVE CANNOT BE SWIVELLED) AND FOR INTEGRATED INSTALLATION**

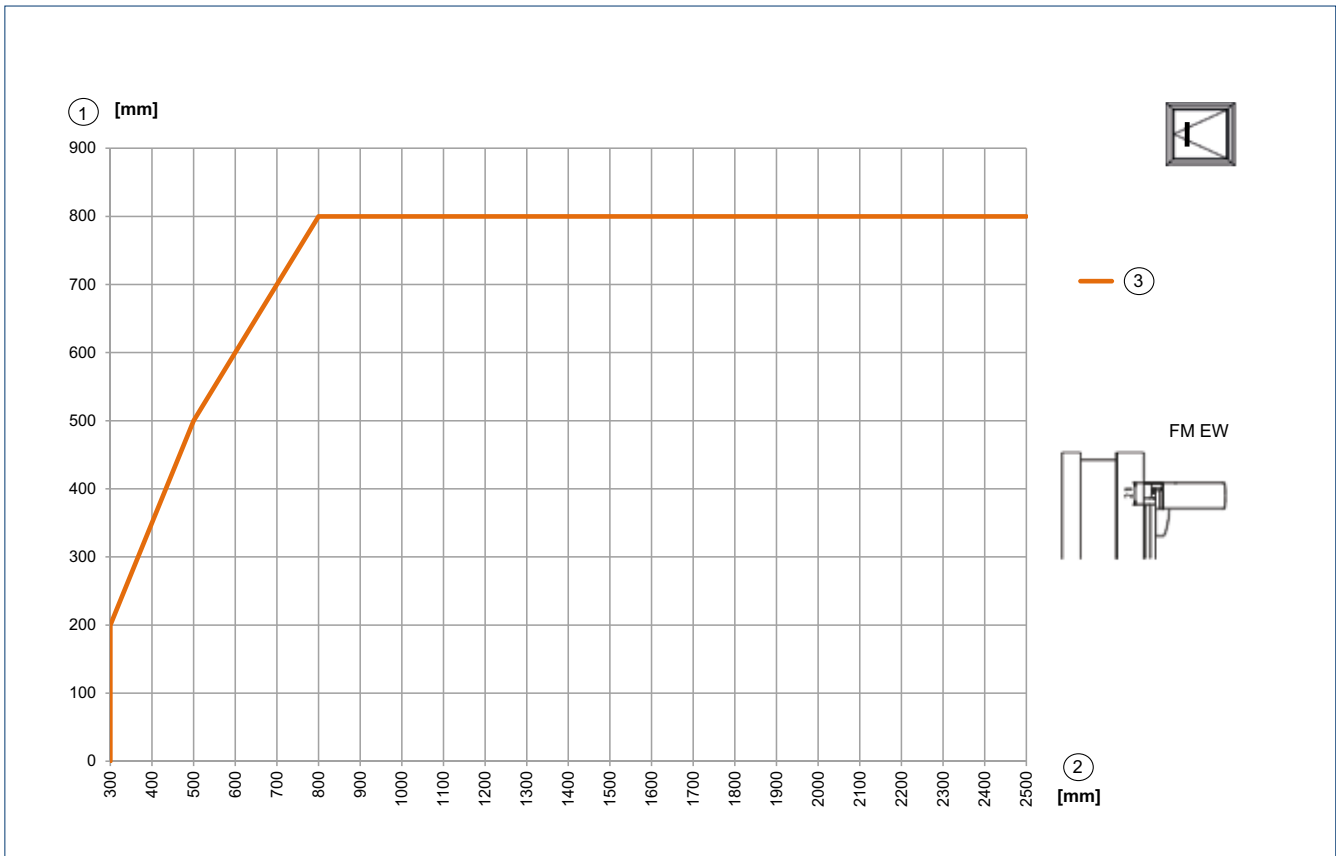

1 = Stroke | 2 = Secondary closing edge | 3 = Alarm and ventilation

**AREA OF APPLICATION TOP-HUNG WINDOW FRAME INSTALLATION OUTWARD OPENING (DRIVE CAN BE SWIVELLED)**

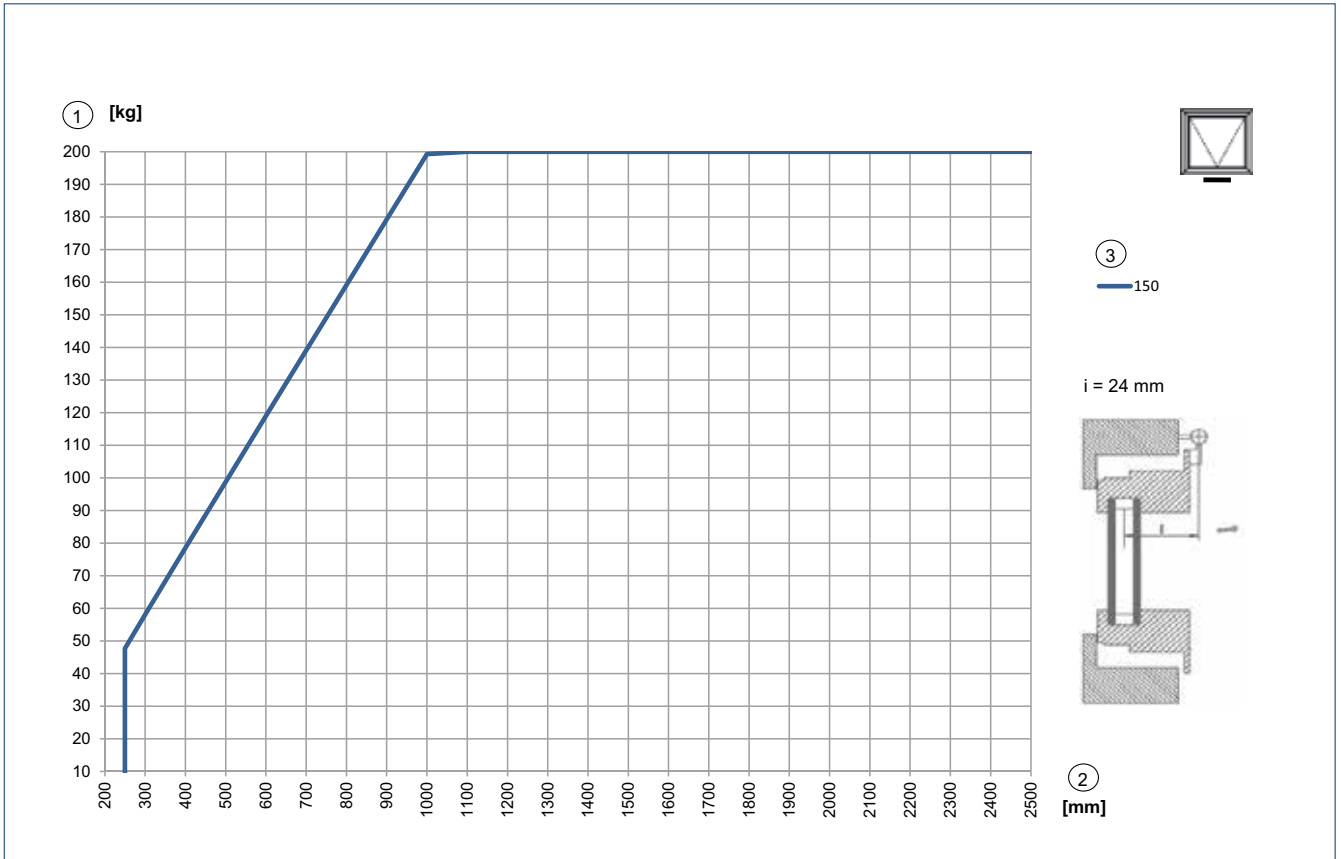

Area of application applies for one Solo drive, for Syncro 2 or Syncro 3 the leaf weight can be doubled or tripled.  
 The details provided by the profile system manufacturer must be heeded.  
 1 = Leaf weight | 2 = Secondary closing edge | 3 = Stroke [mm]

**AREA OF APPLICATION TOP-HUNG WINDOW FRAME INSTALLATION INWARD OPENING (DRIVE CAN BE SWIVELLED) / TOP-HUNG WINDOW LEAF INSTALLATION INWARD OPENING (DRIVE CANNOT BE SWIVELLED) AND FOR INTEGRATED INSTALLATION**

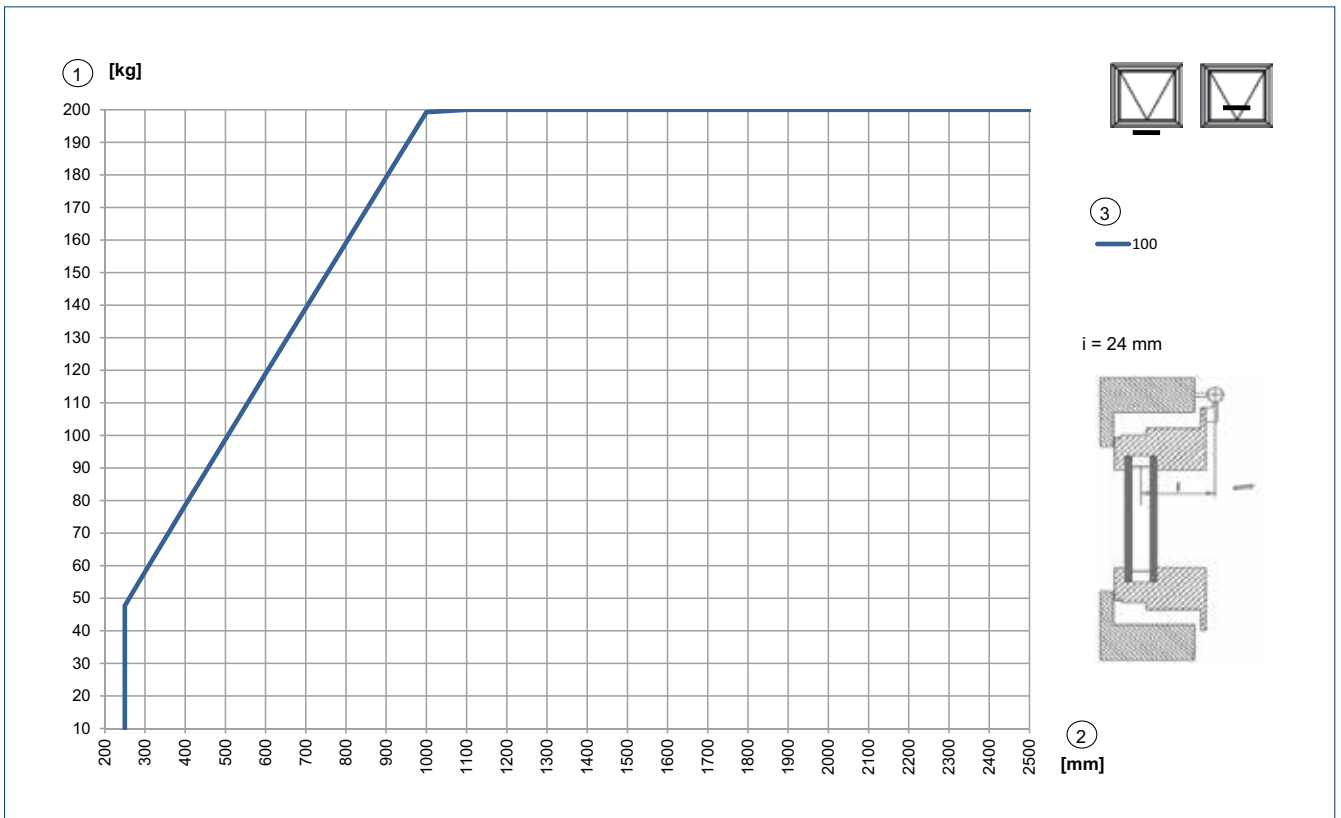

1 = Leaf weight | 2 = Secondary closing edge | 3 = Stroke [mm]

### SPACE NEEDED

Stroke	E [mm]	G [mm]	S [mm]
300	260	560	600
500	360	660	720
800	510	810	1020

→ **Note:** Illustrations with cable side left, cable side right is reversed.

### SPACE NEEDED FOR FRAME INSTALLATION INWARD OPENING

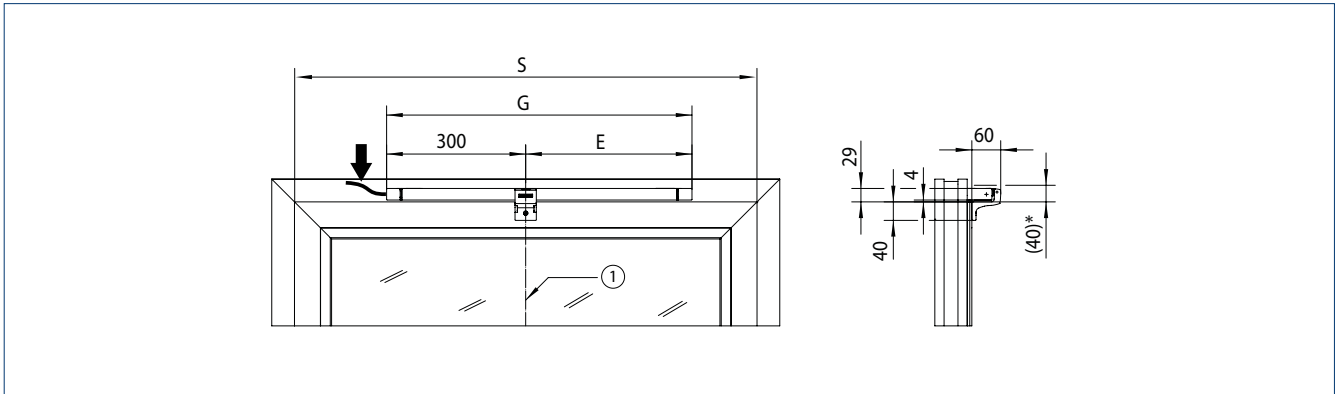

See table for dimensions for E, G and S  
1 = Centre of window | \* = Swivelling range

### SPACE NEEDED FOR LEAF INSTALLATION INWARD OPENING

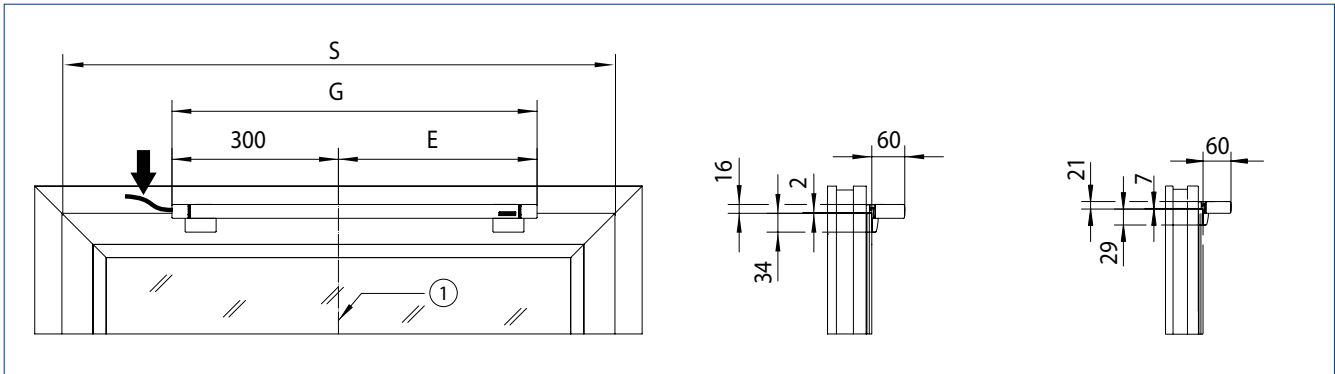

Dimensions for E, G and S see table | 1 = Centre of window

### SPACE NEEDED FOR FRAME INSTALLATION OUTWARD OPENING

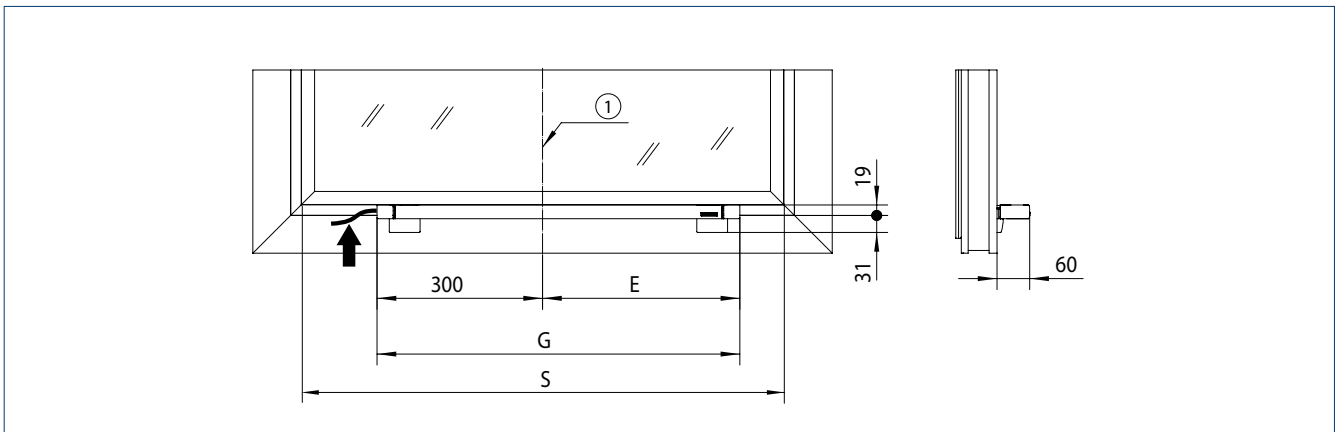

Dimensions for E, G and S see table | 1 = Centre of window

## SPACE NEEDED – SYNCRO 2

→ **Note:** The illustrations apply for all installation possibilities.

### SPACE NEEDED FOR INSTALLATION WITH ONE LEFT-HAND AND ONE RIGHT-HAND DRIVE

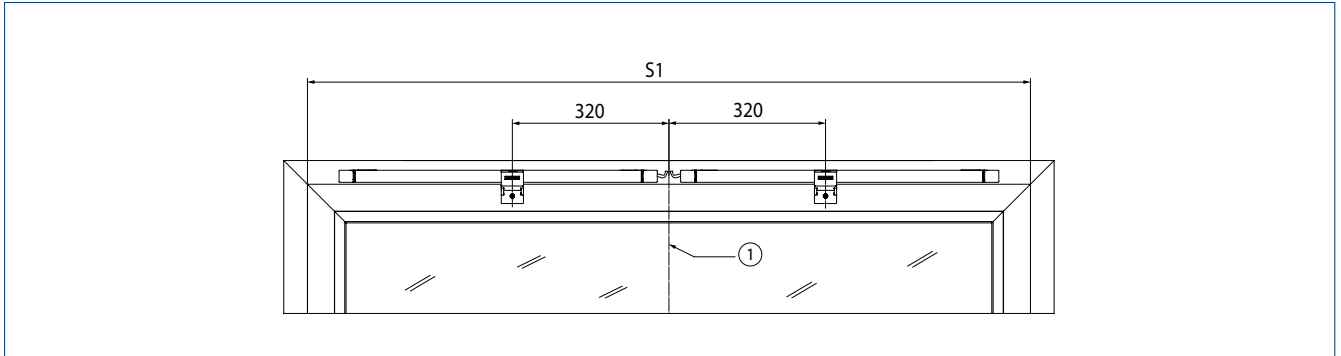

→ **Note:** Not suitable for side-hung windows.  
Dimensions for S1 see table I 1 = Centre of window

Stroke	S1 [mm] min.	ID no. EV1/white RAL 9016	Number
300	1160	147030/147031 R 147035/147036 L	1 1
500	1360	147040/147041 R 147045/147046 L	1 1
800	1660	147050/147051 R 147055/147056 L	1 1

### SPACE NEEDED FOR INSTALLATION WITH TWO RIGHT-HAND DRIVES (REVERSED FOR TWO LEFT-HAND DRIVES)

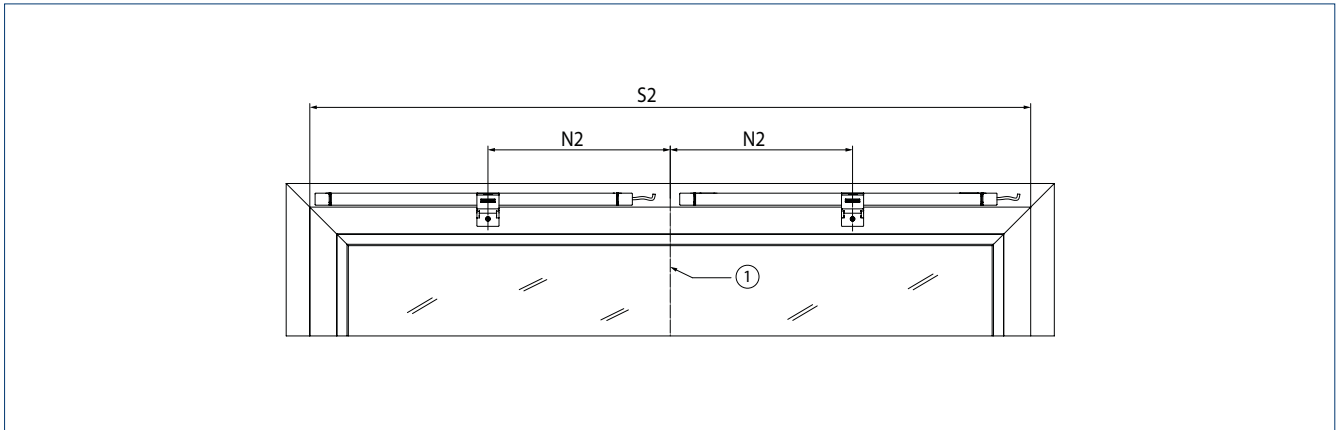

→ **Note:** Suitable for side-hung windows.  
Dimensions for S2 and N2 see table I 1 = Centre of window

Stroke	N2 [mm]	S2 [mm] min.	ID no. EV1/ white RAL 901	S2 [mm] min.	ID no. EV1/ white RAL 901	S2 [mm] min.
300	300	1200	147030/147031 R 147035/147036 L	2 –	147030/147031 R 147035/147036 L	– 2
500	350	1420	147040/147041 R 147045/147046 L	2 –	147040/147041 R 147045/147046 L	– 2
800	425	1870	147050/147051 R 147055/147056 L	2 –	147050/147051 R 147055/147056 L	– 2

**SPACE NEEDED - SYNCRO 3**

**SPACE NEEDED FOR INSTALLATION WITH ONE LEFT-HAND AND TWO RIGHT-HAND DRIVES**

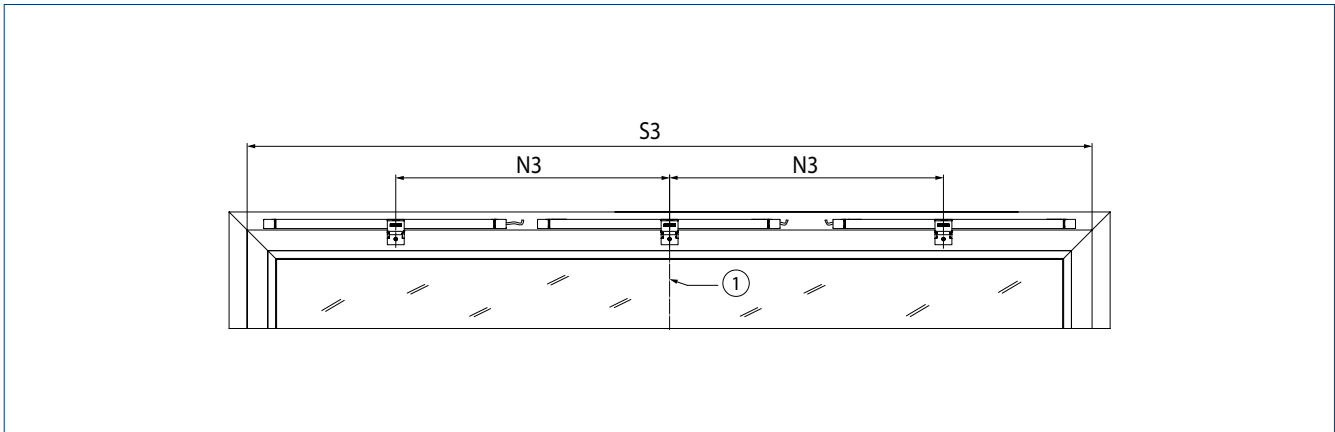

→ **Note:** Not suitable for side-hung windows. Dimensions for S3 and N3 see table I 1 = Centre of window

Stroke	N3 [mm]	S3 [mm] min.	ID no. EV1/ white RAL 9016	Quantity	ID no. EV1/ white RAL 9016	Quantity
300	640	1800	147030/147031 L, R	2	147030/147031 L, R	1
			147035/147036 L, R	1	147035/147036 L, R	2
500	700	2120	147040/147041 L, R	2	147040/147041 L, R	1
			147045/147046 L, R	1	147045/147046 L, R	2
800	850	2720	147050/147051 L, R	2	147050/147051 L, R	1
			147055/147056 L, R	1	147055/147056 L, R	2

**SPACE NEEDED FOR INSTALLATION WITH THREE RIGHT-HAND DRIVES**

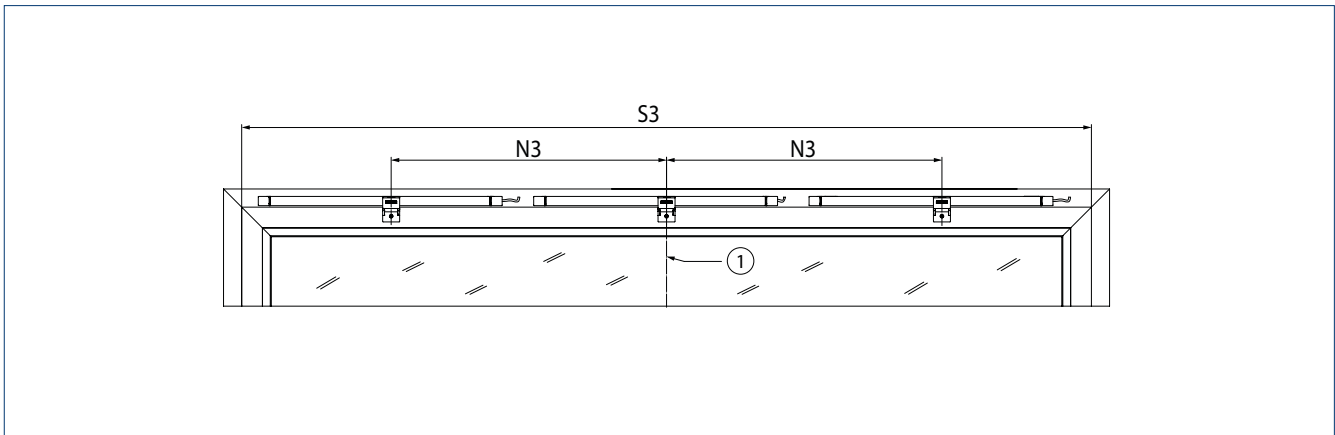

Dimensions for S3 and N3 see table I 1 = Centre of window

Stroke	N3 [mm]	S3 [mm] min.	ID no. EV1/white RAL 9016	Number	ID no. EV1/white RAL 9016	Quantity
300	600	1800	147030/147031 L, R	3	147030/147031 L, R	–
			147035/147036 L, R	–	147035/147036 L, R	3
500	700	2120	147040/147041 L, R	3	147040/147041 L, R	–
			147045/147046 L, R	–	147045/147046	3
800	850	2720	147050/147051 L, R	3	147050/147051 L, R	–
			147055/147056 L, R	–	147055/147056 L, R	3

**INSTALLATION DIMENSIONS – RECOMMENDATION**

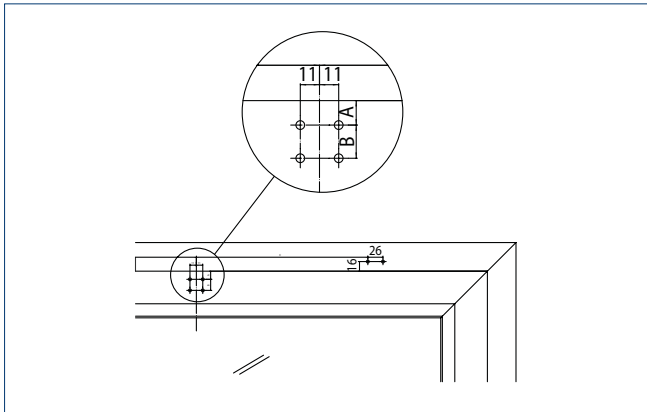
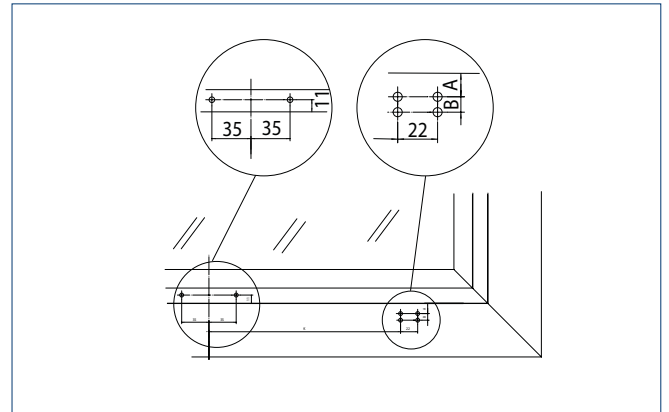
 Frame installation  
INWARD opening

 Leaf installation  
INWARD opening

 Frame installation  
OUTWARD opening

Material	Manufacturer	Profile system	Frame installation INWARD opening		Leaf installation INWARD opening 21 mm 4 screws		With 2 screws with rivet nuts	Frame installation OUTWARD opening		With 2 screws with rivet nuts
			A	B	A	B	A	A	B	A
Aluminium	Aluprof	MB-60	14	19	9	8	13	–	–	–
		MB-70	14	19	9	8	13	–	–	–
	Gutmann	S70	14	19	9	10	13	–	–	–
		Heroal	065	14	19	9	11	13	–	–
		110ES	14	19	9	9	13	–	–	16 <sup>1)</sup>
	Hueck	Lambda 65	14	19	9	11	13	11 <sup>2)3)</sup>	9 <sup>2)3)</sup>	15 <sup>2)</sup>
		Lambda 77	14	19	9	11	13	11 <sup>2)3)</sup>	9 <sup>2)3)</sup>	15 <sup>2)</sup>
	Raico	Frame+ 65 W	14	19	9	11	13	14 <sup>1)</sup>	17 <sup>1)</sup>	–
		Frame+ 75 WB	14	19	9	11	13	14 <sup>1)</sup>	17 <sup>1)</sup>	–
	Schueco	AWS 65	14	19	10	9	14	11	11	14
		AWS 75	14	19	10	9	14	11	11	14
	SAPA	1074	13 <sup>5)6)</sup>	18 <sup>5)6)</sup>	–	–	13	–	–	18 <sup>2)7)</sup>
		1086	13 <sup>5)8)</sup>	18 <sup>8)</sup>	–	–	13	–	–	–
	Wicona	Wicline 65 EVO	14	11	10	10	14	–	–	14 <sup>2)</sup>
Wicline 75 EVO		14	11	10	10	14	–	–	14 <sup>2)</sup>	
Plastic	EgoKiefer	AS1	17	11	11	8	17	–	–	–
	Profine	Kömmerling 88plus <sup>4)</sup>	18	14	11	8	11	–	–	–
	Veka	Alphaline 90	15	18	10	8	15	–	–	–
		Softline 82 MD	15	18	10	8	15	–	–	–
Wood	Gutmann	Mira	22	11	8	10	–	–	–	–
	Landgraf	IV79	22	11	8	10	–	–	–	–
	Oertli	IV68/IV80	22	11	8	10	–	–	–	–

All dimensions in mm

1) Installation dimension chain block 14 instead of 11

2) Installation dimension chain block 13 instead of 11

3) Only with tapping screws

4) On-site supports required, since overlap 24 mm

5) Installation dimension chain drive 18 instead of 16

6) All profile combinations containing profile number 74102, 74112, 74202 or 74203 allowed

7) All profile combinations containing profile number 74052 or 68713; A = 16 mm / installation dimension chain block 17 instead of 11

8) For all profile combinations containing profile number 86102 or 86202; A = 16 mm / installation dimension chain block 18 instead of 11

Further profile ranges on request.

ORDERING AID

LEAF INWARD OPENING FRAME INSTALLATION

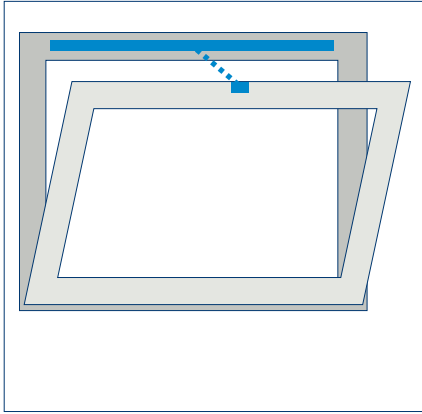

Bottom-hung leaf INWARD opening  
(drive can be swivelled)

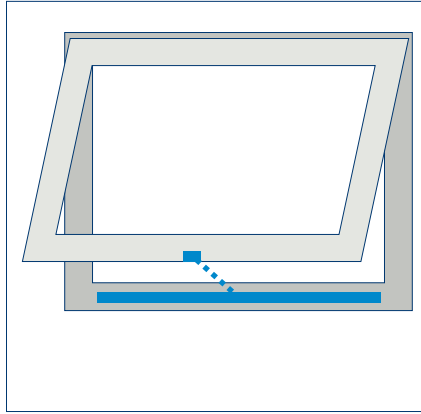

Top-hung leaf INWARD opening  
(drive can be swivelled)

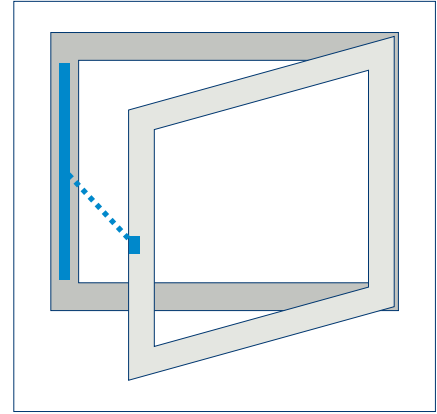

Side-hung leaf DIN R INWARD opening  
(drive cannot be swivelled)

Stroke	Version	Drive	Accessories
300	EV1	147030 Right	147060
300	white RAL 9016	147031 Right	147061
500	EV1	147040 Right	147060
500	white RAL 9016	147041 Right	147061
800	EV1	147050 Right	147060
800	white RAL 9016	147051 Right	147061

LEAF INWARD OPENING FRAME INSTALLATION

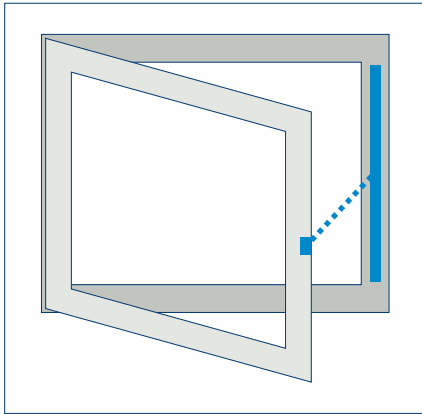

Side-hung leaf DIN L INWARD opening  
(drive cannot be swivelled)

Stroke	Version	Drive	Accessories
300	EV1	147035 Left	147060
300	white RAL 9016	147036 Left	147061
500	EV1	147045 Left	147060
500	white RAL 9016	147046 Left	147061
800	EV1	147055 Left	147060
800	white RAL 9016	147056 Left	147061



## ORDERING AID

## LEAF INWARD OPENING LEAF INSTALLATION

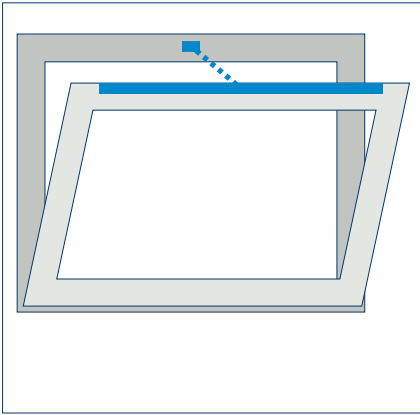

Bottom-hung leaf INWARD opening  
(drive cannot be swivelled)

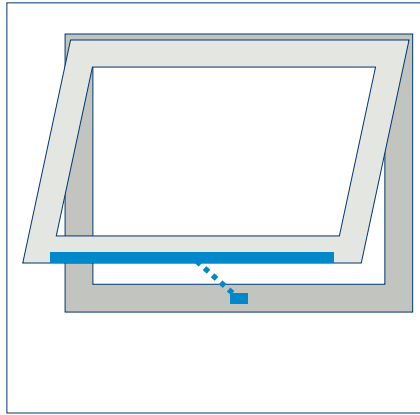

Top-hung leaf INWARD opening  
(drive cannot be swivelled)

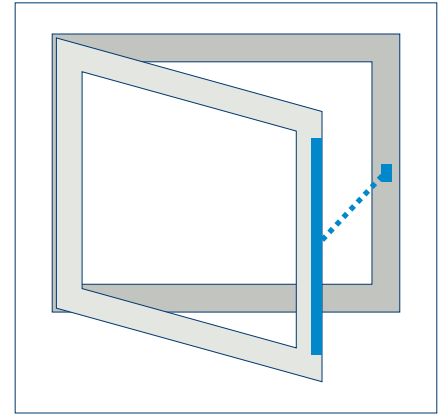

Side-hung leaf DIN L INWARD opening  
(drive cannot be swivelled)

Stroke	Version	Drive	Accessories
300	EV1	147030 Right	147062
300	white RAL 9016	147031 Right	147063
500	EV1	147040 Right	147062
500	white RAL 9016	147041 Right	147063
800	EV1	147050 Right	147062
800	white RAL 9016	147051 Right	147063

## LEAF INWARD OPENING LEAF INSTALLATION

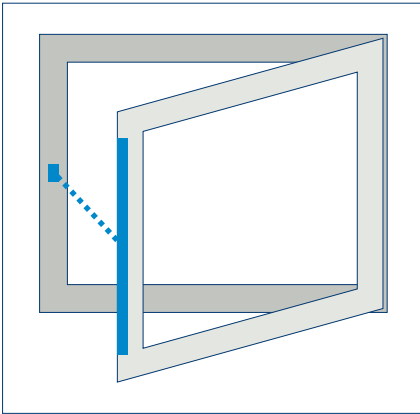

Side-hung leaf DIN R INWARD opening  
(drive cannot be swivelled)

Stroke	Version	Drive	Accessories
300	EV1	147035 Left	147062
300	white RAL 9016	147036 Left	147063
500	EV1	147045 Left	147062
500	white RAL 9016	147046 Left	147063
800	EV1	147055 Left	147062
800	white RAL 901	147056 Left	147063

ORDERING AID

LEAF OUTWARD OPENING FRAME INSTALLATION

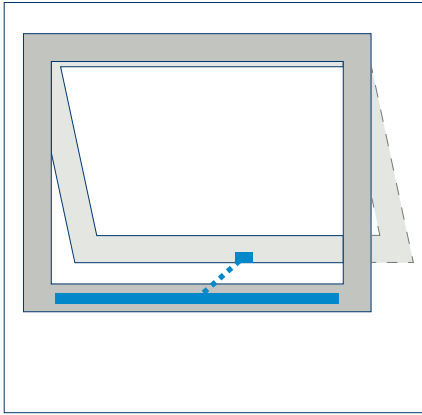

Top-hung leaf OUTWARD opening  
(drive can be swivelled)

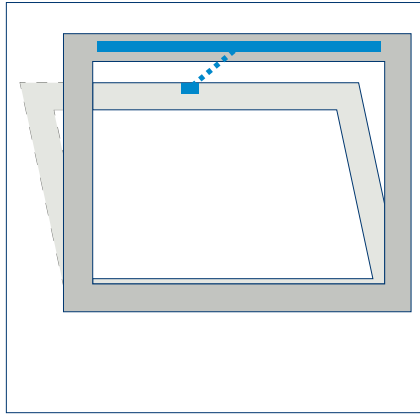

Bottom-hung leaf OUTWARD opening  
(drive can be swivelled)

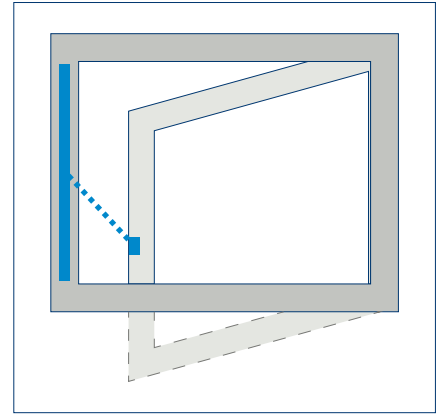

Side-hung leaf DIN L OUTWARD opening  
(drive cannot be swivelled)

Stroke	Version	Drive	Accessories
300	EV1	147030 Right	147062
300	white RAL 9016	147031 Right	147063
500	EV1	147040 Right	147062
500	white RAL 9016	147041 Right	147063
800	EV1	147050 Right	147062
800	white RAL 9016	147051 Right	147063

LEAF OUTWARD OPENING FRAME INSTALLATION

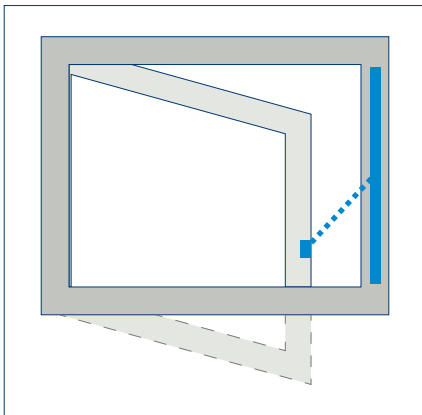

Side-hung leaf DIN R OUTWARD opening  
(drive cannot be swivelled)

Stroke	Version	Drive	Accessories
300	EV1	147035 Left	147062
300	white RAL 9016	147036 Left	147063
500	EV1	147045 Left	147062
500	white RAL 9016	147046 Left	147063
800	EV1	147055 Left	147062
800	white RAL 9016	147056 Left	147063

## ORDER INFORMATION

Designation	Stroke	Version	ID no.
Slimchain L	300 mm	EV1	147035
	300 mm	white RAL 9016	147036
	500 mm	EV1	147045
	500 mm	white RAL 9016	147046
	800 mm	EV1	147055
	800 mm	white RAL 9016	147056
Slimchain R	300 mm	EV1	147030
	300 mm	white RAL 9016	147031
	500 mm	EV1	147040
	500 mm	white RAL 9016	147041
	800 mm	EV1	147050
	800 mm	white RAL 9016	147051
Slimchain - special version Can be configured: stroke, cable length, colour, version L/R			147070
<b>ACCESSORIES</b>			
Console set A Slimchain For bottom-hung, side-hung and top-hung windows, frame installation INWARD opening		white RAL 9016 black	147061 147060
Console set B Slimchain For bottom-hung, side-hung and top-hung windows, leaf installation INWARD opening and frame installation OUTWARD opening		white RAL 9016 black	147063 147062
Console set C Slimchain For bottom-hung, side-hung windows, frame installation integrated INWARD opening		silver	155878
Console set P Slimchain For parallel opening windows, top-hung/bottom-hung windows and projected top hung windows, frame installation OUTWARD opening		white RAL 9016 black according to RAL	164396 164394 164397
Choice of consoles for Slimchain Can be configured: Type of opening, colour		112365	147071

# Console sets



Console set A Slimchain  
(147060)



Console set B Slimchain  
(147062)



Console set C Slimchain  
(155878)



Console set P Slimchain  
(164394)

# Slimchain 230 V



Chain drive in an attractive design with numerous possible applications in 230 V finish

## AREAS OF APPLICATION

- Natural ventilation in the façade area
- Inward and outward opening bottom-, top- and side-hung windows
- Outward opening projected top hung windows
- Installation on wooden, PVC or metal windows
- Leaf, frame or integrated installation

## PRODUCT FEATURES

- Slim and discreet appearance integrates perfectly into the façade design
- Fast and easy installation with the GEZE Smart fix installation system
- Direct 230 V connection of the drive via a connection terminal with cable plug
- Concealed line-feed 230 V
- Direct access to the electronics for setting parameters via service cover
- Drive stroke with variable adjustment
- Available as special version - stroke, cable length, colour and alignment configurable to left/right

**TECHNICAL DATA****Slimchain 230 V****GENERAL INFORMATION**

Length	Stroke 200: 540 mm, stroke 300: 590 mm, stroke 500: 690 mm, stroke 800: 840 mm (each with consoles)
Height	25 mm
Depth	44 mm
Space needed on frame (min.)	Frame installation inward opening: 40 mm, leaf installation inward opening: 16/21 mm, frame installation outward opening: 31 mm
Space needed on leaf (min.)	Frame installation inward opening: 40 mm, leaf installation inward opening: 34/29 mm, frame installation outward opening: 19 mm

**SPECIFICATIONS**

Possible stroke lengths	200 mm, 300 mm, 500 mm, 800 mm
Factory presetting	Ventilation stroke 300 mm
Opening speed ventilation	5 mm/s
Closing speed	5 mm/s
Tensile force (max.)	300 N
Compressive force (max.)	200 N (depending on stroke), see force-path chart
Holding force (max.)	2000 N
Leaf weight (max.) <sup>1)</sup>	200 kg
Overlap range <sup>2)</sup>	0 - 23 mm

**ELECTRICAL DATA**

Operating voltage	230 V ± 10 %
Current consumption	0.3 A
Power consumption (max.)	30 W
Duty rating	30 %
Length of power supply cable	2 m
Special length of power supply cable	5 m, 7.5 m
Cable dimensions	3 x 0.75 mm <sup>2</sup>
Temperature range	-5 – 70 °C
IP rating / protection rating	IP30 / II

**FUNCTIONS**

Stroke length settable	●
Opening speed settable (ventilation)	●
Type of stroke shortening	Synchronising unit, factory setting
End position cut-off extended	electronically via internal path sensor
End position cut-off retracted	electric, electronic via current consumption
Overload cut-off	●

**TYPES OF INSTALLATION**

Bottom-hung window	inward opening outward opening	Frame / leaf Frame
Side-hung window	inward opening outward opening	Frame / leaf Frame
Top-hung window	inward opening outward opening	Frame / leaf Frame
Projected top hung window	outward opening	Frame

● = YES | 1 = The total weight is limited by the hinges and depends on the details provided by the profile system manufacturer. | 2 = Depending on the application and the console set

**PRODUCT SCALE DRAWING**

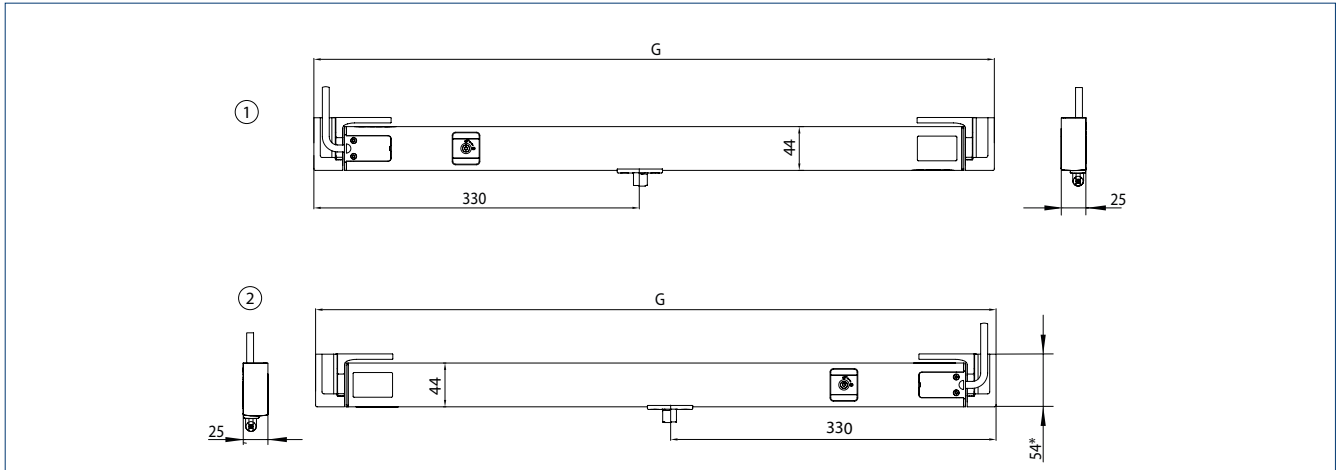

G = Length | 1 = GEZE Slimchain 230 V L | 2 = GEZE Slimchain 230 V R | \* = Console set A

**TYPES OF INSTALLATION**

**Frame installation  
INWARD opening**

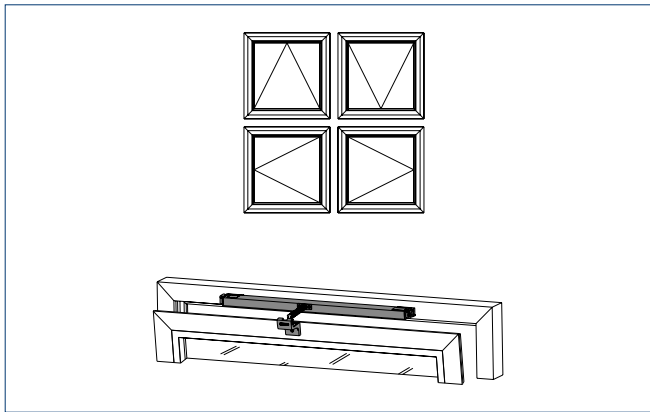

Console set B | 1 = on request

**Leaf installation  
INWARD opening**

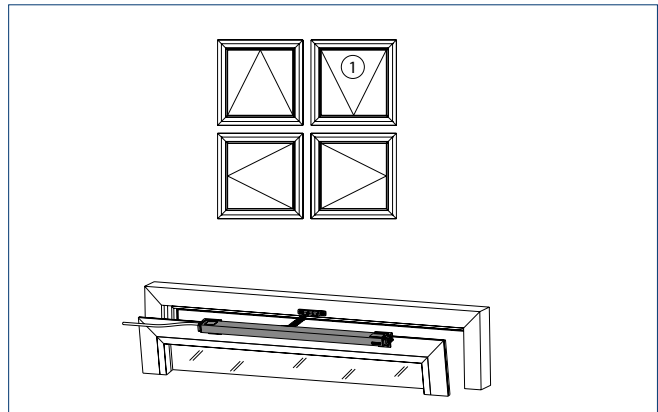

**Frame installation  
OUTWARD opening**

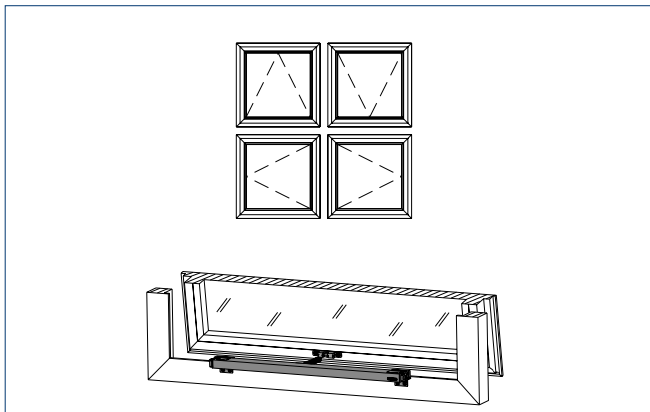

Console set B

**Frame installation  
OUTWARD opening  
Projected top hung window / parallel opening window**

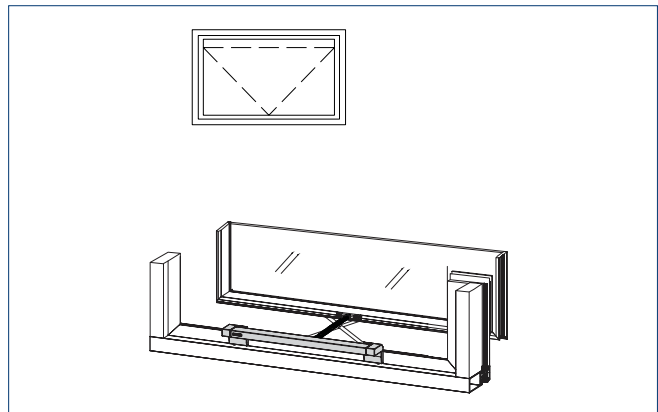

Console set P

**FORCE-PATH CHART**

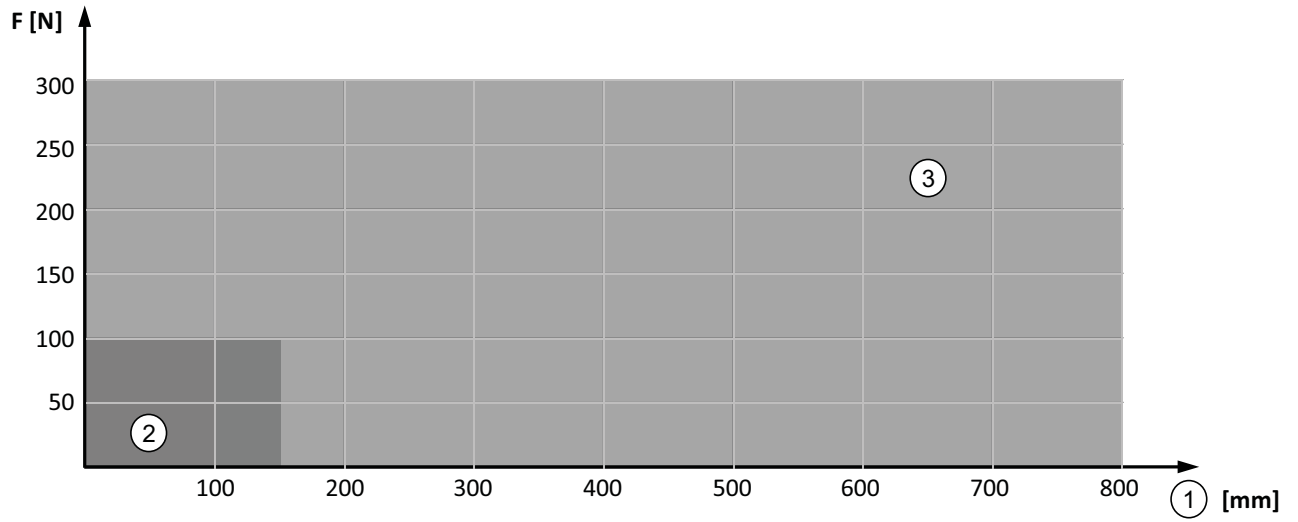

F = Force | 1 = Stroke | 2 = Pressure | 3 = Tension

**AREA OF APPLICATION BOTTOM-HUNG WINDOW FRAME INSTALLATION INWARD OPENING (DRIVE CAN BE SWIVELLED) / BOTTOM-HUNG WINDOW FRAME INSTALLATION OUTWARD OPENING (DRIVE CAN BE SWIVELLED)**

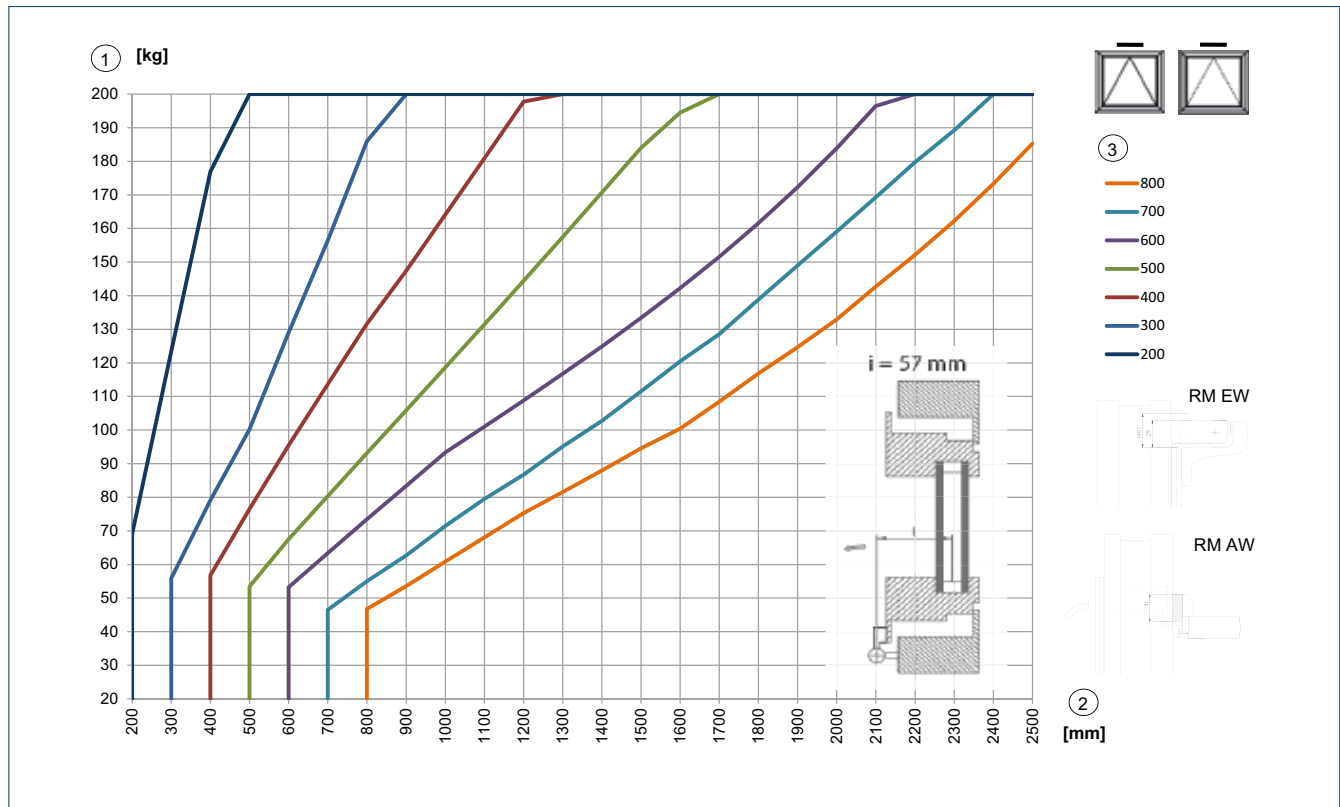

Area of application applies for one Solo drive, for Syncro 2 or Syncro 3 the leaf weight can be doubled or tripled. The details provided by the profile system manufacturer must be heeded. 1 = Leaf weight | 2 = Secondary closing edge | 3 = Stroke [mm] | RM EW = Frame installation INWARD opening | RM AW = Frame installation OUTWARD opening

**AREA OF APPLICATION BOTTOM-HUNG WINDOW LEAF INSTALLATION INWARD OPENING (DRIVE CANNOT BE SWIVELLED) AND FOR INTEGRATED INSTALLATION**

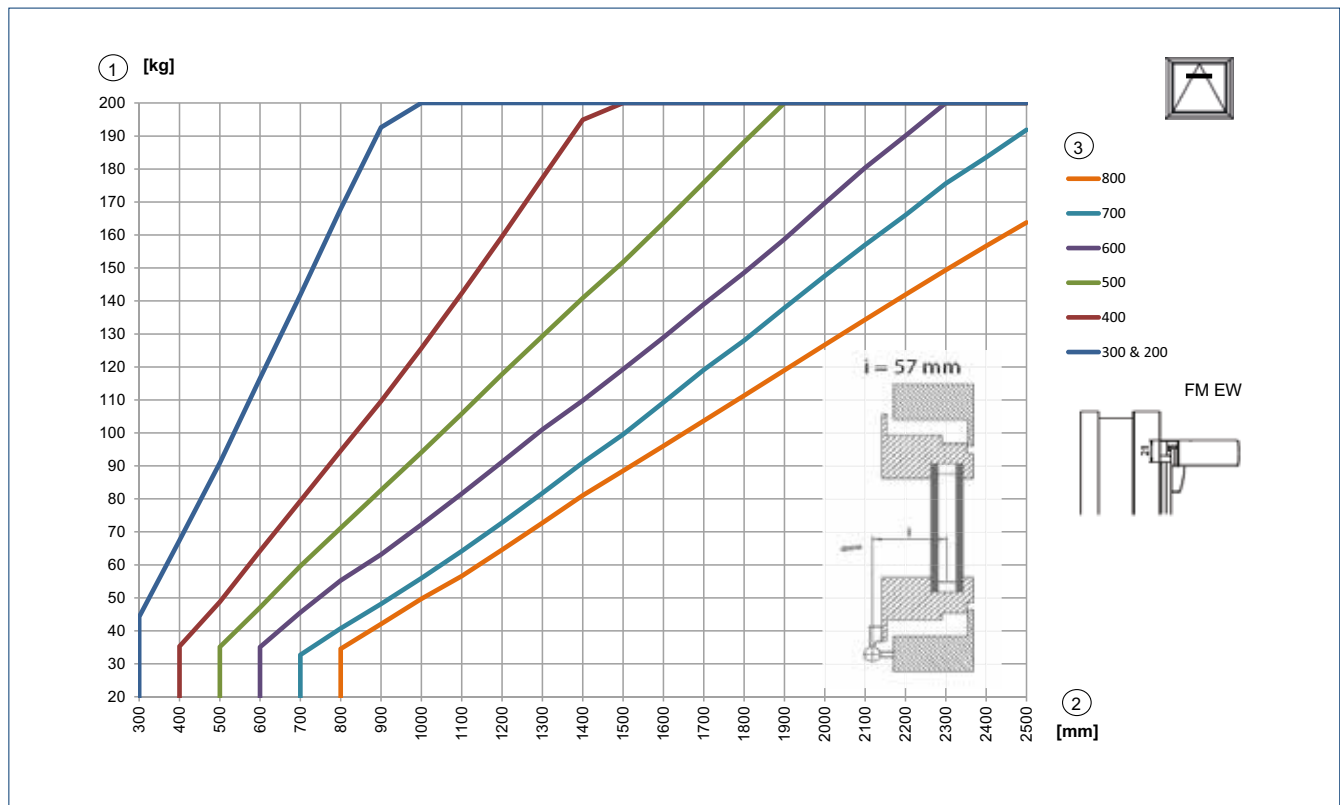

Area of application applies for one Solo drive, for Syncro 2 or Syncro 3 the leaf weight can be doubled or tripled. The details provided by the profile system manufacturer must be heeded. 1 = Leaf weight | 2 = Secondary closing edge | 3 = Stroke [mm]



**MINIMUM LEAF WIDTH SIDE-HUNG WINDOW FRAME INSTALLATION INWARD OPENING / SIDE-HUNG WINDOW FRAME INSTALLATION OUTWARD OPENING (DRIVE CANNOT BE SWIVELLED)**

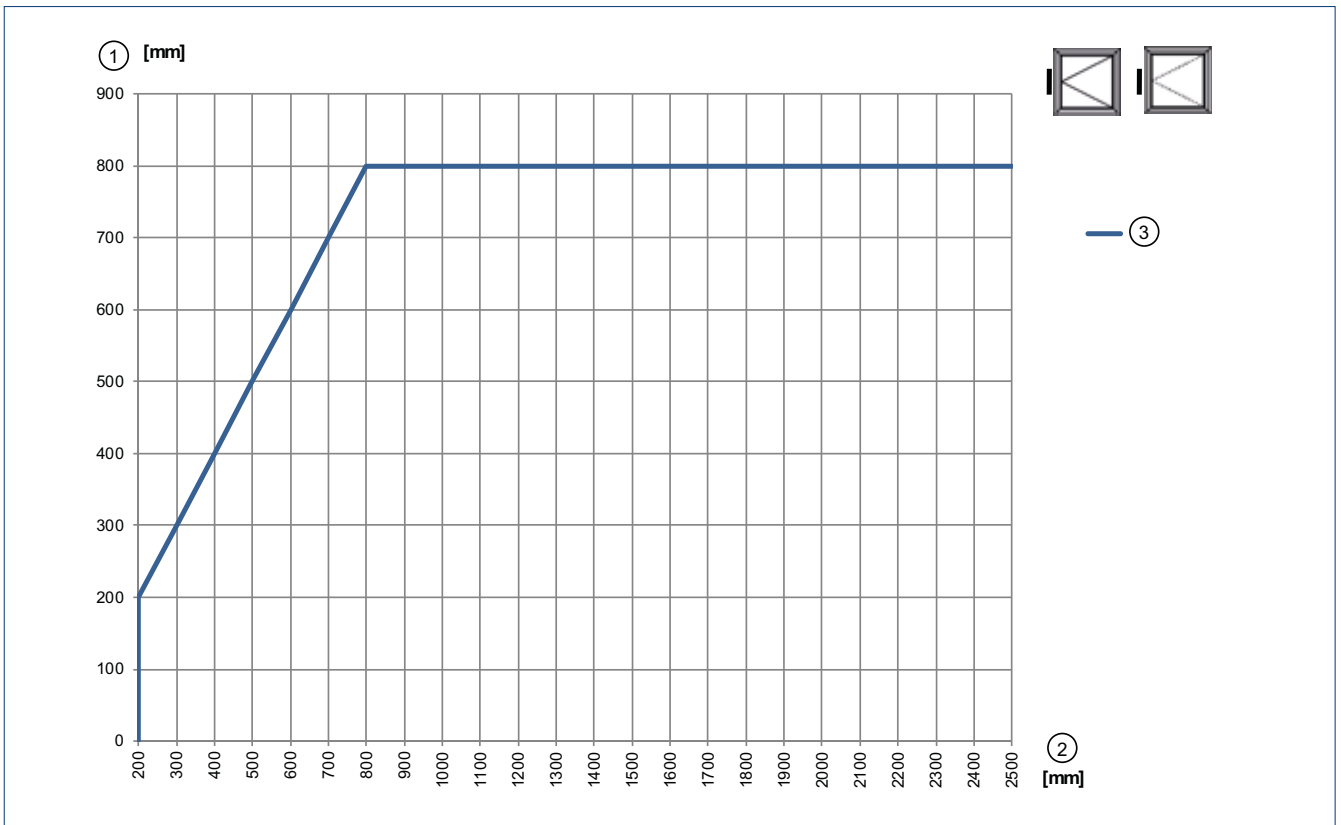

1 = Stroke | 2 = Secondary closing edge | 3 = Ventilation

**MINIMUM LEAF WIDTH SIDE-HUNG WINDOW LEAF INSTALLATION INWARD OPENING (DRIVE CANNOT BE SWIVELLED) AND FOR INTEGRATED INSTALLATION**

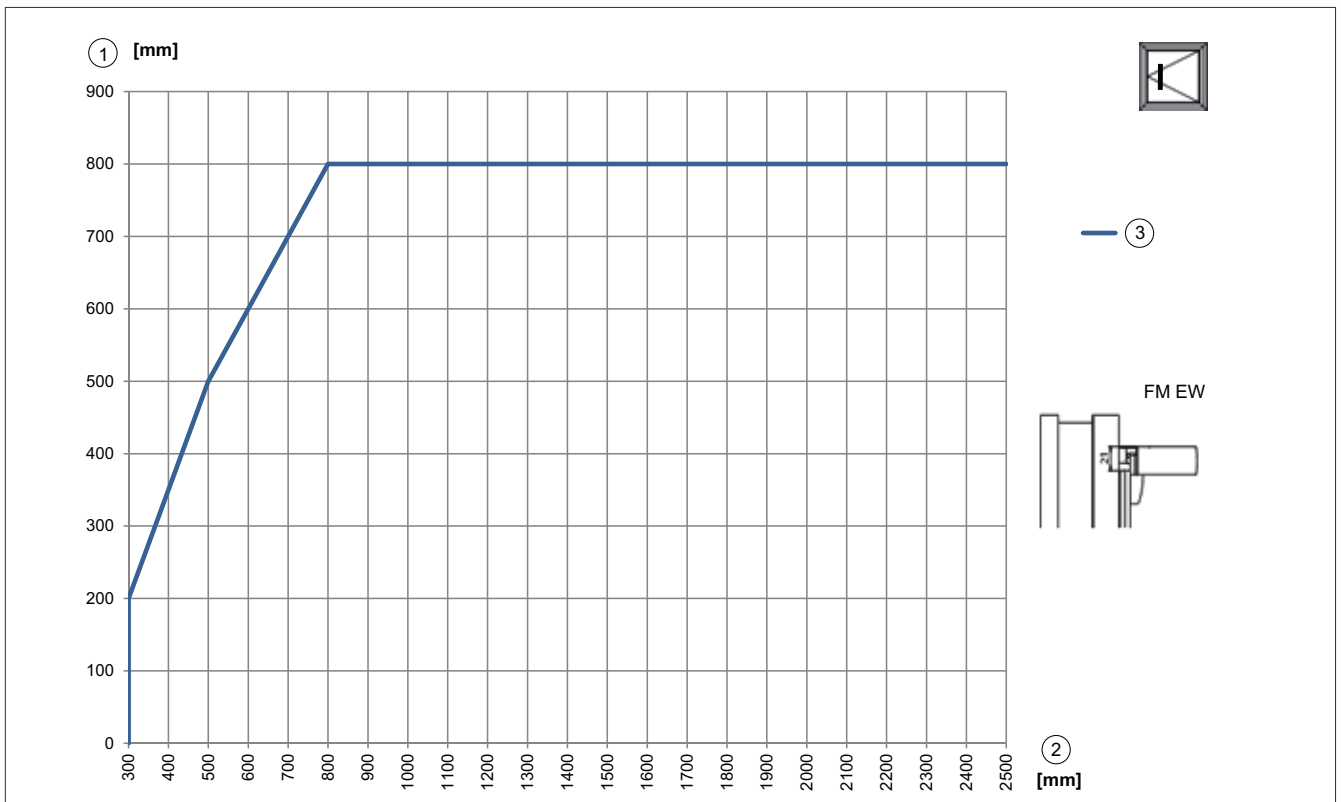

1 = Stroke | 2 = Secondary closing edge | 3 = Ventilation

**AREA OF APPLICATION TOP-HUNG WINDOW FRAME INSTALLATION OUTWARD OPENING (DRIVE CAN BE SWIVELLED)**

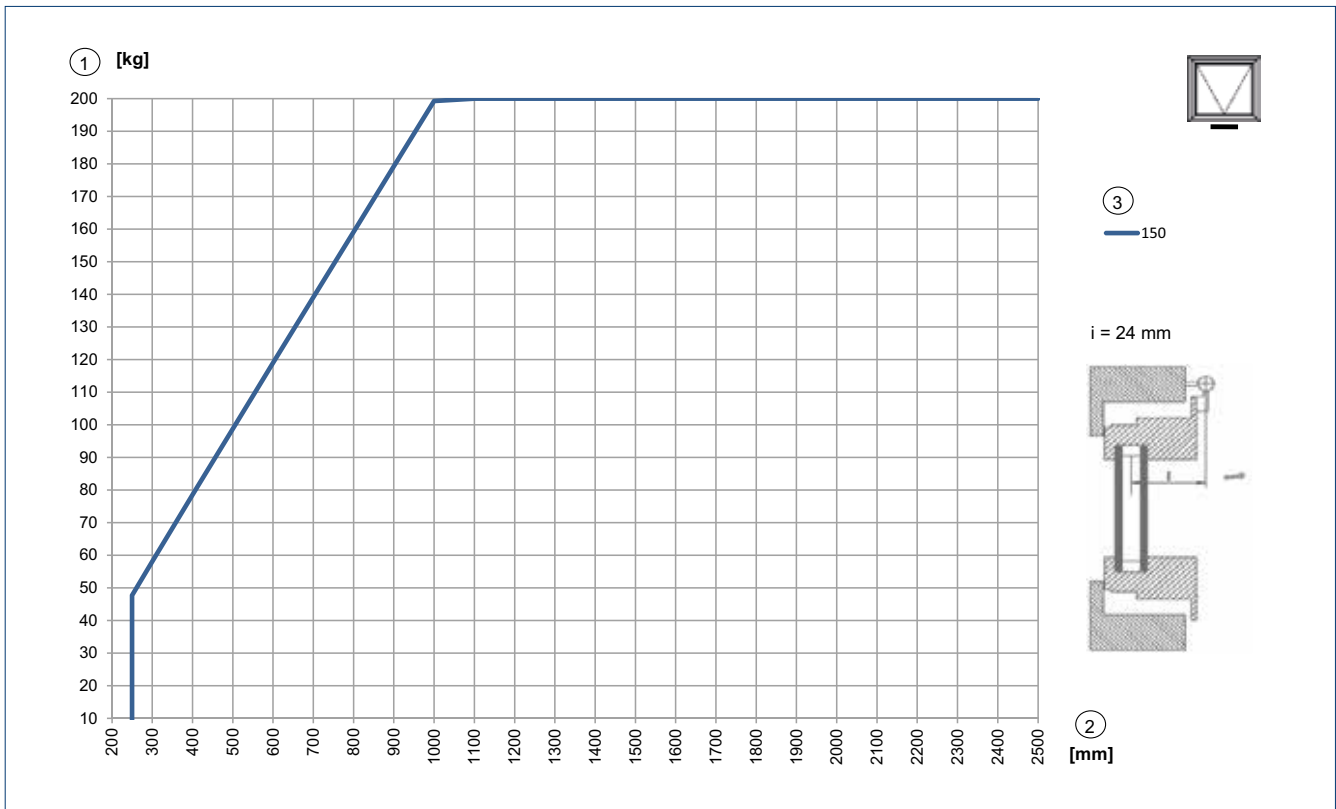

Area of application applies for one Solo drive, for Syncro 2 or Syncro 3 the leaf weight can be doubled or tripled. The details provided by the profile system manufacturer must be heeded. 1 = Leaf weight | 2 = Secondary closing edge | 3 = Stroke [mm]

**AREA OF APPLICATION TOP-HUNG WINDOW FRAME INSTALLATION INWARD OPENING (DRIVE CAN BE SWIVELLED) / TOP-HUNG WINDOW LEAF INSTALLATION INWARD OPENING (DRIVE CAN NOT BE SWIVELLED) AND FOR INTEGRATED INSTALLATION**

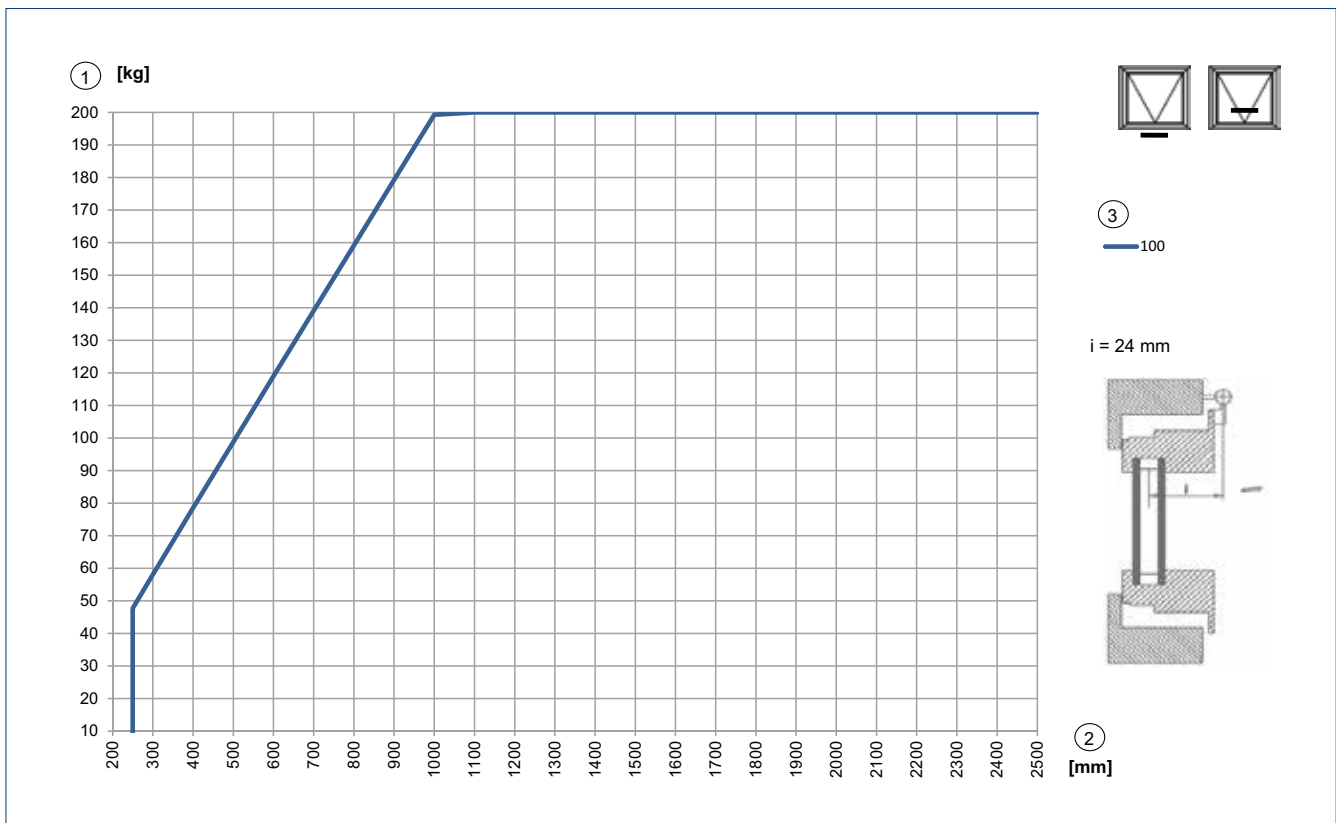

1 = Leaf weight | 2 = Secondary closing edge | 3 = Stroke [mm]

## SPACE NEEDED

Stroke	E [mm]	G [mm]	S [mm]
200	210	540	660
300	260	590	660
500	360	660	720
800	510	840	1020

→ **Note:** Illustrations with cable side left, cable side right is reversed

### SPACE NEEDED FOR FRAME INSTALLATION INWARD OPENING

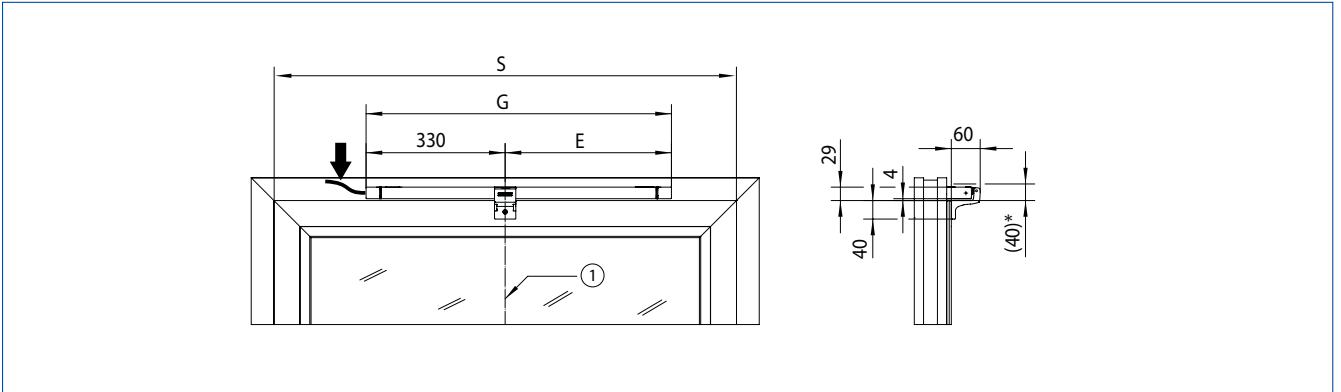

See table for dimensions for E, G and S  
1 = Centre of window | \* = Swivelling range

### SPACE NEEDED FOR LEAF INSTALLATION INWARD OPENING

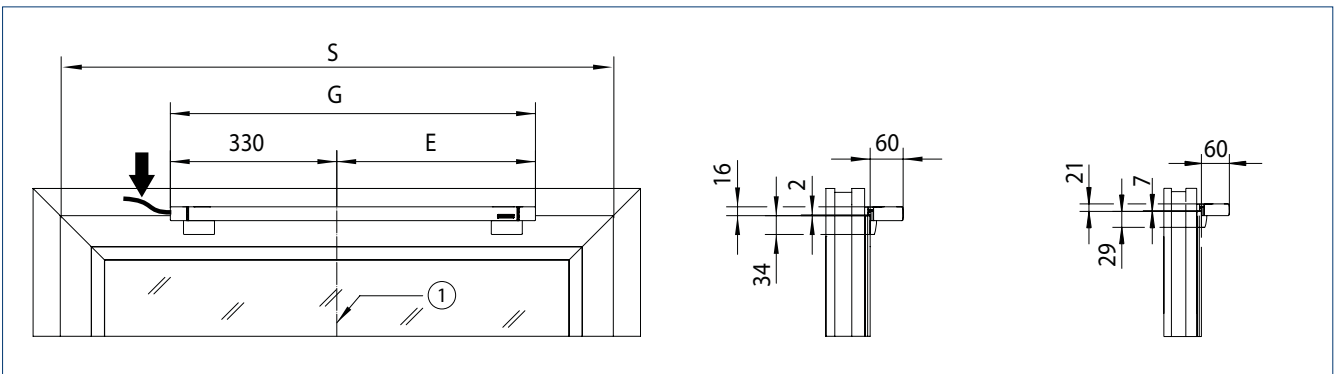

See table for dimensions for E, G and S  
1 = Centre of window

### SPACE NEEDED FOR FRAME INSTALLATION OUTWARD OPENING

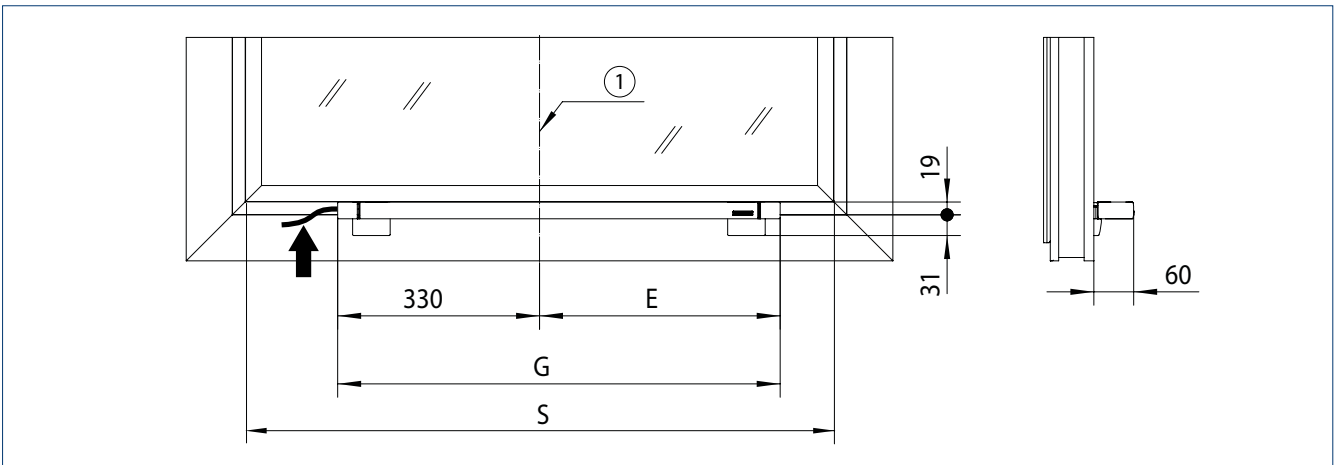

See table for dimensions for E, G and S  
1 = Centre of window

## INSTALLATION DIMENSIONS - RECOMMENDATION

Frame installation  
INWARD opening

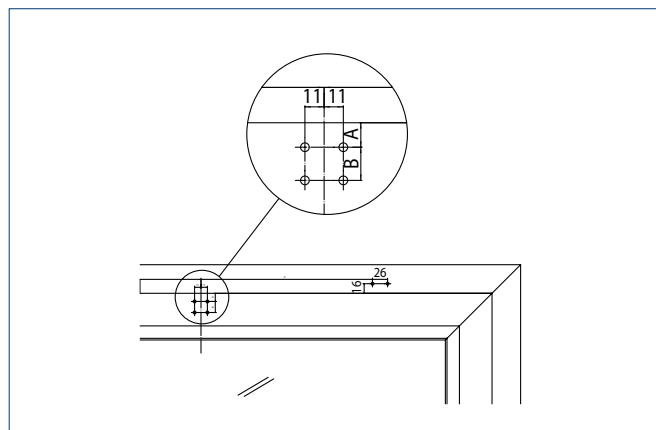

Leaf installation  
INWARD opening

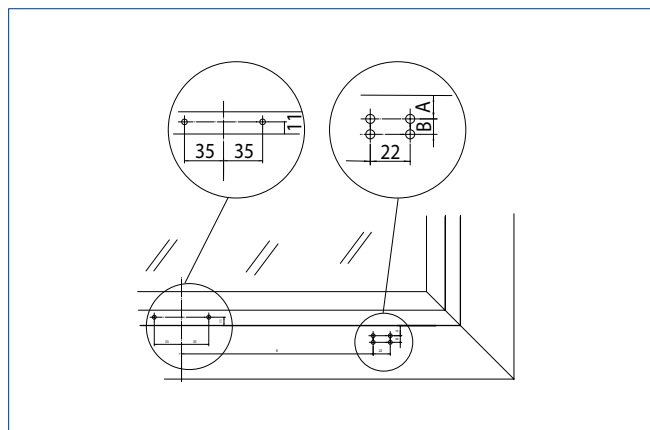

Frame installation  
OUTWARD opening

Material	Manufacturer Profile system	Frame installation INWARD opening		Leaf installation INWARD opening 21 mm 4 screws		With 2 screws with rivet nuts	Frame installation OUTWARD opening		With 2 screws with rivet nuts	
		A	B	A	B	A	A	B	A	
Aluminium	Aluprof	MB-60	14	19	9	8	13	-	-	-
		MB-70	14	19	9	8	13	-	-	-
	Gutmann	S70	14	19	9	10	13	-	-	-
		065	14	19	9	11	13	-	-	16 <sup>1)</sup>
	Heroal	110ES	14	19	9	9	13	-	-	16 <sup>1)</sup>
		Lambda 65	14	19	9	11	13	11 <sup>2) 3)</sup>	9 <sup>2) 3)</sup>	15 <sup>2)</sup>
	Hueck	Lambda 77	14	19	9	11	13	11 <sup>2) 3)</sup>	9 <sup>2) 3)</sup>	15 <sup>2)</sup>
		Raico	Frame+ 65 W	14	19	9	11	13	14 <sup>1)</sup>	17 <sup>1)</sup>
	Frame+ 75 WB		14	19	9	11	13	14 <sup>1)</sup>	17 <sup>1)</sup>	-
	Schueco	AWS 65	14	19	10	9	14	11	11	14
		AWS 75	14	19	10	9	14	11	11	14
	SAPA	1074	13 <sup>5) 6)</sup>	18 <sup>5) 6)</sup>	-	-	13	-	-	18 <sup>2) 7)</sup>
		1086	13 <sup>5) 8)</sup>	18 <sup>8)</sup>	-	-	13	-	-	-
	Wicona	Wicline 65 EVO	14	11	10	10	14	-	-	14 <sup>2)</sup>
Wicline 75 EVO		14	11	10	10	14	-	-	14 <sup>2)</sup>	
Plastic	EgoKiefer	AS1	17	11	11	8	17	-	-	-
	Profine	Kömmerling 88plus <sup>4)</sup>	18	14	11	8	11	-	-	-
		Alphaline 90	15	18	10	8	15	-	-	-
	Veka	Softline 82 MD	15	18	10	8	15	-	-	-
Wood		Gutmann	Mira	22	11	8	10	-	-	-
	Landgraf	IV79	22	11	8	10	-	-	-	
	Oertli	IV68/IV80	22	11	8	10	-	-	-	

All dimensions in mm

1) Installation dimension chain block 14 instead of 11

2) Installation dimension chain block 13 instead of 11

3) Only with tapping screws

4) On-site supports required, since overlap 24 mm

5) Installation dimension chain drive 18 instead of 16

6) All profile combinations containing profile number 74102, 74112, 74202 or 74203 allowed

7) All profile combinations containing profile number 74052 or 68713; A = 16 mm / installation dimension chain block 17 instead of 11

8) For all profile combinations containing profile number 86102 or 86202; A = 16 mm / installation dimension chain block 18 instead of 11

Further profile ranges on request.

## ORDERING AID

### LEAF INWARD OPENING FRAME INSTALLATION

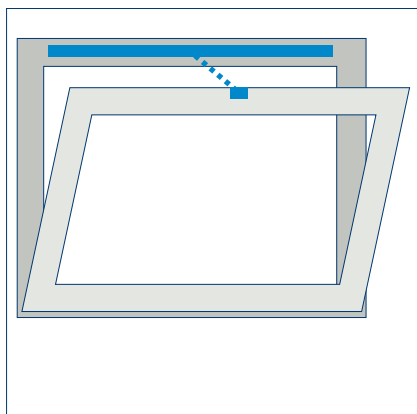

Bottom-hung leaf INWARD opening  
(drive can be swivelled)

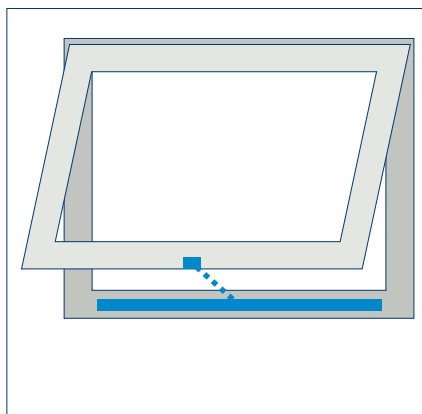

Top-hung leaf INWARD opening  
(drive can be swivelled)

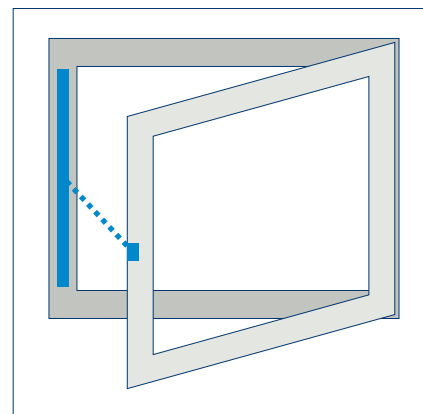

Side-hung leaf DIN R INWARD opening  
(drive cannot be swivelled)

Stroke	Version	Drive	Accessories
200	EV1	182582 Right	147060
200	white RAL 9016	182583 Right	147061
300	EV1	182586 Right	147060
300	white RAL 9016	182587 Right	147061
500	EV1	182590 Right	147060
500	white RAL 9016	182591 Right	147061
800	EV1	182594 Right	147060
800	white RAL 9016	182595 Right	147061

### LEAF INWARD OPENING FRAME INSTALLATION

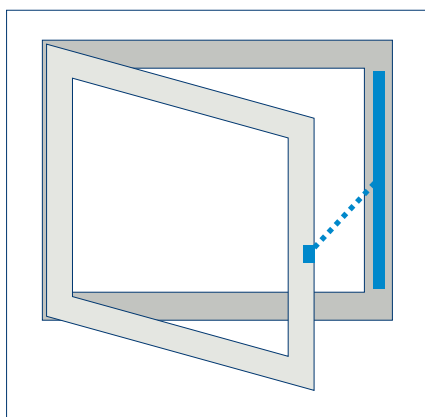

Side-hung leaf DIN L INWARD opening  
(drive cannot be swivelled)

Stroke	Version	Drive	Accessories
200	EV1	182570 Left	147060
200	white RAL 9016	182571 Left	147061
300	EV1	182584 Left	147060
300	white RAL 9016	182585 Left	147061
500	EV1	182588 Left	147060
500	white RAL 9016	182589 Left	147061
800	EV1	182592 Left	147060
800	white RAL 9016	182593 Left	147061

## ORDERING AID

### LEAF INWARD OPENING LEAF INSTALLATION

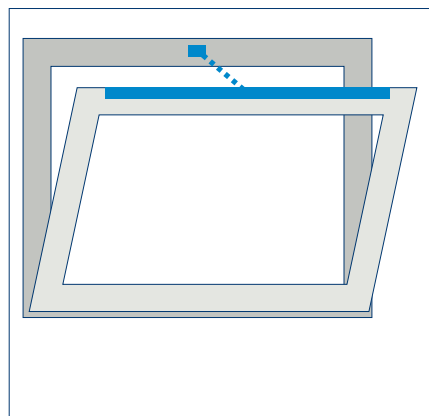

Bottom-hung leaf INWARD opening  
(drive cannot be swivelled)

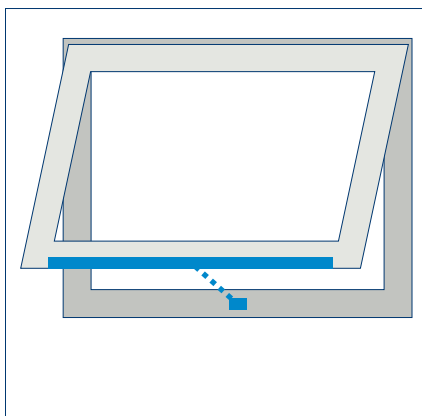

Top-hung leaf INWARD opening  
(drive cannot be swivelled)

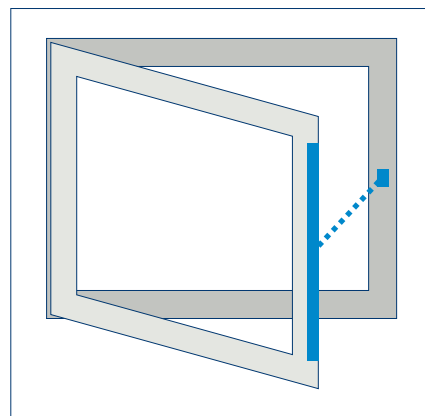

Side-hung leaf DIN L INWARD opening  
(drive cannot be swivelled)

Stroke	Version	Drive	Accessories
200	EV1	182582 Right	147062
200	white RAL 9016	182583 Right	147063
300	EV1	182586 Right	147062
300	white RAL 9016	182587 Right	147063
500	EV1	182590 Right	147062
500	white RAL 9016	182591 Right	147063
800	EV1	182594 Right	147062
800	white RAL 9016	182595 Right	147063

### LEAF INWARD OPENING LEAF INSTALLATION

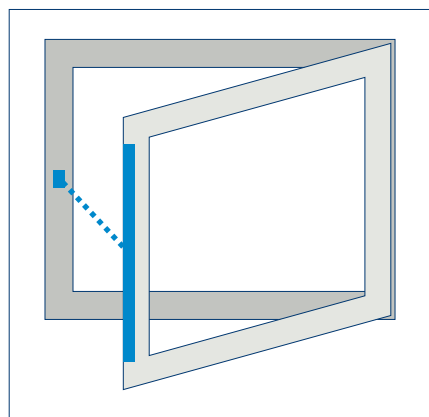

Side-hung leaf DIN R INWARD opening  
(drive cannot be swivelled)

Stroke	Version	Drive	Accessories
200	EV1	182570 Left	147062
200	white RAL 9016	182571 Left	147063
300	EV1	182584 Left	147062
300	white RAL 9016	182585 Left	147063
500	EV1	182588 Left	147062
500	white RAL 9016	182589 Left	147063
800	EV1	182592 Left	147062
800	white RAL 9016	182593 Left	147063

## ORDERING AID

## LEAF OUTWARD OPENING FRAME INSTALLATION

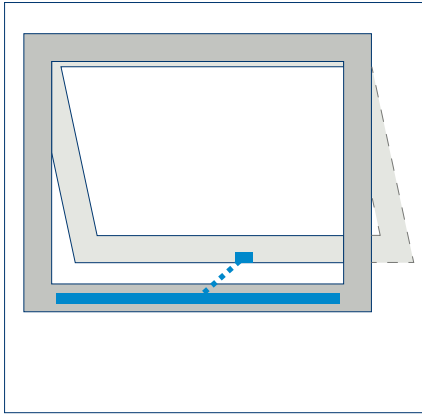

Top-hung leaf OUTWARD opening  
(drive can be swivelled)

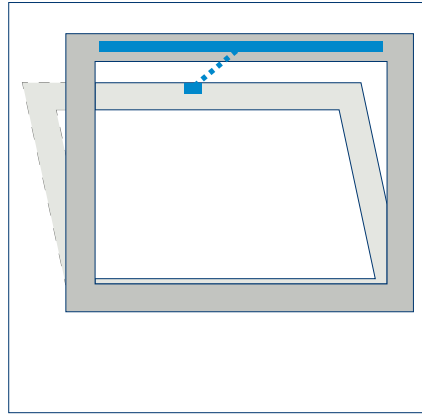

Bottom-hung leaf OUTWARD opening  
(drive can be swivelled)

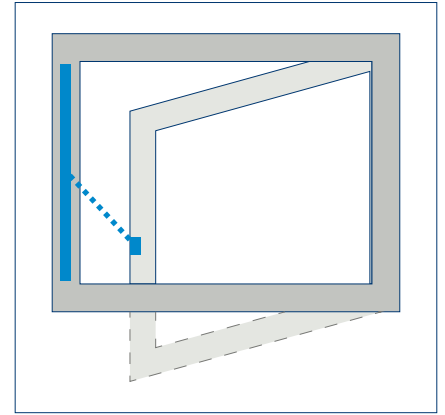

Side-hung leaf DIN L OUTWARD opening  
(drive cannot be swivelled)

Stroke	Version	Drive	Accessories
200	EV1	182582 Right	147062
200	white RAL 9016	182583 Right	147063
300	EV1	182586 Right	147062
300	white RAL 9016	182587 Right	147063
500	EV1	182590 Right	147062
500	white RAL 9016	182591 Right	147063
800	EV1	182594 Right	147062
800	white RAL 9016	182595 Right	147063

## LEAF OUTWARD OPENING FRAME INSTALLATION

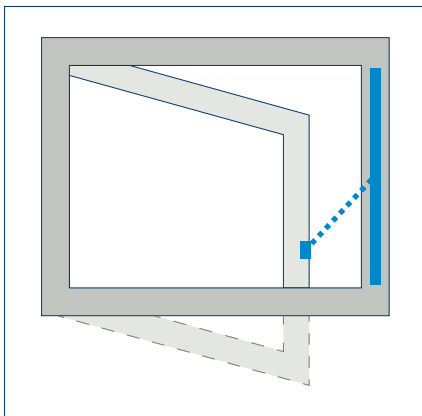

Side-hung leaf DIN R OUTWARD opening  
(drive cannot be swivelled)

Stroke	Version	Drive	Accessories
200	EV1	182570 Left	147062
200	white RAL 9016	182571 Left	147063
300	EV1	182584 Left	147062
300	white RAL 9016	182585 Left	147063
500	EV1	182588 Left	147062
500	white RAL 9016	182589 Left	147063
800	EV1	182592 Left	147062
800	white RAL 9016	182593 Left	147063

## ORDER INFORMATION

Designation	Stroke	Version	ID no.
Slimchain 230 V L	200 mm	EV1	182570
	200 mm	white RAL 9016	182571
	300 mm	EV1	182584
	300 mm	white RAL 9016	182585
	500 mm	EV1	182588
	500 mm	white RAL 9016	182589
	800 mm	EV1	182592
	800 mm	white RAL 9016	182593
Slimchain 230 V R	200 mm	EV1	182582
	200 mm	white RAL 9016	182583
	300 mm	EV1	182586
	300 mm	white RAL 9016	182587
	500 mm	EV1	182590
	500 mm	white RAL 9016	182591
	800 mm	EV1	182594
	800 mm	white RAL 9016	182595
Slimchain - special version Can be configured: stroke, cable length, colour, version L/R			182596
<b>ACCESSORIES</b>			
Console set A Slimchain For bottom-hung, side-hung and top-hung windows, frame installation INWARD opening		white RAL 9016 black	147061 147060
Console set B Slimchain For bottom-hung, side-hung and top-hung windows, leaf installation INWARD opening and frame installation OUTWARD opening		white RAL 9016 black	147063 147062
Console set C Slimchain For bottom-hung, side-hung windows, frame installation integrated INWARD opening		silver	155878
Console set P Slimchain For top-/ bottom-hung windows, frame installation OUTWARD opening, projected top hung windows frame installation OUTWARD opening		white RAL 9016 black according to RAL	164396 164394 164397
Choice of consoles for Slimchain Can be configured: Type of opening, colour		according to RAL	147071

# Console sets



Console set A Slimchain  
(147060)



Console set B Slimchain  
(147062)



Console set C Slimchain  
(155878)



Console set P Slimchain  
(164394)



# Powerchain



Chain drive for large and heavy window elements  
that need large opening widths

## AREAS OF APPLICATION

- Smoke and heat extraction system and natural ventilation (24 V) in the façade and roof area
- Can be used in the exhaust air and air intake
- Inward and outward opening windows with bottom-hung, top-hung, side-hung leaves
- Roof windows
- Installation on wooden, PVC or metal windows
- Leaf and frame installation
- Synchronisation of up to four drives
- System solution in combination with the Power lock locking drive

## PRODUCT FEATURES

- Fast opening speeds when smoke and heat extraction is needed, even for very heavy windows
- Drive stroke with variable adjustment and individual speeds for ventilation and smoke and heat extraction
- Available as special version - stroke, cable length and colour configurable
- Synchronisation of max. four drives without external control unit
- DIP switches for changing over the mode of operation (Solo and Syncro, master, slave)
- Fast and easy installation with the GEZE Smart fix installation system
- IQ windowdrive - intelligent drive control
- SHEV tested according to EN 12101-2

## TECHNICAL DATA

<b>Powerchain</b>	
<b>GENERAL INFORMATION</b>	
Length	stroke 600: 756 mm, stroke 800: 856 mm, stroke 1200: 1056 mm (each with consoles)
Height	36 mm
Depth	51 mm
Space needed on frame (min.)	frame installation inward opening: 50/61 mm (for side-hung leaf DIN L), leaf installation inward opening: 30/41 mm (for side-hung leaf DIN R), frame installation outward opening: 50 mm
Space needed on leaf (min.)	frame installation inward opening: 40 mm, leaf installation inward opening: 50 mm frame installation outward opening 30/41 mm (for side-hung leaf DIN R)
<b>SPECIFICATIONS</b>	
Possible stroke lengths	600 mm, 800 mm, 1200 mm
Factory presetting	ventilation stroke 300 mm (slow speed), alarm stroke full opening width (fast speed)
Opening speed smoke and heat extraction	15 mm/s
Opening speed ventilation	5 mm/s
Closing speed	5 mm/s
Tensile force (max.)	600 N
Compressive force (max.)	600 N (depending on stroke), see force-path diagram
Holding force (max.)	3000 N
Leaf weight (max.) <sup>1)</sup>	200 kg
Overlap range <sup>2)</sup>	0 – 23 mm
<b>ELECTRICAL DATA</b>	
Operating voltage	24 V ± 25 %
Current consumption	ventilation (24 V): 1.2 A; smoke and heat extraction (18 V): 1.5 A
Power consumption (max.)	36 W
Duty rating	30 %
Length of power supply cable	2 m
Special length of power supply cable	5 m, 7,5 m
Cable dimensions	4 x 0.75 mm <sup>2</sup>
Temperature range	-5 – 70 °C
IP rating / protection rating	IP40 / III
<b>FUNCTIONS</b>	
Stroke length settable	●
Opening speed settable (ventilation)	●
Additional locking device available	●
Type of additional locking (max.)	2 locking drives
Type of stroke shortening	synchronising unit, factory setting
End position cut-off extended	electronically via internal path sensor
End position cut-off retracted	electric, electronic via current consumption
Overload cut-off	●
Complete opening within 60 s	yes, up to 800 mm stroke, including locking drive
SHEV tested according to EN 12101-2	●
Synchronisation (max.)	4 drives
<b>TYPES OF INSTALLATION</b>	

Bottom-hung window	inward opening outward opening	Frame / leaf Frame
Side-hung window	inward opening outward opening	Frame / leaf Frame
Top-hung window	inward opening outward opening	Frame / leaf Frame
Roof window	outward opening	Frame

● = YES | 1 = The total weight is limited by the hinges and depends on the details provided by the profile system manufacturer. | 2 = Depending on the application and the console set

## PRODUCT SCALE DRAWING

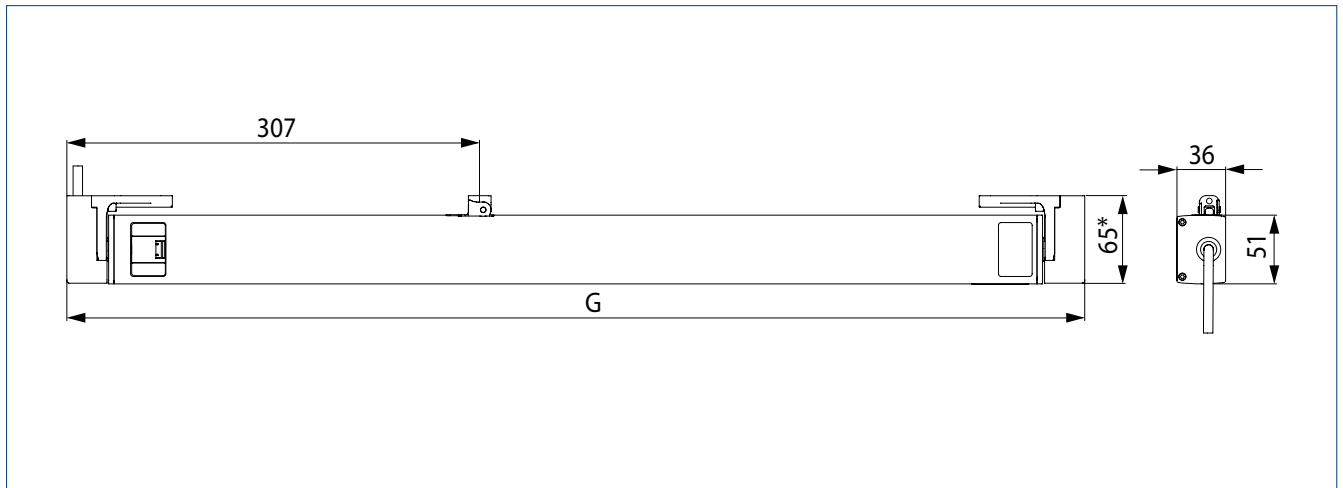

G = Length | \* = Console set A

**TYPES OF INSTALLATION**

Frame installation  
INWARD opening

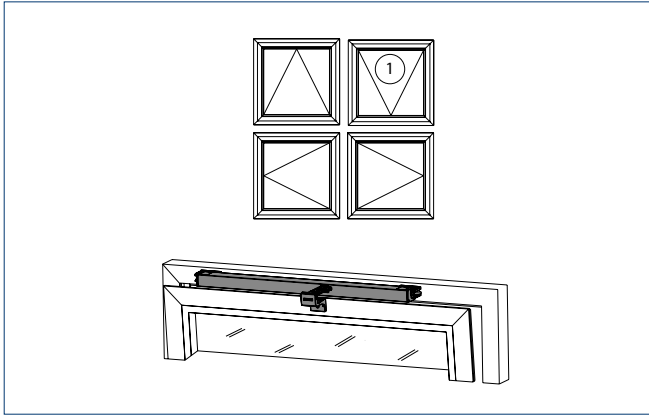

Console set A  
1 = With console set ET

Leaf installation  
INWARD opening

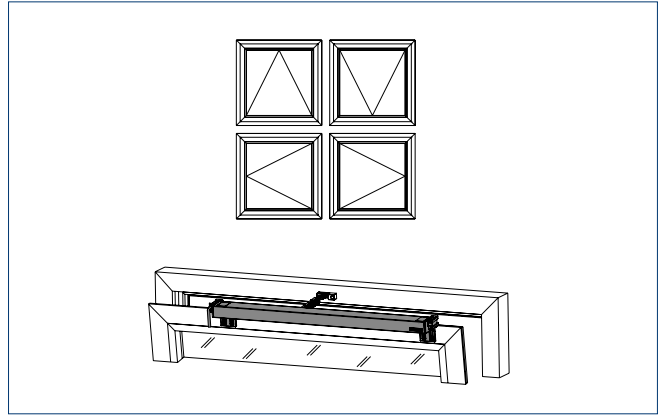

Console set B

Frame installation  
OUTWARD opening

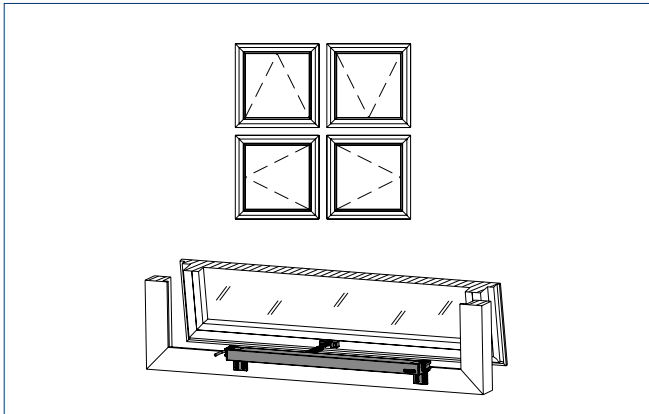

Console set B

Skylight leaf frame installation  
OUTWARD opening



Console set D1, D2 or D3

**FORCE-PATH CHART**

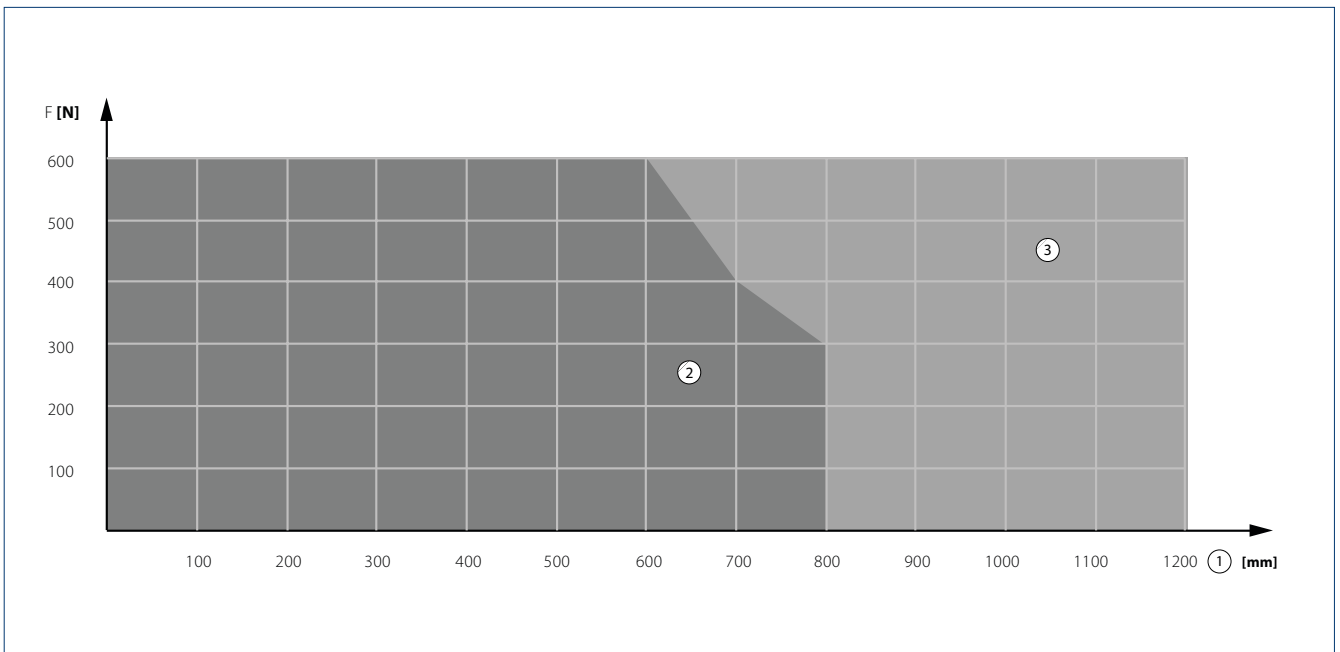

F = Force | 1 = Stroke | 2 = Pressure | 3 = Tension

**AREA OF APPLICATION BOTTOM-HUNG WINDOW FRAME INSTALLATION INWARD OPENING /  
BOTTOM-HUNG WINDOW FRAME INSTALLATION OUTWARD OPENING**

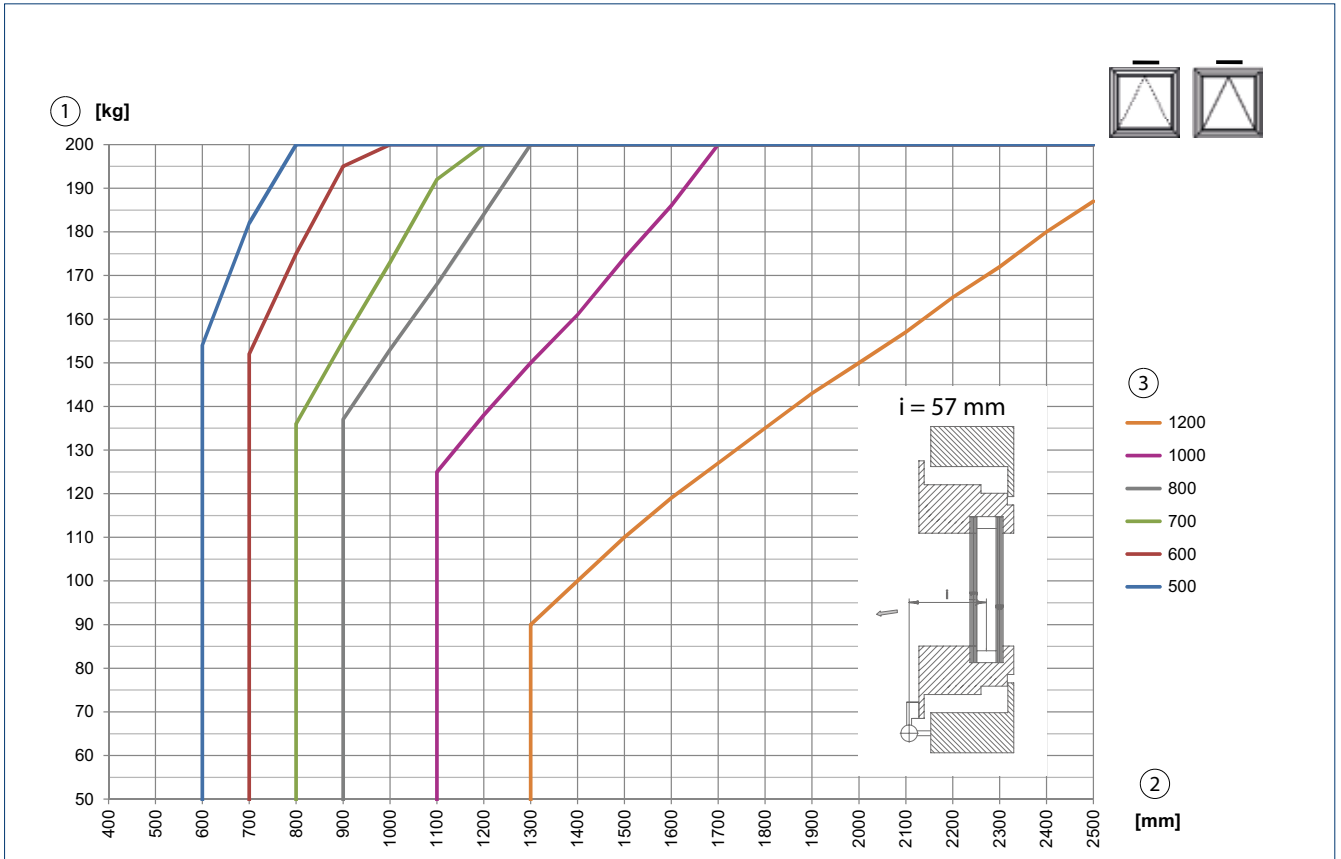

Area of application applies for one Solo drive, for Syncro 2 or Syncro 3 the leaf weight can be doubled or tripled. The details provided by the profile system manufacturer must be heeded. | 1 = Leaf weight | 2 = Secondary closing edge | 3 = Stroke

**AREA OF APPLICATION BOTTOM-HUNG WINDOW LEAF INSTALLATION INWARD OPENING**

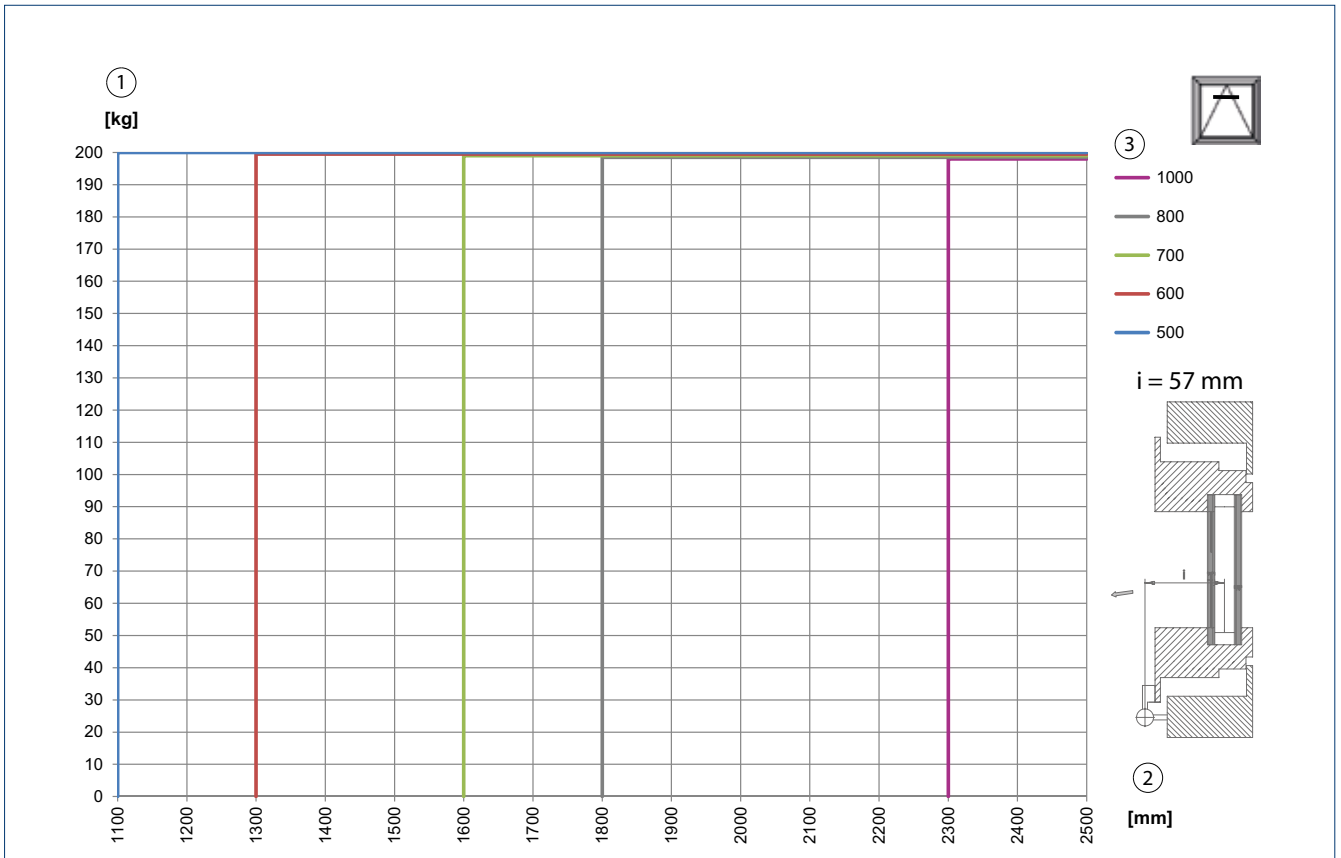

1 = Leaf weight | 2 = Secondary closing edge | 3 = Stroke

**MINIMUM LEAF WIDTH SIDE-HUNG WINDOW FRAME INSTALLATION INWARD OPENING**

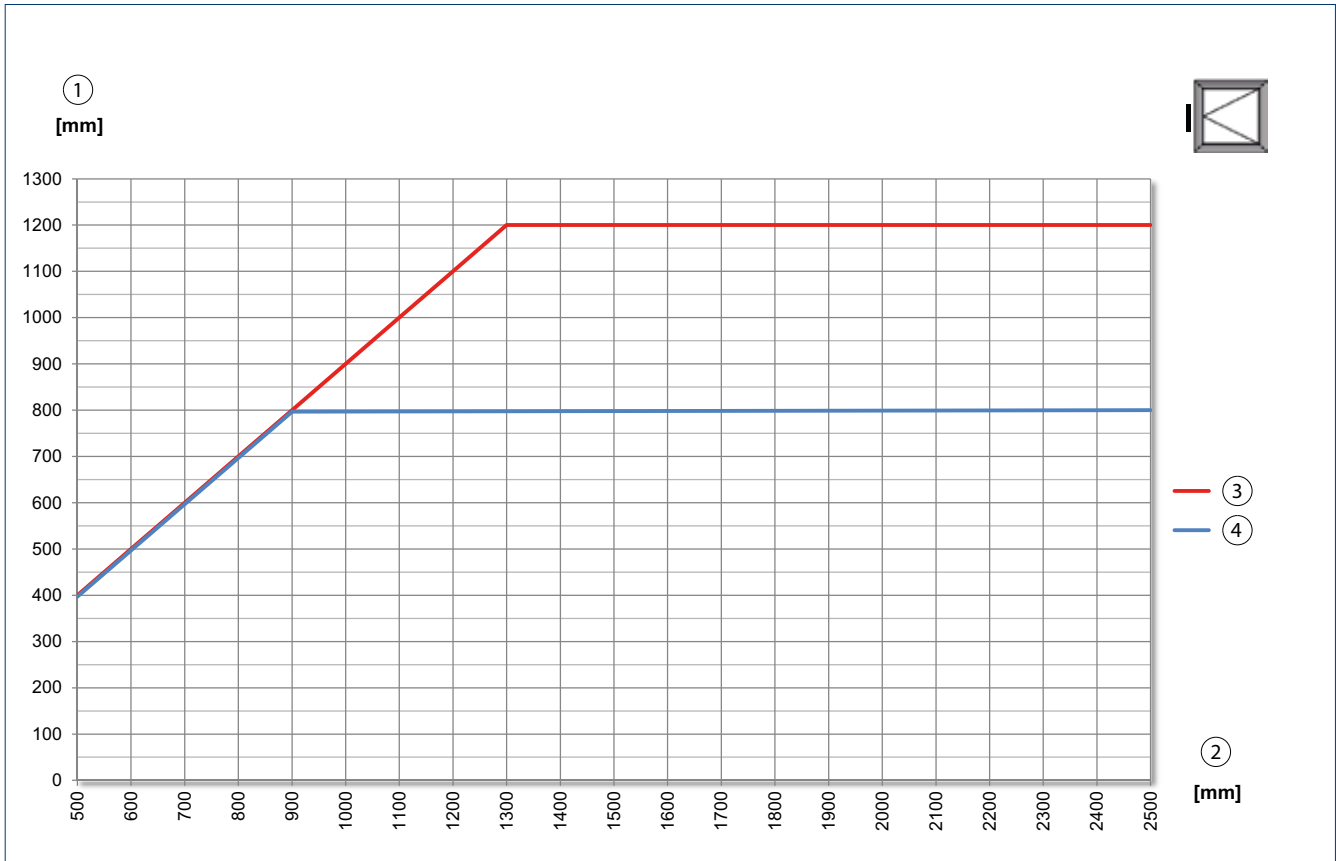

1 = Stroke | 2 = Secondary closing edge | 3 = Alarm | 4 = Ventilation

**MINIMUM LEAF WIDTH SIDE-HUNG WINDOW FRAME INSTALLATION OUTWARD OPENING**

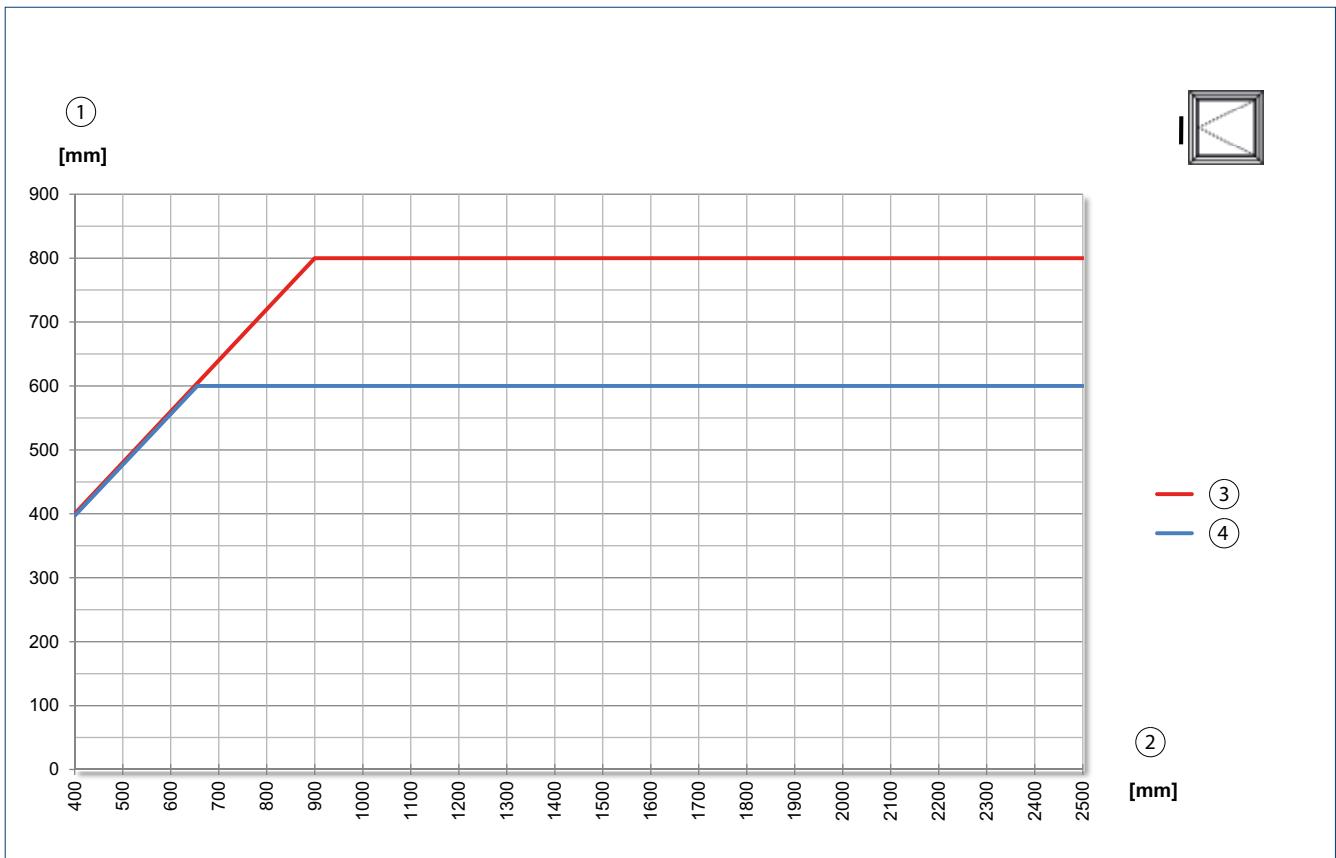

1 = Stroke | 2 = Secondary closing edge | 3 = Alarm | 4 = Ventilation

### MINIMUM LEAF WIDTH SIDE-HUNG WINDOW LEAF INSTALLATION INWARD OPENING

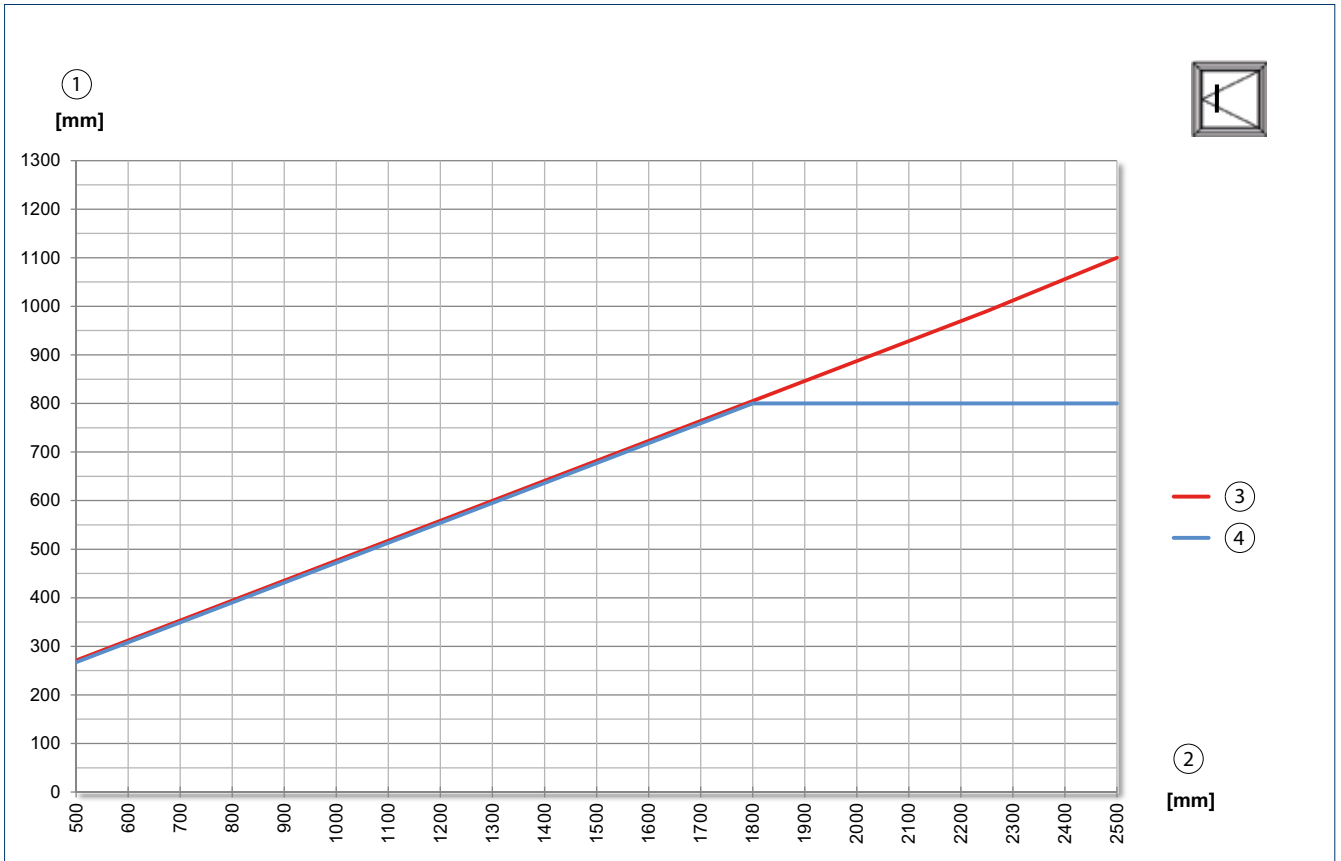

1 = Stroke | 2 = Secondary closing edge | 3 = Alarm | 4 = Ventilation

### AREA OF APPLICATION TOP-HUNG WINDOW FRAME INSTALLATION OUTWARD OPENING

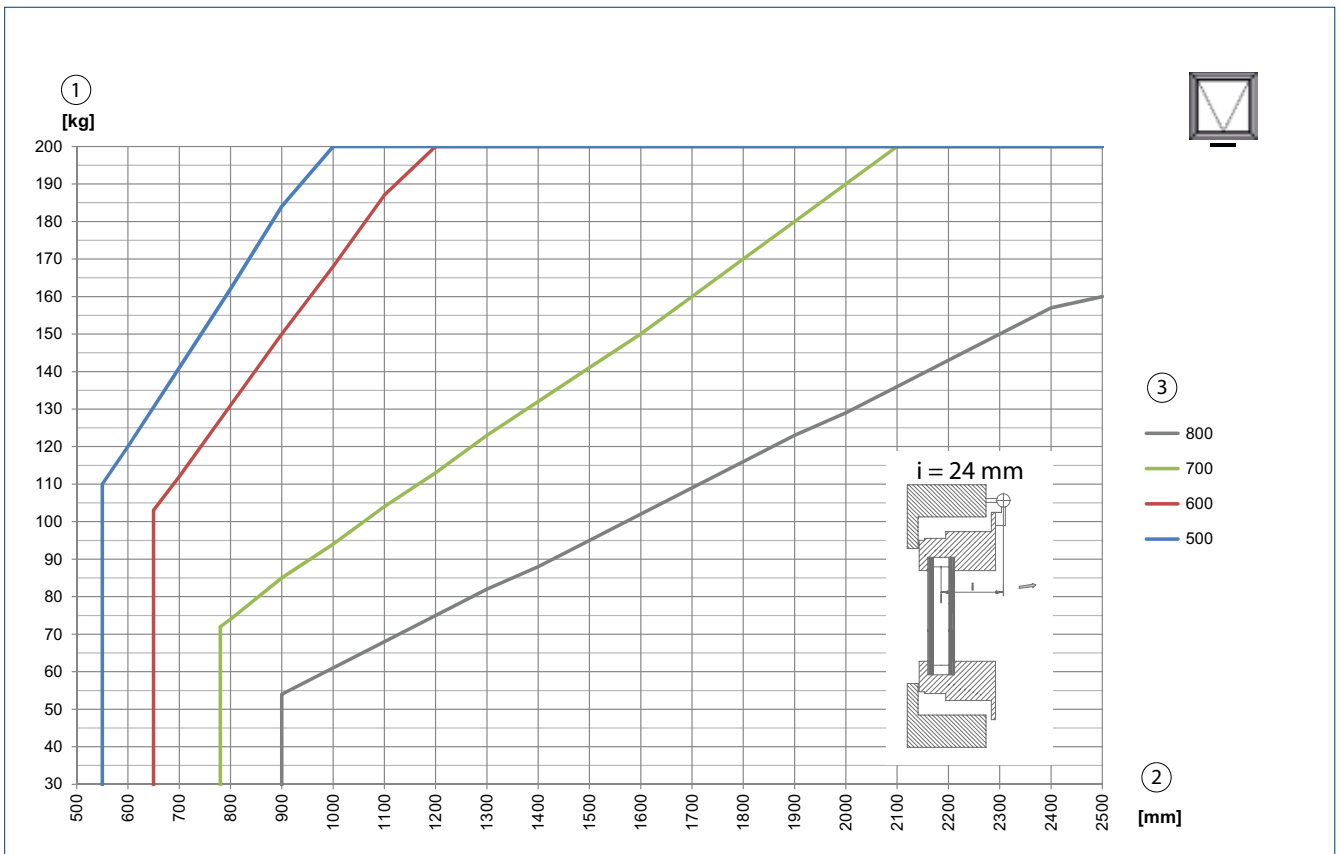

Area of application applies for one Solo drive, for Syncro 2 or Syncro 3 the leaf weight can be doubled or tripled.

The details provided by the profile system manufacturer must be heeded.

1 = Leaf weight | 2 = Secondary closing edge | 3 = Stroke

**MINIMUM LEAF HEIGHT TOP-HUNG WINDOW LEAF INSTALLATION INWARD OPENING**

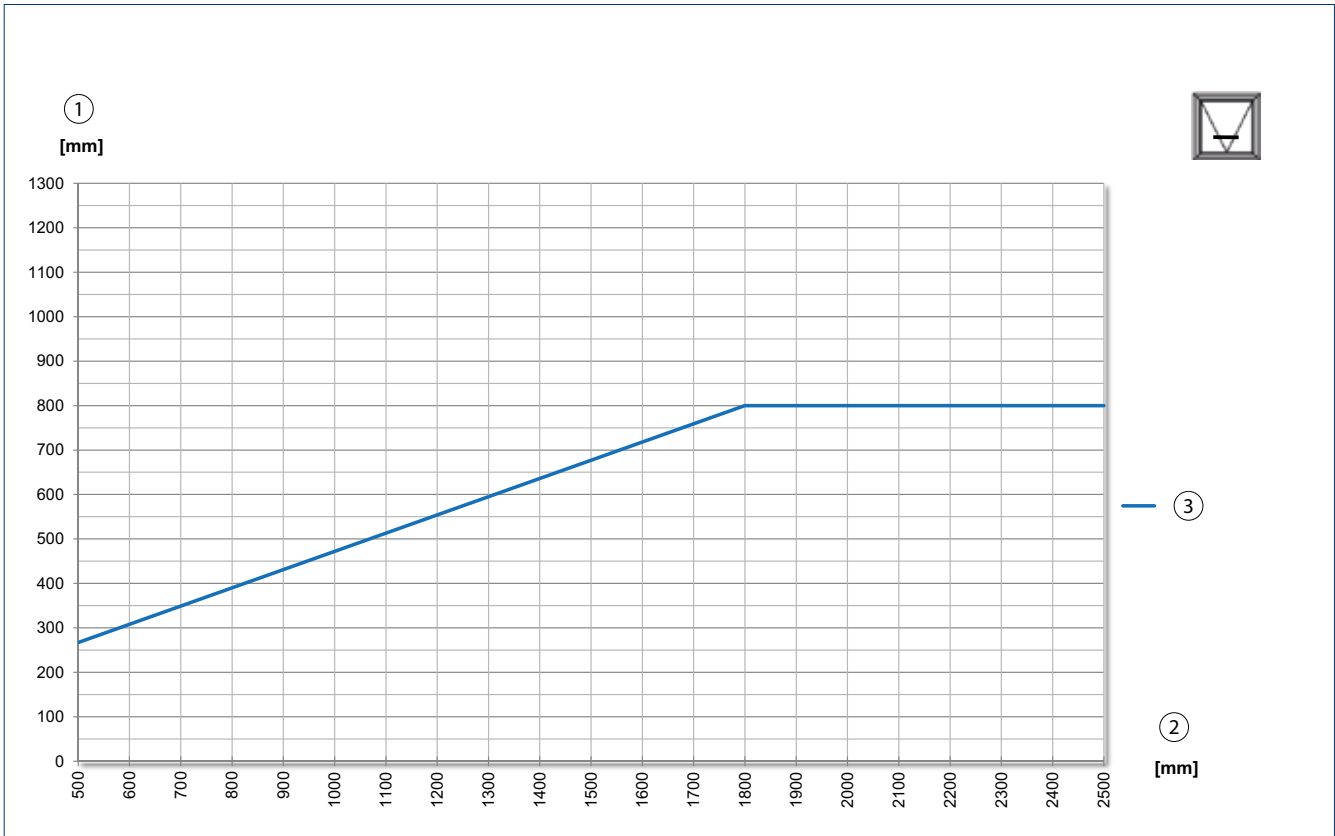

Area of application applies for one Solo drive, for Syncro 2 or Syncro 3 the leaf weight can be doubled or tripled.

The details provided by the profile system manufacturer must be heeded.

1 = Leaf weight | 2 = Secondary closing edge | 3 = Ventilation/alarm



### SPACE NEEDED

Stroke	E [mm]	G [mm]	S [mm]
600	449	756	900
800	549	856	1100
1200	749	1056	1500

### SPACE NEEDED FOR FRAME INSTALLATION INWARD OPENING

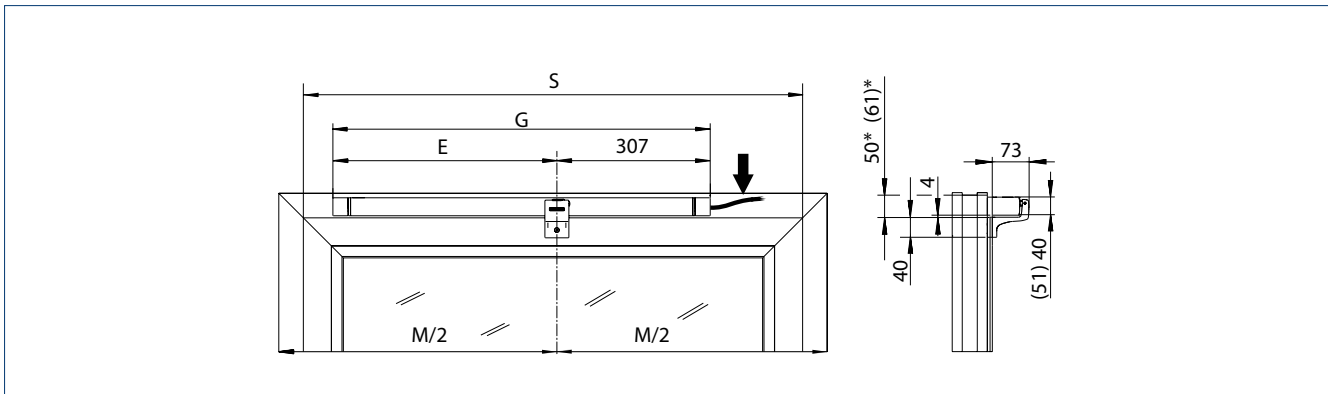

See table for dimensions for E, G and S  
Dimensions in brackets apply for side-hung windows DIN left I\* = Swivelling range

### SPACE NEEDED FOR LEAF INSTALLATION INWARD OPENING

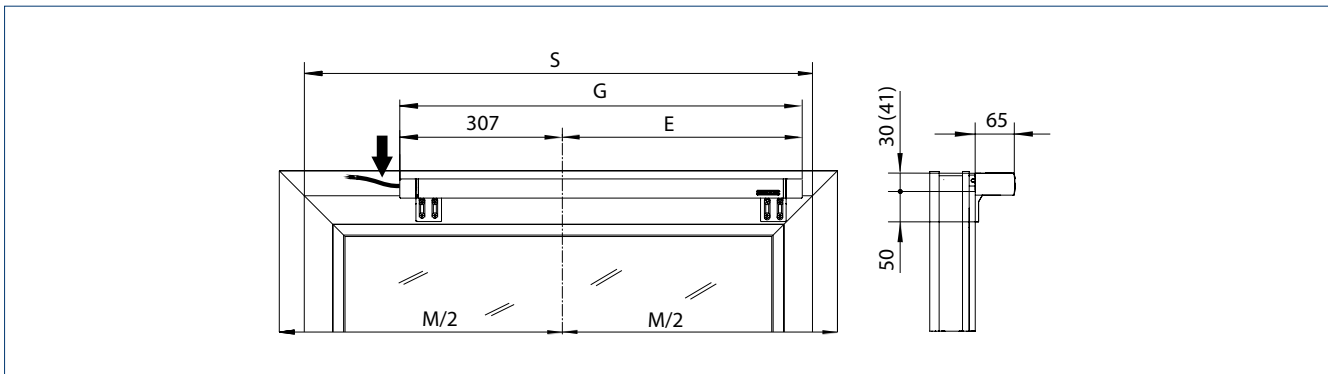

See table for dimensions for E, G and S  
Dimension in brackets applies for side-hung windows DIN right

### SPACE NEEDED FOR FRAME INSTALLATION OUTWARD OPENING

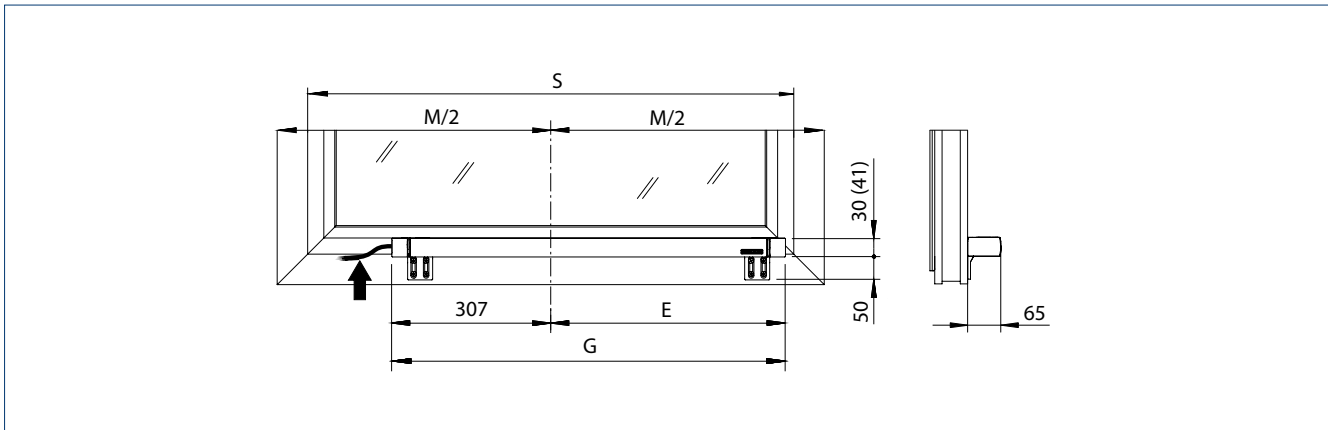

See table for dimensions for E, G and S  
Dimension in brackets applies for side-hung windows DIN right

## SPACE NEEDED - SYNCRO 2

### SPACE NEEDED FOR INSTALLATION WITH TWO DRIVES

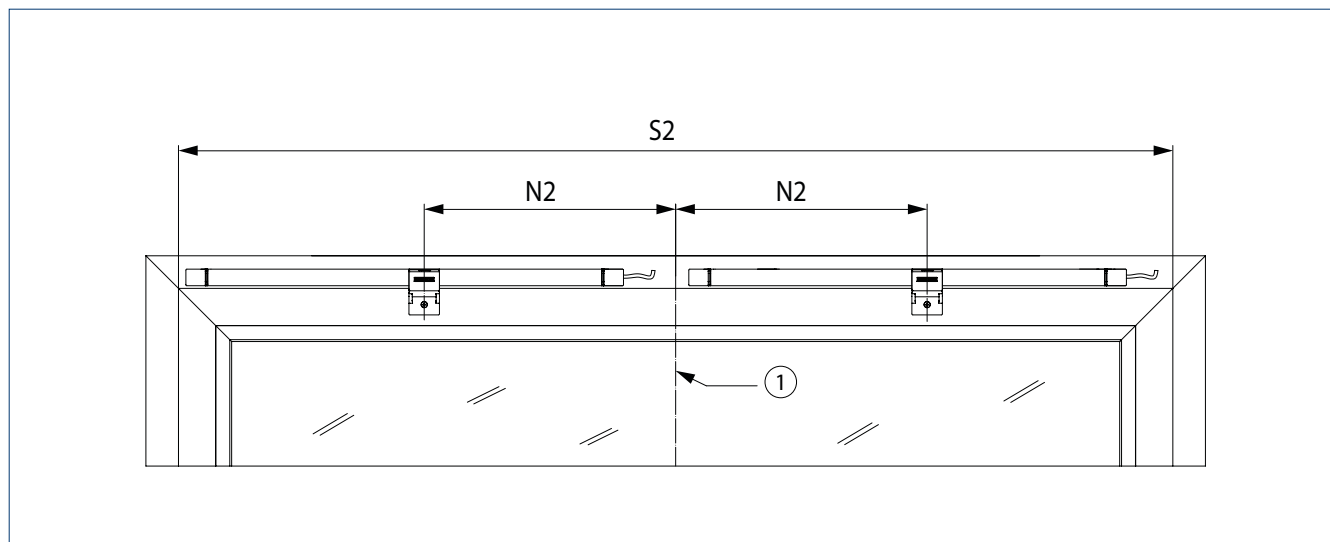

See table for dimensions for S2 and N2  
1 = Centre of window

Stroke	N2 [mm]	S2 [mm]	ID no. EV1/white RAL 9016	Quantity
600	400	1700	147080/147081	2
800	450	2000	147090/147091	2
1200	550	2600	147100/147101	2

## SPACE NEEDED - SYNCRO 3

### SPACE NEEDED FOR INSTALLATION WITH THREE RIGHT-HAND DRIVES

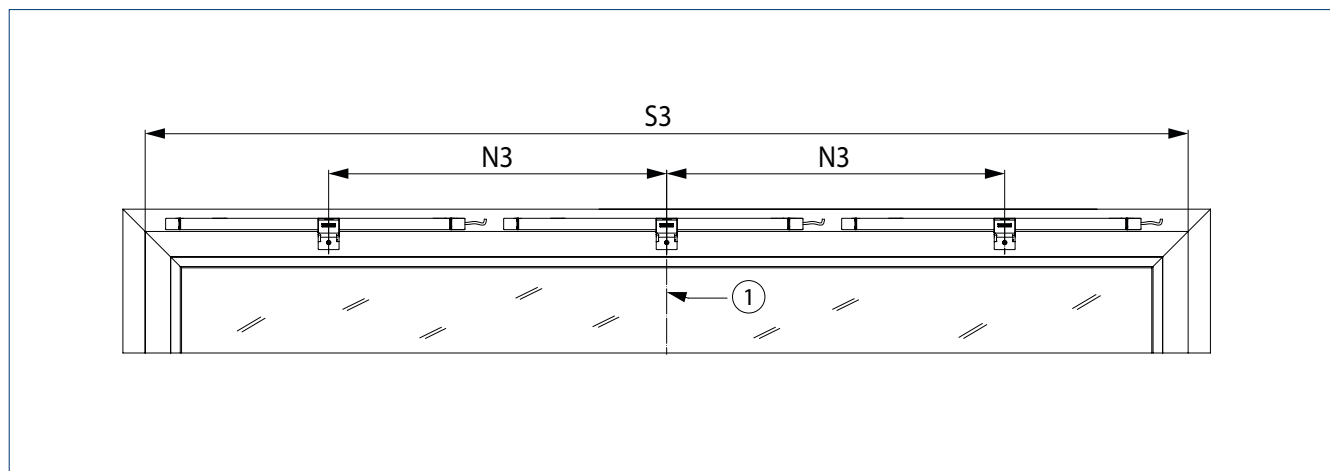

See table for dimensions for S3 and N3  
1 = Centre of window

Stroke	N3 [mm]	S3 [mm]	ID no. EV1/white RAL 9016	Quantity
600	800	2490	147080/147081	3
800	900	2890	147090/147091	3
1200	1100	3690	147100/147101	3

**INSTALLATION DIMENSIONS – RECOMMENDATION**

Frame installation  
INWARD opening

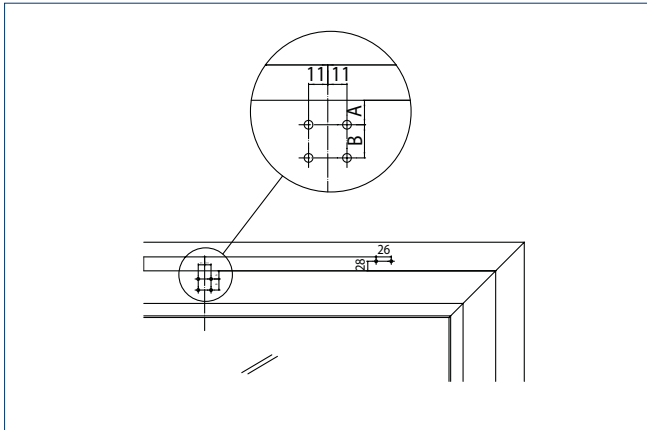

Leaf installation  
INWARD opening

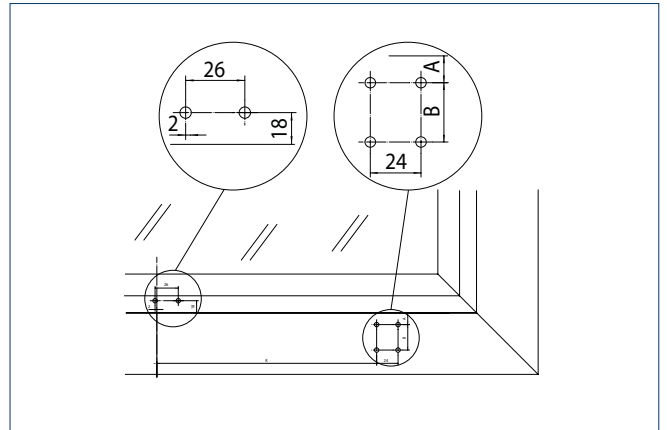

Frame installation  
OUTWARD opening

Material	Manufacturer	Profile system	Frame installation INWARD opening		Leaf installation INWARD opening		Frame installation OUTWARD opening	
			A	B	A	B	A	B
Aluminium	Aluprof	MB-60	14	19	13	22	–	–
		MB-70	14	19	13	22	–	–
	Gutmann	S70	14	19	13	22	–	–
		065	14	19	13	22	16	22
	Heroal	110ES	14	19	13	22	16	22
		Lambda 65	14	19	13	22	15	17
	Hueck	Lambda 77	14	19	13	22	15	17
		Frame+ 65 W	14	19	13	22	14	17
	Raico	Frame+ 75 WB	14	19	13	22	14	17
		1074	14 <sup>1)</sup>	19 <sup>1)</sup>	13 <sup>1)</sup>	20 <sup>1)</sup>	19 <sup>2)</sup>	14 <sup>2)</sup>
	SAPA	1086	14 <sup>3)</sup>	18 <sup>3)</sup>	13 <sup>3)</sup>	19 <sup>3)</sup>	–	–
		AWS 65	14	19	14	22	14	24
	Schueco	AWS 75	14	19	14	22	14	24
		Wicline 65 EVO	14	11	14	22	14	17
Wicon	Wicline 75 EVO	14	11	14	22	14	17	
	EgoKiefer	AS1	17	11	17	23	–	–
Profine		Kömmerring 88plus <sup>4)</sup>	18	14	11	19	–	–
		Alphaline 90	15	18	15	20	–	–
Veka	Softline 82 MD	15	18	15	20	–	–	
	Gutmann	Mira	22	11	22	17	–	–
		Landgraf	IV79	22	11	22	17	–
Oertli	IV68/IV80		22	11	22	17	–	–

All dimensions in mm

1) All profile combinations containing profile number 74102, 74112, 74202 or 74203 allowed

2) All profile combinations containing profile number 74052 allowed

3) All profile combinations containing profile number 86102, 86112 or 86302 allowed

4) On-site supports required, since overlap 24 mm

Further profile ranges on request

## ORDER INFORMATION

Designation	Stroke	ID no.	ID no.
Powerchain	600 mm	EV1	147080
	600 mm	white RAL 9016	147081
	800 mm	EV1	147090
	800 mm	white RAL 9016	147091
	1200 mm	EV1	147100
	1200 mm	white RAL 9016	147101
Powerchain – special version Can be configured: stroke, cable length, colour			147120
<b>ACCESSORIES</b>			
Console set A Powerchain For bottom-hung, side-hung and top-hung windows, frame installation INWARD opening		white RAL 9016 black	147111 147110
Console set B Powerchain For bottom-hung, side-hung and top-hung windows, leaf installation INWARD opening and frame installation OUTWARD opening Roof profile system: Aluprof MB-SR 50, Reynaers CW 50, Raico Wing 105 DI		white RAL 9016 black	147113 147112
Choice of consoles for Powerchain Can be configured: Type of opening, opening direction, installation type, colour		according to RAL	147121
Bracket set roof D1 For roof window frame installation OUTWARD opening. For roof profile systems: Heroal C50, Hueck 85E, Wicona Wictec 50-60		black	154869
Bracket set roof D2 For roof window frame installation OUTWARD opening. For roof profile systems: Akotherm AT 500F, Alcoa AA100, Heroal 180, Hueck VF50, MGlass		silver	154870
Bracket set roof D3 For roof window frame installation OUTWARD opening. For roof profile systems: Schüco AWS 57RO		silver	158053
Choice of consoles roof Can be configured: Profile system, colour		according to RAL	159901
Console set ET For top-hung window frame installation Inward opening		white black	161139 161140

# Console sets



Console set A Powerchain  
(147110)



Console set B Powerchain  
(147112)



Console set roof D1 (154869)



Console set roof D2 (154870)



Console set roof D3 (158053)



Console set ET (161140)

# E 250 NT



**Compact design spindle drive  
with a wide area of application**

## AREAS OF APPLICATION

- Smoke and heat extraction system and natural ventilation (24 V) for direct opening in the façade and roof area
- Inward and outward opening windows with bottom-, top- and side-hung leaves
- Louvre and roof windows
- Can be used in the exhaust air and air intake
- Protected outdoor area (e.g. conservatories) with variant E 250 NT AB
- Installation on wooden, PVC or metal windows

## PRODUCT FEATURES

- Continuously adjustable drive stroke and individual speeds for ventilation and smoke and heat extraction
- Synchronisation of max. four drives without external control unit
- Easy change of the mode of operation (Solo and Syncro, master/slave) via DIP switch
- IQ windowdrive - intelligent drive control
- SHEV tested according to EN 12101-2

## TECHNICAL DATA

## E 250 NT

## GENERAL INFORMATION

Dimensions (W x H x D)	stroke + 284 x 40 x 47 mm
------------------------	---------------------------

## SPECIFICATIONS

Possible stroke lengths	100 mm, 150 mm, 200 mm, 230 mm, 300 mm, 500 mm, 750 mm, 1000 mm
Opening speed smoke and heat extraction	5.7 mm/s, stroke 500: 9.5 mm/s
Opening speed ventilation	5 mm/s
Tensile force (max.)	750 N
Compressive force (max.)	750 N
Holding force (max.)	2000 N

## ELECTRICAL DATA

Operating voltage	24 V DC
Current consumption	ventilation (24 V): 0.9 A; smoke and heat extraction (18 V): 1.0 A stroke 500: Ventilation (24 V): 1.1 A; smoke and heat extraction (18 V): 1.3 A
Power consumption (max.)	20 W
Duty rating	30 %
Length of power supply cable	2 m
Special length of power supply cable	5 m, 7.5 m
Cable dimensions	4 x 0.75 mm <sup>2</sup>
Temperature range	-5 – 70 °C
IP rating / protection rating	IP65 / III

## FUNCTIONS

Stroke length settable	●
Syncro function	●
Opening speed settable (ventilation)	●
Additional locking device available	●
Type of additional locking (max.)	2 locking drives
Type of stroke shortening	factory setting, synchronising unit
End position cut-off extended	electronically via distance and load
End position cut-off retracted	electronically via distance and load
Overload cut-off	●
Complete opening within 60 s	yes, up to 500 mm stroke
SHEV tested according to EN 12101-2	yes, up to 500 mm stroke
Synchronisation (max.)	4 drives

## TYPES OF INSTALLATION

Bottom-hung window	inward opening	frame / leaf frame
	outward opening	
Side-hung window	inward opening	frame / leaf frame
	outward opening	
Top-hung window	inward opening	frame / leaf frame
	outward opening	
Roof window	outward opening	frame
Louvre window		frame

● = YES

## PRODUCT SCALE DRAWING

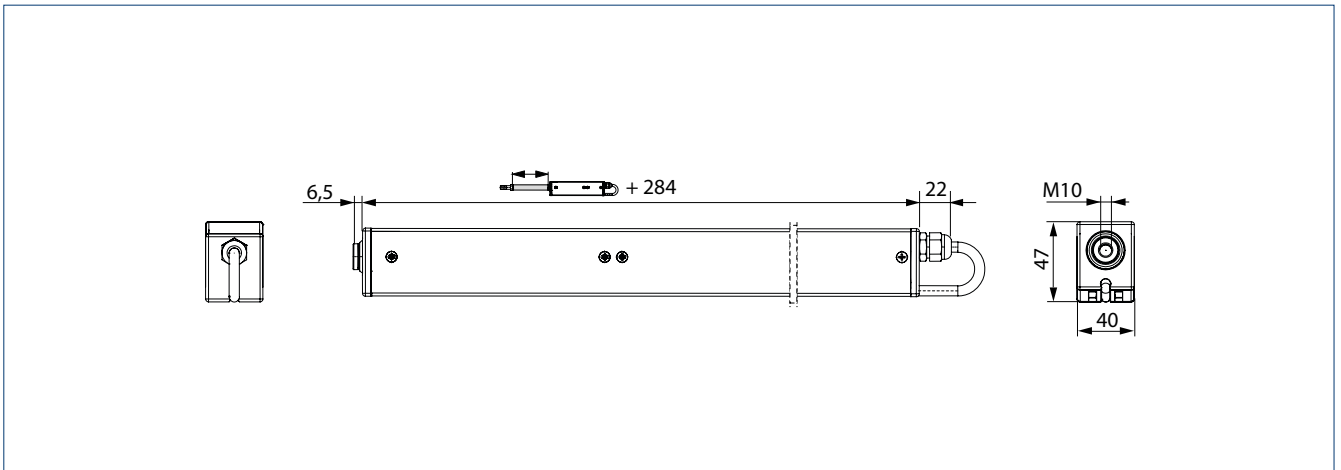

## TYPES OF INSTALLATION

Roof windows and skylight domes  
OUTWARD opening

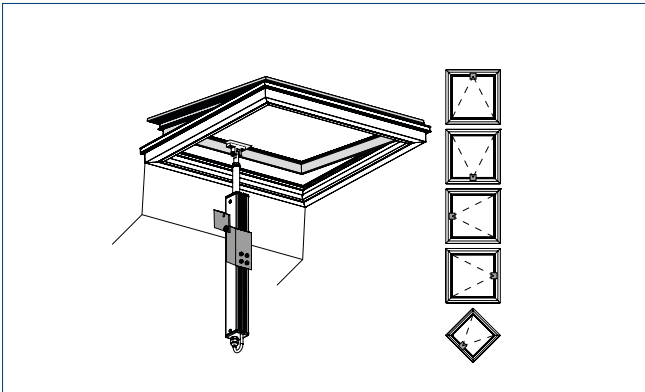

Standard console for installation on the lintel of the main closing edge

Bottom-hung, top-hung, side-hung and roof windows  
INWARD or OUTWARD opening

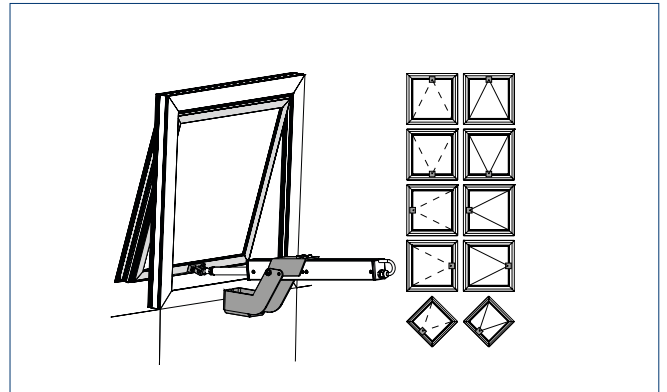

INWARD opening console for installation on frame of the main closing edge

Roof windows and skylight domes  
OUTWARD opening

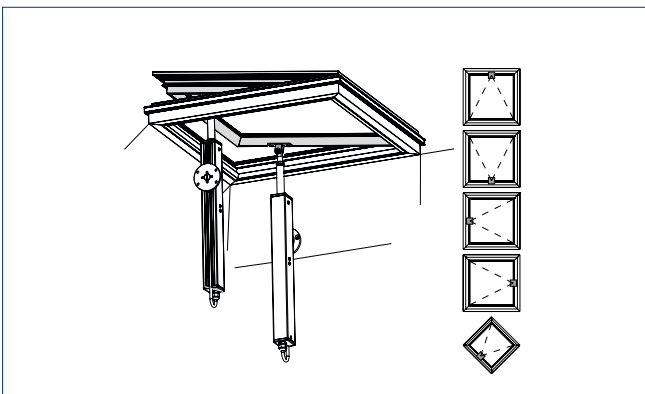

Swivelling console for installation on the lintel of the secondary closing edge

## INSTALLATION

### MINIMUM LEAF HEIGHTS FOR INWARD OPENING BOTTOM-, TOP- AND SIDE-HUNG WINDOWS

Stroke	Leaf height
100 mm	–
150 mm	–
200 mm	200 mm
230 mm	230 mm
300 mm	300 mm
500 mm	600 mm

### MINIMUM LEAF HEIGHTS FOR OUTWARD OPENING BOTTOM-, TOP- AND SIDE-HUNG WINDOWS

Stroke	Leaf height
100 – 300 mm	400 mm
500 mm	600 mm

### MINIMUM LEAF HEIGHTS FOR ROOF WINDOWS AND SKYLIGHT DOMES

Stroke	Leaf height
100 mm	220 mm
150 mm	270 mm
200 mm	320 mm
230 mm	350 mm
300 mm	440 mm
500 mm	670 mm
700 mm	910 mm
750 mm	980 mm
1000 mm	1270 mm

### SOLO APPLICATION AT THE MAIN CLOSING EDGE

Leaf weight max. 100 kg, leaf width < 1200 mm

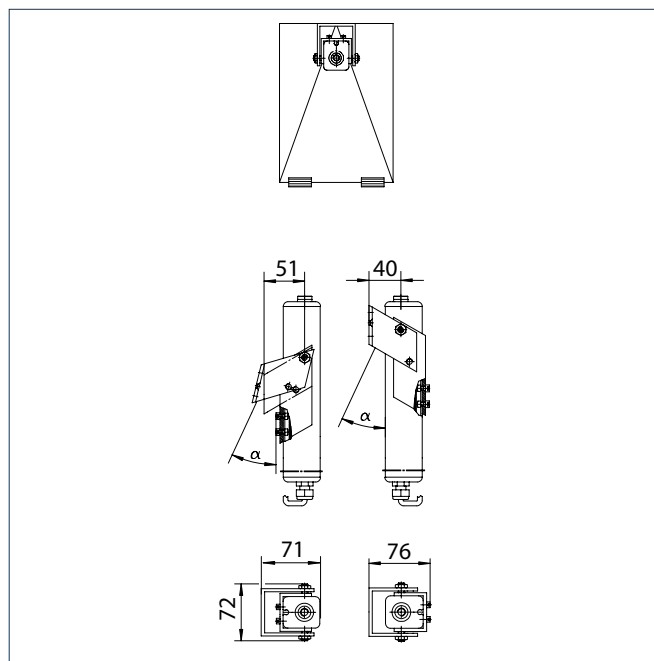

Standard console

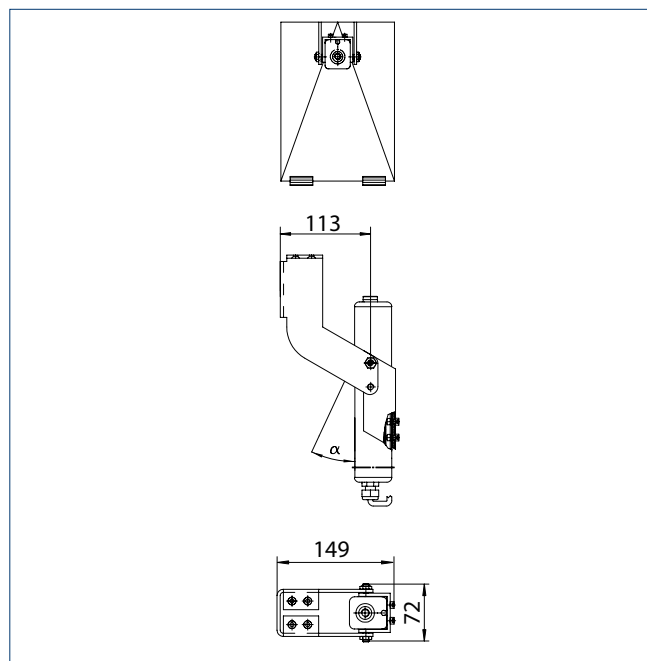

INWARD opening console



## INSTALLATION - SYNCRO 2

### SYNCRO APPLICATION AT THE MAIN CLOSING EDGE

Leaf weight max. 200 kg, leaf width < 2400 mm

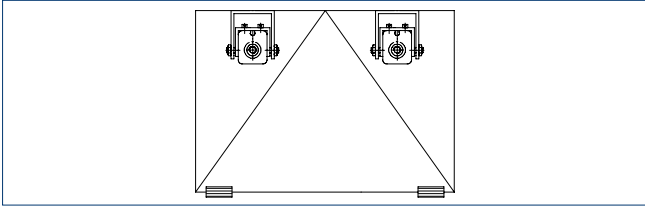

Standard console

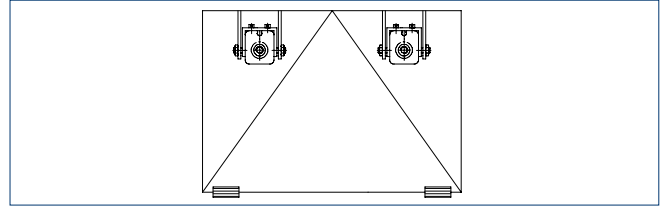

Inward opening console

### SYNCRO APPLICATION AT THE SECONDARY CLOSING EDGE

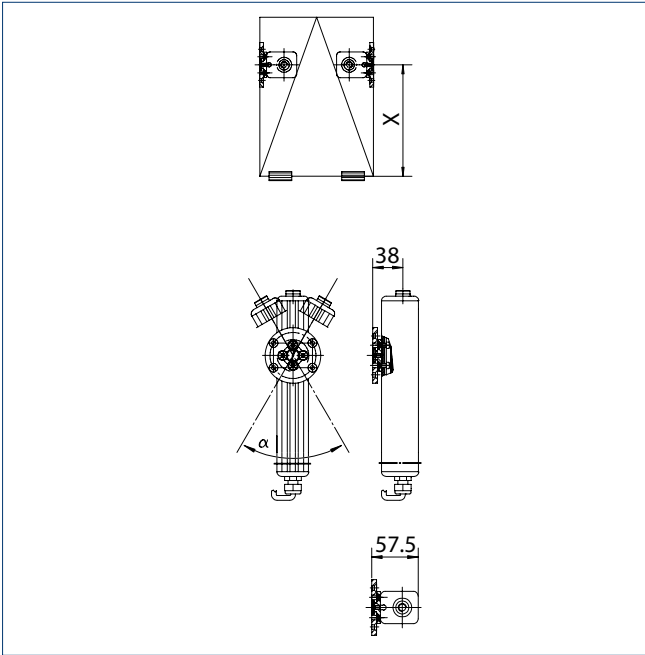

Swivelling console

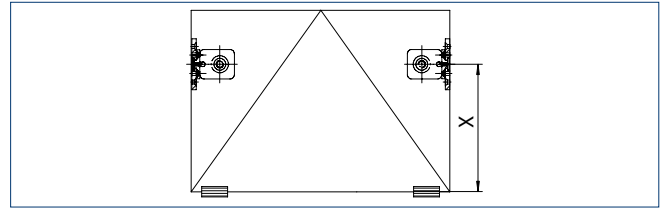

Swivelling console

### DETERMINING THE OPENING ANGLE USING THE SWIVELLING CONSOLE

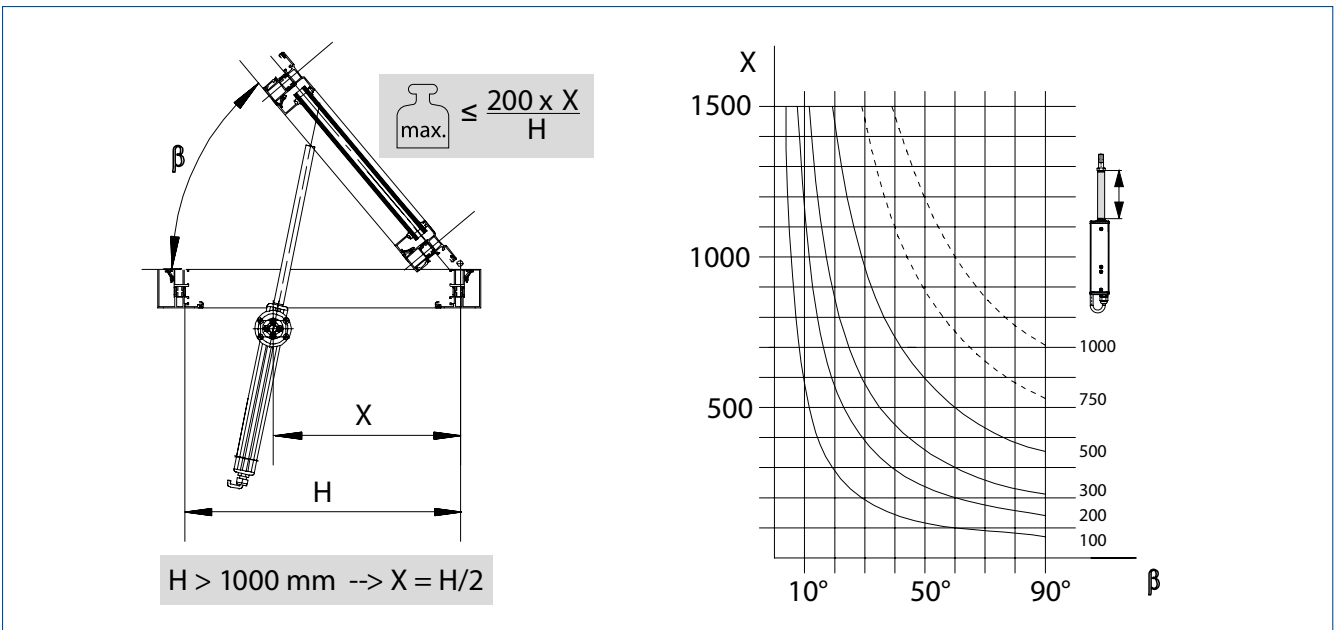

H = Secondary closing edge | X = Fitting dimension |  $\beta$  = Opening angle

**PROFILE-SPECIFIC INSTALLATION**

**WICONA WICTEC 50/60**

Installation on main closing edge

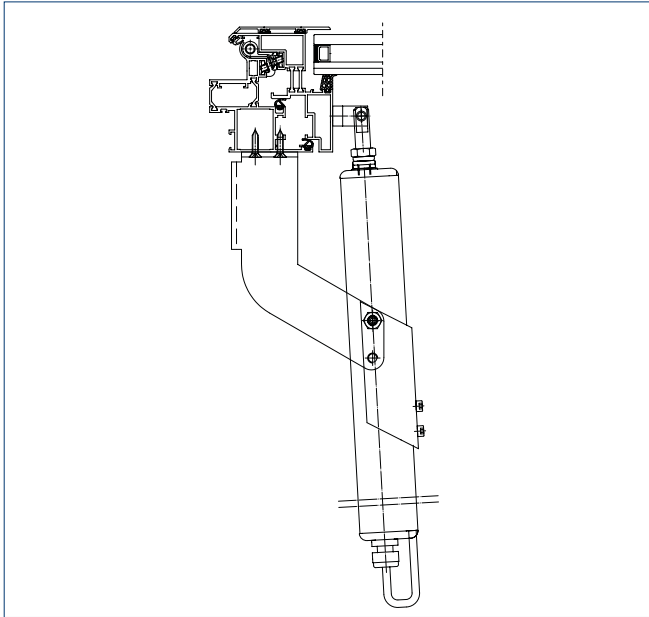

Console INWARD opening E 250 NT / 350 N, incl. standard leaf bracket (ID no. 027218)

**WICONA WICTEC 50/60**

Installation on secondary closing edge

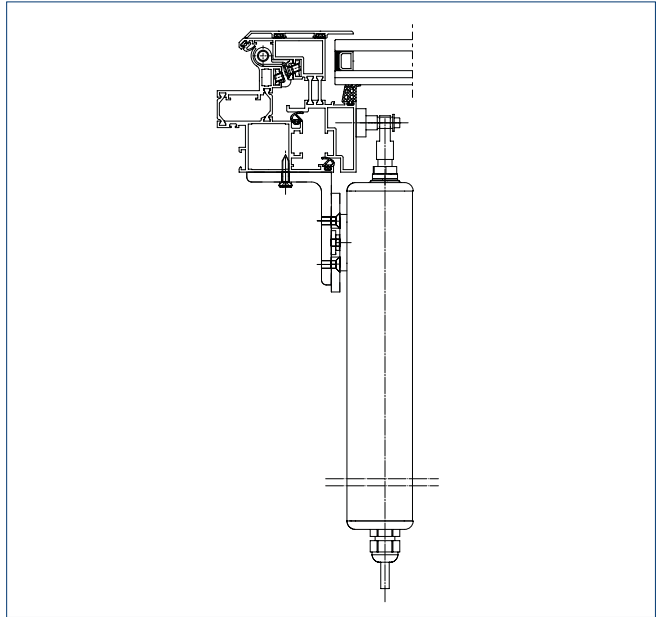

Leaf bracket E 1500 NSK W-HU (ID no. 136187) | Swivelling console E 250 NSK / E 350 N, incl. console bracket E 250 and eye bolt  $\varnothing$  8 mm (ID no. 138367)

**SCHÜCO AWS57**

Installation on main closing edge

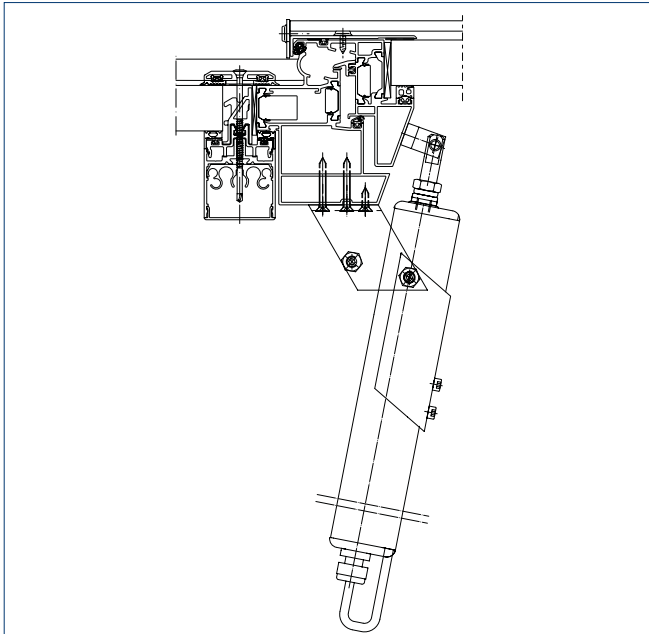

Standard console E 250 NT / E 350 N, incl. standard leaf bracket (ID no. 019032)

**SCHÜCO AWS57**

Installation on secondary closing edge

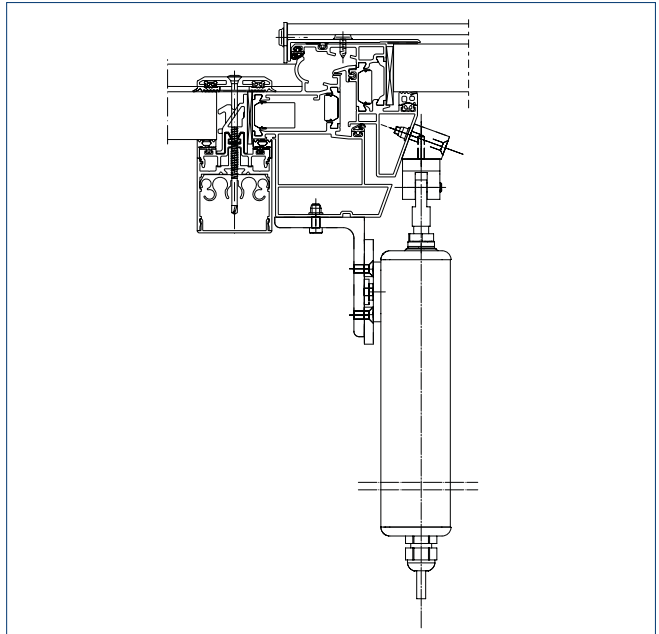

Adapter for console E 250 NSK S (ID no. 138370) | Swivelling console E 250 NT + E 350 N (ID no. 116112) | Bracket E 250 NSK (ID no. 138369)

For further profile-specific solutions for Heroal, Alcoa, Hueck and Aluprof see installation diagram 45130-EP-002.

## ORDER INFORMATION

Designation	Stroke	ID no.	ID no.
E 250 NT	100 mm	EV1	146499
	100 mm	white RAL 9016	146500
	100 mm	according to RAL	146651
	150 mm	EV1	146652
	150 mm	white RAL 9016	146653
	150 mm	according to RAL	146654
	200 mm	EV1	146655
	200 mm	white RAL 9016	146656
	200 mm	according to RAL	146657
	230 mm	EV1	146658
	230 mm	white RAL 9016	146659
	230 mm	according to RAL	146660
	300 mm	EV1	146661
	300 mm	white RAL 9016	146662
	300 mm	according to RAL	146663
	500 mm	EV1	146664
	500 mm	white RAL 9016	146665
	500 mm	according to RAL	146666
	750 mm	EV1	146670
	750 mm	white RAL 9016	146671
750 mm	according to RAL	146672	
1000 mm	EV1	146673	
1000 mm	white RAL 9016	146674	
1000 mm	according to RAL	146675	
E 250 NT – special version Can be configured: stroke, cable length, colour, variant E 250 NT AB			146676
<b>ACCESSORIES</b>			
Swivelling console E 250 NSK with eye bolt and console bracket suitable for installation on the secondary closing edge of roof windows			138367
Swivelling console E 250 NT with eye bolts and leaf bracket	EV1		116112
	white RAL 9016		116113
	according to RAL		116114
Console INWARD opening E 250 NT with eye bolts and leaf bracket	EV1		027218
	white RAL 9016		027223
	according to RAL		027222
Standard console E 250 NT with eye bolts and leaf bracket	EV1		019032
	white RAL 9016		020879
	according to RAL		020878
Adapter for console E 250 NT NSK-S suitable for installation on the secondary closing edge of roof windows (Schüco AWS57 RO)			138370
Eye bolt E 250 NT DRM suitable for installation on the secondary closing edge of roof windows			138368
Bracket E 250 NT NSK suitable for installation on the secondary closing edge of roof windows			138369
Leaf bracket E 1500 HSK HE suitable for installation on the main closing edge of roof windows (Heroal), can also be used for E 250 NT			136190
Leaf bracket E 1500 NSK A-HU suitable for installation on the secondary closing edge of roof windows (Alcoa AA 100, Hueck VF 50/60), can also be used for E 250 NT			136189
Leaf bracket E 1500 NSK HE suitable for installation on the secondary closing edge of roof windows (Heroal 85 D), also suitable for E 250 NT			136188
Leaf bracket E 1500 NSK W-HU suitable for installation on the secondary closing edge of roof windows (Wicona WT 50/60, Hueck 85 E), can also be used for E 250 NT			136187
Leaf bracket E 1500/ E 3000 NSK AP suitable for installation on the secondary closing edge of roof windows (Aluprof MB- SR50), can also be used for E 250 NT			140713

# Accessories



**Swivelling console E 250 NT**  
(116112)



**Console INWARD opening  
E 250 NT** (027218)



**Standard console E 250 NT**  
(019032)

# E 350 N



Spindle drive in 230 V version  
with extensive console program

## AREAS OF APPLICATION

- Direct opener for natural ventilation (230 V) in the façade and roof area
- Inward and outward opening windows with bottom-, top- and side-hung leaves
- Louvre and roof windows
- Installation on wooden, PVC or metal windows

## PRODUCT FEATURES

- Compact design
- Versatile thanks to extensive console range
- Robust design with mechanical load cut-off and IP rating IP65

**TECHNICAL DATA**

**E 350 N**

**SPECIFICATIONS**

Possible stroke lengths	100 mm, 150 mm, 200 mm, 230 mm, 300 mm, 500 mm, 700 mm, 750 mm, 1000 mm
Opening speed ventilation	5 mm/s
Tensile force (max.)	750 N
Compressive force (max.)	750 N
Holding force (max.)	2000 N

**ELECTRICAL DATA**

Operating voltage	230V AC
Current consumption	0.15 A
Power consumption (max.)	35 W
Duty rating	50 %
Length of power supply cable	2.5 m
Cable dimensions	3 x 0.75 mm <sup>2</sup>
Temperature range	-20 – 70 ° C
IP rating/protection rating	IP65 / II

**FUNCTIONS**

End position cut-off extended	mechanical overload cut-off
End position cut-off retracted	mechanical overload cut-off
Overload cut-off	●

**TYPES OF INSTALLATION**

Bottom-hung window	inward opening outward opening	frame / leaf frame
Side-hung window	inward opening outward opening	frame / leaf frame
Top-hung window	inward opening outward opening	frame / leaf frame
Roof window	outward opening	frame
Louvre window		frame

● = YES

**PRODUCT SCALE DRAWING**

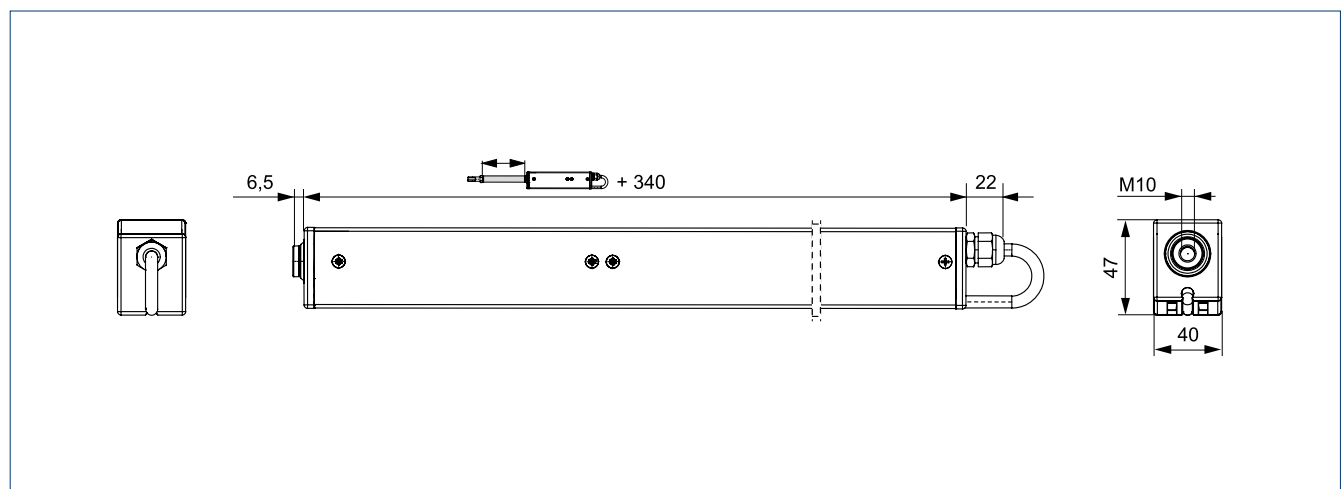

## TYPES OF INSTALLATION

Roof windows and skylight domes  
OUTWARD opening

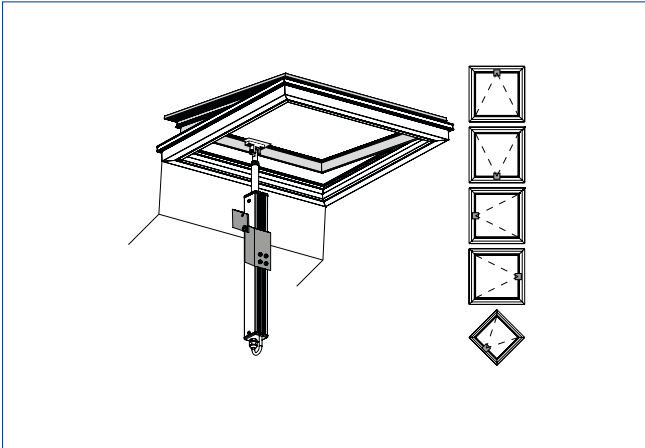

Standard console for installation on the lintel of the main closing edge

Bottom-hung, top-hung, side-hung and roof windows  
INWARD or OUTWARD opening

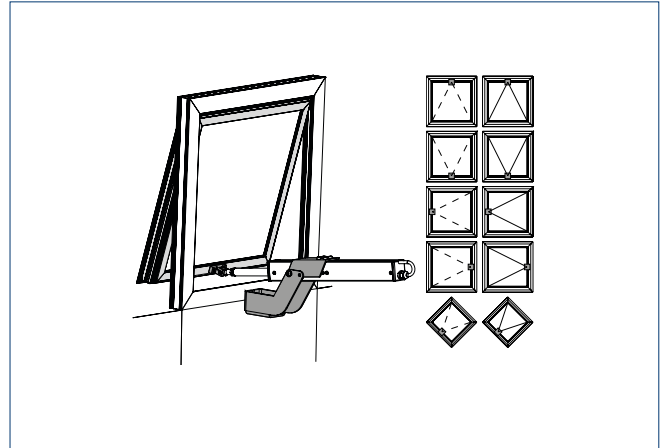

INWARD opening console for installation on the frame or main closing edge

## INSTALLATION

### MINIMUM LEAF HEIGHTS FOR INWARD OPENING BOTTOM-, TOP- AND SIDE-HUNG WINDOWS

Stroke	Leaf height
100 mm	–
150 mm	–
200 mm	200 mm
230 mm	230 mm
300 mm	300 mm
500 mm	600 mm

### MINIMUM LEAF HEIGHTS FOR OUTWARD OPENING BOTTOM-, TOP- AND SIDE-HUNG WINDOWS

Stroke	Leaf height
100 – 300 mm	400 mm
500 mm	600 mm

### MINIMUM LEAF HEIGHTS FOR ROOF WINDOWS AND SKYLIGHT DOMES

Stroke	Leaf height
100 mm	220 mm
150 mm	270 mm
200 mm	320 mm
230 mm	350 mm
300 mm	440 mm
500 mm	670 mm
700 mm	910 mm
750 mm	980 mm
1000 mm	1270 mm

SOLO APPLICATION ON THE MAIN CLOSING EDGE

Leaf weight max. 100 kg, leaf width < 1200 mm

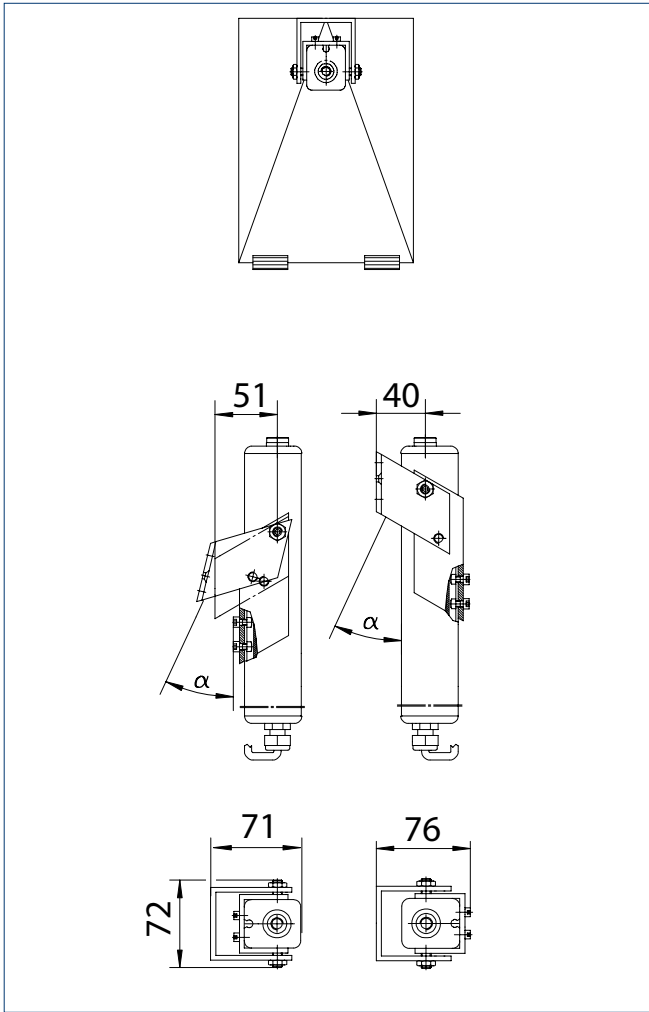

Standard console

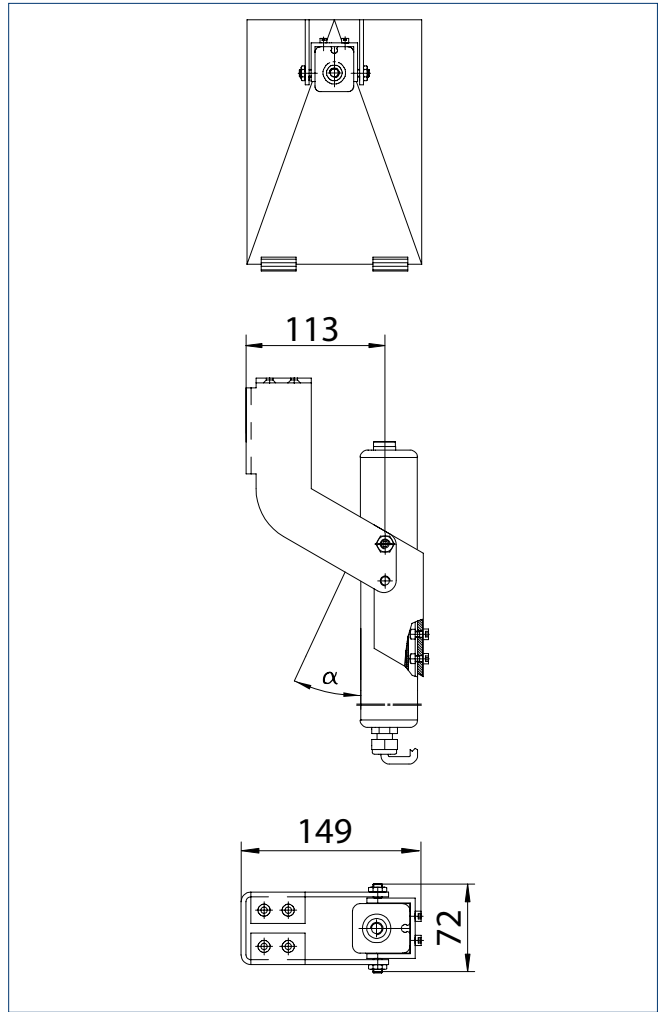

INWARD opening console



## PROFILE-SPECIFIC INSTALLATION

### WICONA WICTEC 50/60

Installation on main closing edge

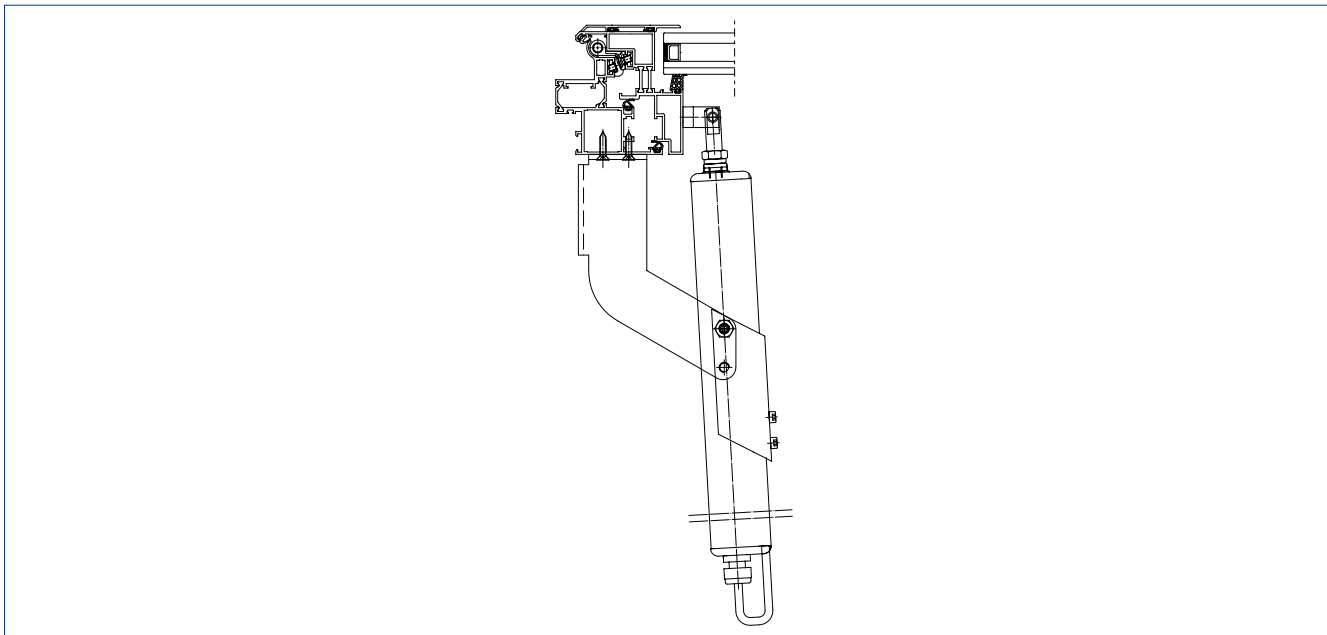

Console INWARD opening E 250 NT / E 350 N, incl. standard leaf bracket (ID no. 027218)

### SCHÜCO AWS57

Installation on main closing edge

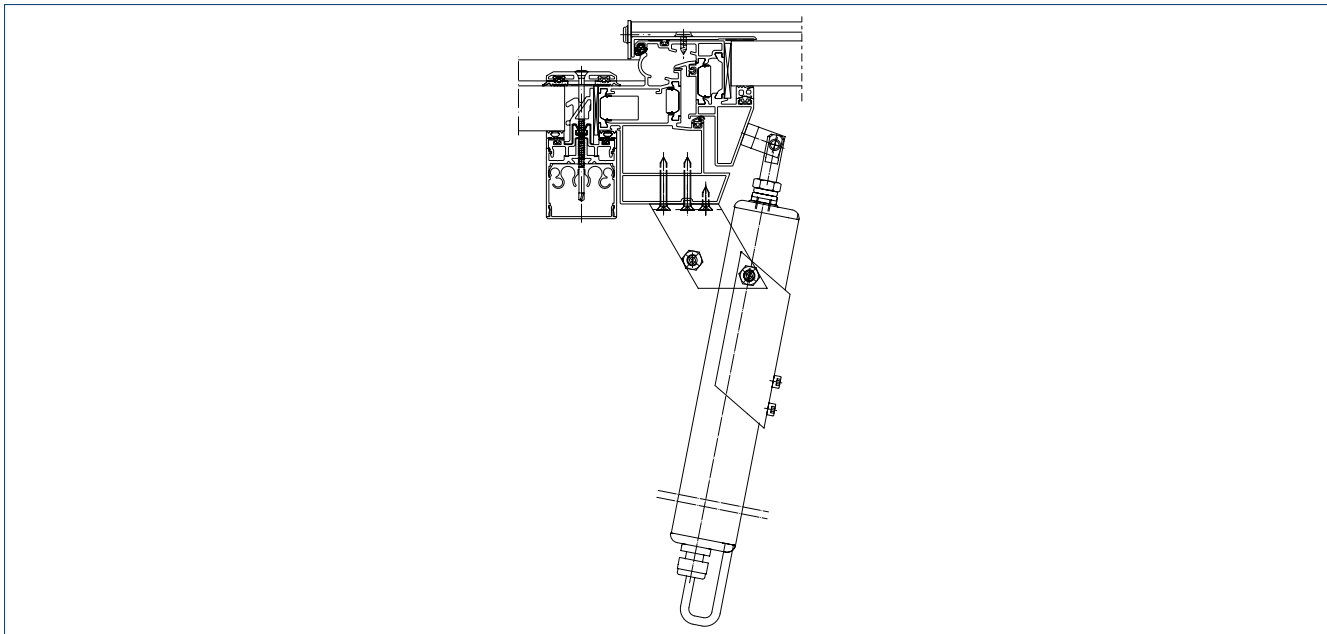

Standard console E 250 NT / E 350 N, incl. standard leaf bracket (ID no. 019032)

For further profile-specific solutions on the main closing edge for Heroal, Alcoa, Hueck and Aluprof see installation diagram 45130-EP-002.

## ORDER INFORMATION

Designation	Stroke	Version	ID no.
E 350 N	100 mm	EV1	086121
	100 mm	white RAL 9016	086124
	150 mm	EV1	086126
	150 mm	white RAL 9016	086129
	200 mm	EV1	086131
	200 mm	white RAL 9016	086134
	230 mm	EV1	086136
	230 mm	white RAL 9016	086139
	300 mm	EV1	086141
	300 mm	white RAL 9016	086144
	500 mm	EV1	086146
	500 mm	white RAL 9016	086149
	700 mm	EV1	086151
	700 mm	white RAL 9016	086154
	750 mm	EV1	086156
	750 mm	white RAL 9016	086159
	1000 mm	EV1	086161
1000 mm	white RAL 9016	086164	

## ACCESSORIES

Standard console E 250 NT / E 350 N with eye bolts and leaf bracket	EV1	019032
	white RAL 9016	020879
	according to RAL	020878
Console INWARD opening E 250 NT / E 350 N with eye bolts and leaf bracket	EV1	027218
	white RAL 9016	027223
	according to RAL	027222
Stroke limiter 230 V AC		084147
Position feedback for E 350 N		083941

## Accessories



Standard console E 250 NT /  
E 350 N (019032)



Console INWARD opening  
E 250 NT / E 350 N (027218)

# E 1500 N



**Spindle drive with slim dimensions  
for heavy leaves in the façade and roof area**

## AREAS OF APPLICATION

- Heavy window elements in the façade and roof area
- Natural ventilation, smoke and heat extraction system
- Inward and outward opening windows with bottom-, top- and side-hung leaves as well as roof windows
- Can be used in the exhaust air and air intake
- Installation on wooden, PVC or metal windows

## PRODUCT FEATURES

- Slim dimensions and an aluminium housing for highest design demands
- Robust and corrosion-resistant design with built-in end position damping
- Syncro drive sets are available for leaf widths over 1200 mm
- Extensive consoles allow versatile installation on main or secondary closing edges
- Syncro set without external control device

## TECHNICAL DATA

### E 1500 N

#### GENERAL INFORMATION

Dimensions (W x H x D) stroke + 302, Ø 36 mm

#### SPECIFICATIONS

Possible stroke lengths 300 mm, 400 mm, 500 mm, 750 mm, 1000 mm

Opening speed smoke and heat extraction 4 mm/s

Opening speed ventilation 4 mm/s

Tensile force (max.) 1500 N

Compressive force (max.) 1500 N

#### ELECTRICAL DATA

Operating voltage 24 V DC

Current consumption 0.8 A

Power consumption (max.) 20 W

Duty rating 30 %

Length of power supply cable 2.5 m

Cable dimensions 3 x 1 mm<sup>2</sup>

Temperature range -5 – 75 °C

IP rating / protection rating IP65 / III

#### FUNCTIONS

Type of stroke shortening default setting

End position cut-off extended electronic

End position cut-off retracted electronic

Overload cut-off ●

#### TYPES OF INSTALLATION

Bottom-hung window	inward opening	frame / leaf
	outward opening	frame

Side-hung window	inward opening	frame / leaf
	outward opening	frame

Top-hung window	inward opening	frame / leaf
	outward opening	frame

Roof window	outward opening	frame
-------------	-----------------	-------

● = YES

## PRODUCT SCALE DRAWING



1 = ø 6 mm with bearing bush, ø 8 mm without bearing bush | 2 = approx. 302 mm + stroke (Solo version)  
approx. 342 mm + stroke (Syncro version)

## TYPES OF INSTALLATION

Main closing edge installation Solo

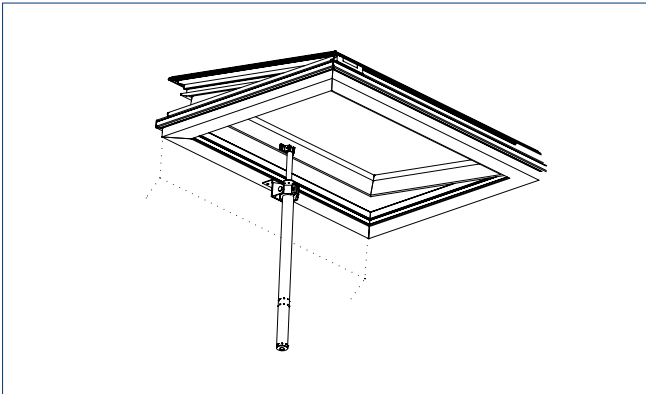

Secondary closing edge installation Syncro

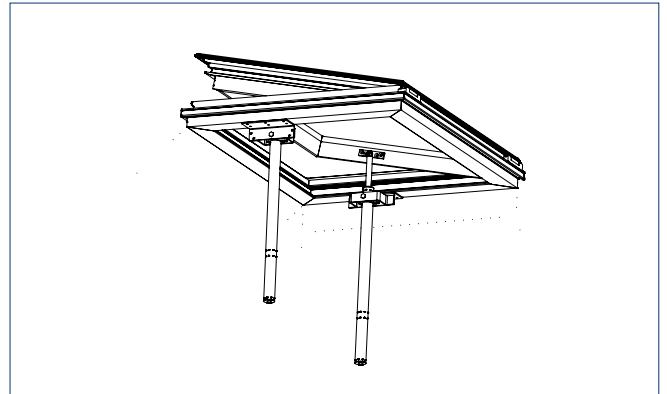

## LEAF DIMENSIONS FOR BOTTOM-HUNG AND TOP-HUNG WINDOWS

Type of window	Minimum leaf height		Maximum leaf width	
	Stroke 300 mm	Stroke 500 mm	Solo	Syncro
Bottom-hung window inward opening	650 mm	1200 mm	max. 1200 mm	max. 2400 mm
Top-hung window outward opening	400 mm	400 mm	max. 1200 mm	max. 2400 mm

## LEAF WEIGHT FOR BOTTOM-HUNG AND TOP-HUNG WINDOWS

Bottom-hung window	Stroke 300 mm		Stroke 500 mm	
	Solo	Syncro	Solo	Syncro
Leaf height 650 – 1200 mm	max. 200 kg	max. 400 kg	max. 170 kg	max. 340 kg
Leaf height 1200 – 1700 mm	max. 250 kg	max. 500 kg	max. 200 kg	max. 400 kg

Top-hung window	Stroke 300 mm		Stroke 500 mm	
	Solo	Syncro	Solo	Syncro
Leaf height 400 – 650 mm	max. 180 kg	max. 360 kg	max. 150 kg	max. 300 kg
Leaf height 650 – 1200 mm	max. 200 kg	max. 400 kg	max. 170 kg	max. 340 kg
Leaf height 1200 – 1700 mm	max. 250 kg	max. 500 kg	max. 200 kg	max. 400 kg

## INSTALLATION WITH ROOF WINDOW CONSOLE H40

The roof window console E 1500 H40 is used to fix the drive to the frame of the roof window.

Please note: Chart and tables only contain guideline values and refer to the applications as shown below. If the installation conditions differ, the values must be determined for each specific project.

### Installation example

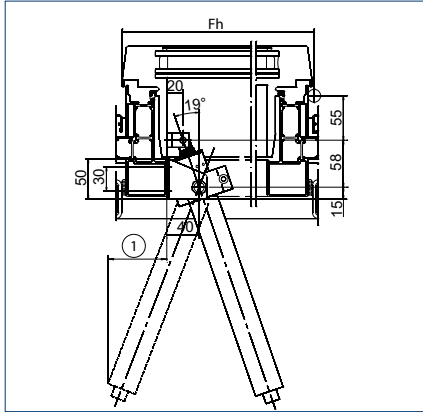

Fh = Leaf height | 1 = Clearance under the window for swivel movement of the drive during the opening movement, see chart

### Opening angle and space needed for swivel

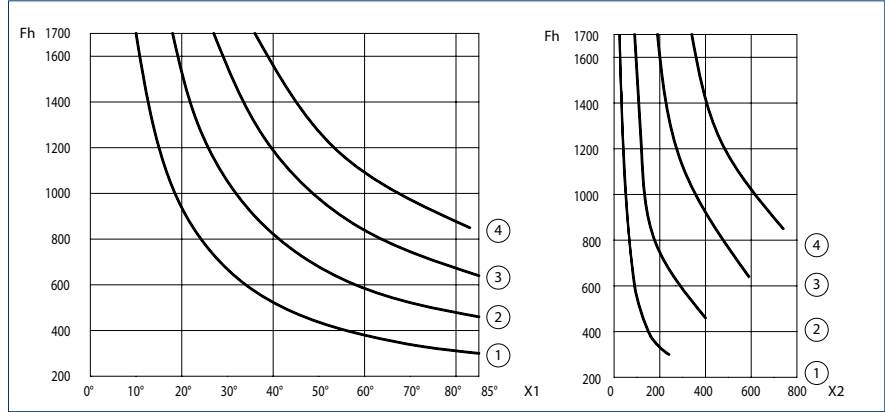

X1 = Opening angle | X2 = Space needed for swivelling (mm) | Fh = Leaf height (mm) | 1 = Stroke 300 | 2 = Stroke 500 | 3 = Stroke 750 | 4 = Stroke 1000

## MINIMUM LEAF HEIGHT FOR E1500 N ON THE ROOF WINDOW (GUIDELINE VALUES\*)

E 1500 N stroke	Leaf height Fh	Opening angle	Space needed for drive swivel under the window
1000 mm	850 mm	approx. 85°	min. 740 mm
750 mm	640 mm	approx. 85°	min. 590 mm
500 mm	460 mm	approx. 85°	min. 400 mm
300 mm	300 mm	approx. 85°	min. 240 mm

\*On account of the wide variety of window profiles and installation options available, it is only possible to list guideline values here. An examination of the installation situation is recommended with limit values.

## EXAMPLE: SPACE NEEDED FOR THE DRIVE SWIVEL UNDER THE ROOF WINDOW AT OPENING WIDTH APPROX. 60°

E 1500 N stroke	Leaf height Fh	Opening angle	Space needed for drive swivel under the window
1000 mm	1100 mm	approx. 60°	min. 540 mm
750 mm	850 mm	approx. 60°	min. 410 mm
500 mm	600 mm	approx. 60°	min. 270 mm
300 mm	380 mm	approx. 60°	min. 160 mm

The space needed under the skylight for the swivel movement of the drive depends on the leaf height (larger leaf height = smaller swivel).

## INSTALLATION WITH ROOF WINDOW CONSOLE H86

The roof window console E 1500 H86 is used to fix the drive to the frame of the roof window.

Please note: Chart and tables only contain guideline values and refer to the applications as shown below. If the installation conditions differ, the values must be determined for each specific project.

### Installation example

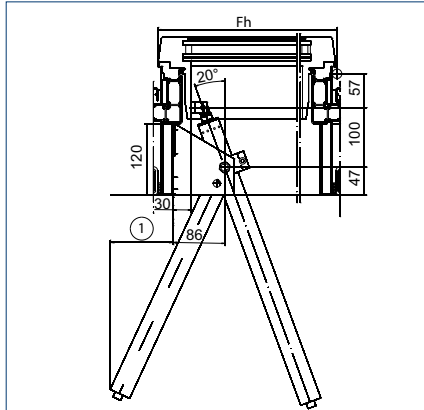

Fh = Leaf height | 1 = Clearance under the window for swivel movement of the drive during the opening movement, see chart

### Opening angle and space needed for swivel

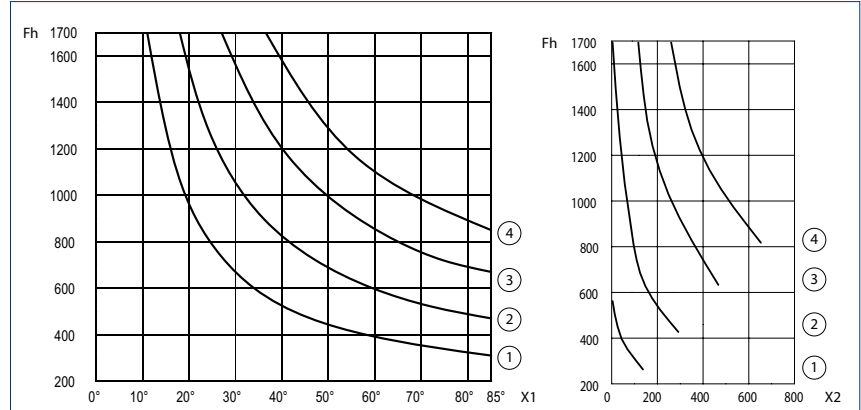

X1 = Opening angle | X2 = Space needed for swivelling (mm) | Fh = Leaf height (mm) | 1 = Stroke 300 | 2 = Stroke 500 | 3 = Stroke 750 | 4 = Stroke 1000

## MINIMUM LEAF HEIGHT FOR E1500 N ON THE ROOF WINDOW (GUIDELINE VALUES\*)

E 1500 N stroke	Leaf height Fh	Opening angle	Space needed for drive swivel under the window
1000 mm	850 mm	approx. 85°	min. 640 mm
750 mm	670 mm	approx. 85°	min. 460 mm
500 mm	470 mm	approx. 85°	min. 290 mm
300 mm	310 mm	approx. 85°	min. 140 mm

\*On account of the wide variety of window profiles and installation options available, it is only possible to list guideline values here. An examination of the installation situation is recommended with limit values.

## EXAMPLE: SPACE NEEDED FOR THE DRIVE SWIVEL UNDER THE ROOF WINDOW AT OPENING WIDTH APPROX. 60°

E 1500 N stroke	Leaf height Fh	Opening angle	Space needed for drive swivel under the window
1000 mm	1100 mm	approx. 60°	min. 460 mm
750 mm	850 mm	approx. 60°	min. 320 mm
500 mm	600 mm	approx. 60°	min. 180 mm
300 mm	400 mm	approx. 60°	min. 70 mm

The space needed under the skylight for the swivel movement of the drive depends on the leaf height (larger leaf height = smaller swivel).

**ORDER INFORMATION**

Designation	Stroke	Version	ID no.
E 1500 N	300 mm	EV1	141894
	300 mm	white RAL 9016	141895
	300 mm	according to RAL	141896
	400 mm	EV1	141897
	400 mm	white RAL 9016	141898
	400 mm	according to RAL	141899
	500 mm	EV1	141900
	500 mm	white RAL 9016	141911
	500 mm	according to RAL	141912
	750 mm	EV1	141913
	750 mm	white RAL 9016	141914
	750 mm	according to RAL	141915
	1000 mm	EV1	141916
	1000 mm	white RAL 9016	141917
1000 mm	according to RAL	141918	
E 1500 N special version Can be configured: stroke, connector, cable length, colour		EV1 according to RAL	141944 141945
E 1500 N SYNCRO	300 mm	EV1	141919
	300 mm	white RAL 9016	141920
	300 mm	according to RAL	141931
	400 mm	EV1	141932
	400 mm	white RAL 9016	141933
	400 mm	according to RAL	141934
	500 mm	EV1	141935
	500 mm	white RAL 9016	141936
	500 mm	according to RAL	141937
	750 mm	EV1	141938
	750 mm	white RAL 9016	141939
	750 mm	according to RAL	141940
	1000 mm	EV1	141941
	1000 mm	white RAL 9016	141942
1000 mm	according to RAL	141943	
E 1500 N SYNCRO special version Consists of 2 drives with integrated Syncro control		EV1 according to RAL	141946 141947
<b>ACCESSORIES</b>			
Console E 1500 NSK W-HU suitable for installation on the secondary closing edge of roof windows (Schüco AWS57 RO, Wicona WT 50/60, Hueck VF 50/60).			136184
Console E 1500 NSK suitable for installation on the secondary closing edge of roof windows			130524
Console bracket E 1500 suitable for installation on the main closing edge of roof windows			136201
Conical sleeve E 1500		silver-coloured	121215
		white RAL 9016	121216
		according to RAL	121217
Leaf bracket E 1500 FS		silver-coloured	123085
		white RAL 9016	123086
		according to RAL	123087



## ORDER INFORMATION

Designation	Stroke	Version	ID no.
Leaf bracket E 1500 HSK HE suitable for installation on the main closing edge of roof windows (Heral), can also be used for E 250 NT			136190
Leaf bracket E 1500 NSK A-HU suitable for installation on the secondary closing edge of roof windows (Alcoa AA 100, Hueck VF 50/60), can also be used for E 250 NT			136189
Leaf bracket E 1500 NSK HE suitable for installation on the secondary closing edge of roof windows (Heral 85 D), also suitable for E 250 NT			136188
Leaf bracket E 1500 NSK W-HU suitable for installation on the secondary closing edge of roof windows (Wicona WT 50/60, Hueck 85 E), can also be used for E 250 NT			136187
Leaf bracket E 1500/ E 3000 NSK AP suitable for installation on the secondary closing edge of roof windows (Aluprof MB-SR50), can also be used for E 250 NT			140713
Leaf bracket E 1500/ E 3000 NSK S suitable for installation on the secondary closing edge of roof windows (Schüco AWS57 RO)			136186
Roof window console H40 E 1500		silver-coloured white RAL 9016 according to RAL121223	121221 121222
Roof window console H86 E 1500		silver-coloured white RAL 9016 according to RAL121226	121224 121225

# Accessories



Leaf bracket E 1500



Leaf bracket E 1500 FS (123085)



Conical sleeve E 1500 (121215)



Console E 1500



Roof window console H40 E  
1500 (121221)



Roof window console H86 E  
1500 (121224)

# E 1500 S



Spindle drive  
with high opening and closing speed

## AREAS OF APPLICATION

- Heavy windows in the roof area
- Natural ventilation, smoke and heat extraction system, SHEV according to EN 12101-2
- Use in the exhaust air system
- Installation on wooden, PVC or metal windows

## PRODUCT FEATURES

- High pressure force and high speed
- Max. opening width of 1000 mm achieved in less than 60 seconds
- Robust and corrosion-resistant design with built-in end position damping
- Syncro drive sets are available for leaf widths over 1200 mm
- Aluminium housing for highest design demands
- Extensive consoles allow versatile installation on main or secondary closing edges
- Syncro set without external control device
- SHEV tested according to EN 12101-2

**TECHNICAL DATA****E 1500 S****GENERAL INFORMATION**

Dimensions (W x H x D)	Stroke + 465, Ø 50 mm
------------------------	-----------------------

**SPECIFICATIONS**

Possible stroke lengths	500 mm, 750 mm, 1000 mm
Opening speed smoke and heat extraction	16 mm/s
Opening speed ventilation	16 mm/s
Tensile force (max.)	1500 N
Compressive force (max.)	1500 N
Holding force (max.)	25000 N *

**ELECTRICAL DATA**

Operating voltage	24 V DC
Current consumption	4 A
Power consumption (max.)	75 W
Duty rating	30 %
Length of power supply cable	3 m
Cable dimensions	3 x 1 mm <sup>2</sup>
Temperature range	-5 – 75 °C
IP rating / protection rating	IP54 / III

**FUNCTIONS**

Type of stroke shortening	Default setting
End position cut-off extended	electronic
End position cut-off retracted	electronic
Complete opening within 60 s	yes, up to 1000 mm stroke
SHEV tested according to EN 12101-2	yes, up to 1000 mm stroke

**TYPES OF INSTALLATION**

Roof window	outward opening	Frame
-------------	-----------------	-------

\* = depends on installation

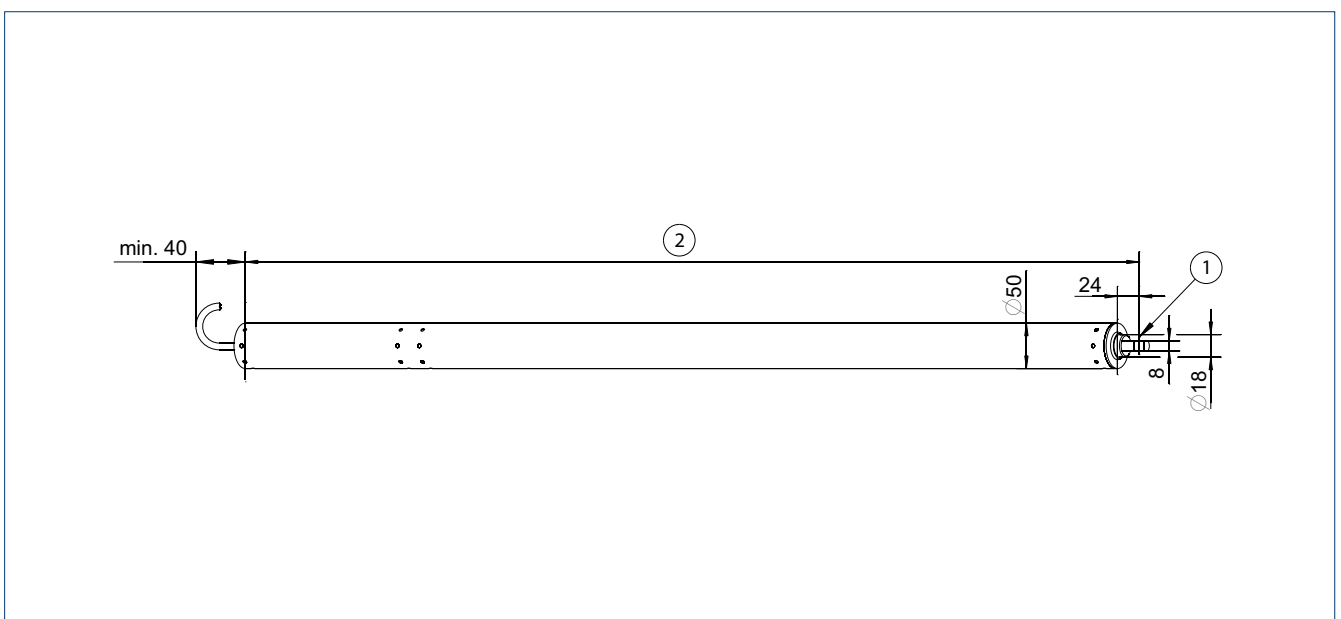
**PRODUCT SCALE DRAWING**

1 = ø 6 mm with bearing bush, ø 8 mm without bearing bush | 2 = approx. 465 mm + stroke

## TYPES OF INSTALLATION

Main closing edge installation Solo

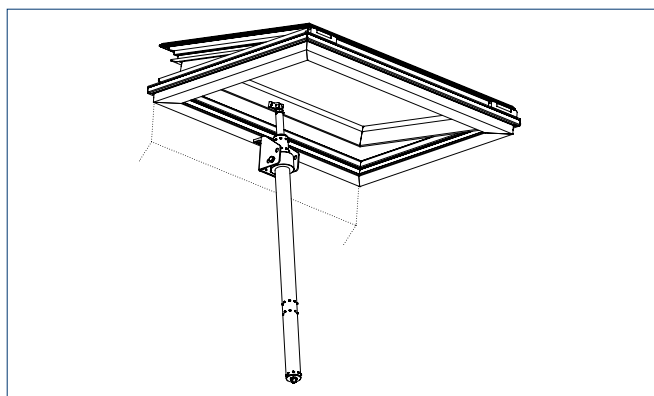

Secondary closing edge installation Syncro

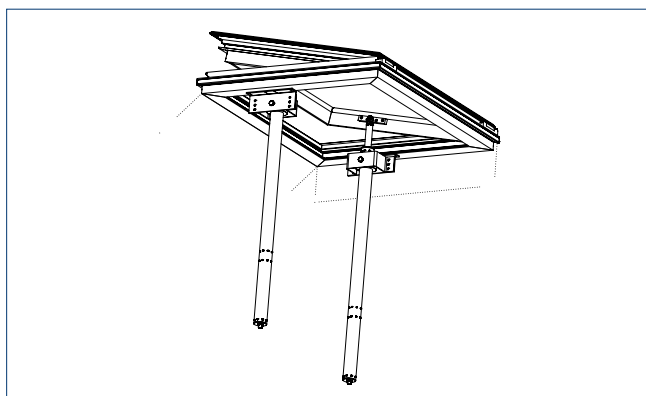

Roof windows	Solo	Syncro
Leaf weights for all strokes	max. 180 kg	max. 360 kg
Maximum leaf width	max. 1200 mm	max. 2400 mm

## ORDER INFORMATION

Designation	Stroke	Version	ID no.
E 1500 S	500 mm	EV1	162381
	750 mm	EV1	162382
	1000 mm	EV1	162383
E 1500 S Can be configured: stroke, cable length, colour		according to RAL	162384
E 1500 S SYNCRO Consists of 2 drives with integrated Syncro control	500 mm	EV1	162385
	750 mm	EV1	162386
	1000 mm	EV1	162387
E 1500 S SYNCRO Can be configured: stroke, cable length, colour, Syncro 2-4		according to RAL	162388

Designation	Stroke	Version	ID no.
<b>ACCESSORIES</b>			
Roof window console E 3000		silver-coloured white RAL 9016 according to RAL	121280 121291 121292
Console E 3000 NSK S suitable for installation on the secondary closing edge of roof windows (Schüco AWS57 RO) Supplied by GEZE without conical sleeve ID no. 121274			136183
Console E 3000 NSK suitable for installation on the secondary closing edge of roof windows. Supplied by GEZE without conical sleeve ID no. 121274			130525
Console bracket E 3000 HSK suitable for installation on the main closing edge of roof windows			136202
Console bracket E 3000 NSK suitable for installation on the secondary closing edge of roof windows			136203
Console bracket E 3000 NSK AP suitable for installation on the secondary closing edge of roof windows			140714
Conical sleeve E 3000		silver-coloured white RAL 9016 according to RAL	121274 121275 121276
Leaf bracket E 3000		silver-coloured white RAL 9016 according to RAL	121277 121278 121279
Leaf bracket E 3000 HSK HE suitable for installation on the main closing edge of roof windows (Heroal 085 D)			136207
Leaf bracket E 3000 NSK A-HU suitable for installation on the secondary closing edge of roof windows (Alcoa AA 100, Hueck VF 50/60)			136205
Leaf bracket E 3000 NSK W-HU suitable for installation on the secondary closing edge of roof windows (Wicona WT 50/60, Hueck 85 E)			136204
Leaf bracket E 1500/ E 3000 NSK AP suitable for installation on the secondary closing edge of roof windows			140715
Leaf bracket E 3000 NSK HE suitable for installation on the secondary closing edge of roof windows (Heroal 85 D)			136206

## Accessories



Conical sleeve E 3000 (121274)



Leaf bracket E 3000 (121277)



Roof window console E 3000  
(121280)

# E 3000



## Spindle drive for particularly heavy roof window elements

### AREAS OF APPLICATION

- Very heavy windows in the roof area
- Natural ventilation, smoke and heat extraction system, SHEV according to EN 12101-2
- Use in the exhaust air system
- Installation on wooden, PVC or metal windows
- Frame installation

### PRODUCT FEATURES

- Very high tensile force and force of pressure
- Robust and corrosion-resistant design with built-in end position damping
- Aluminium housing for highest design demands
- Extensive consoles allow versatile installation on main or secondary closing edges
- Synchronisation of max. four drives without external control unit
- SHEV tested according to EN 12101-2

**TECHNICAL DATA****E 3000****GENERAL INFORMATION**

Dimensions (W x H x D)	stroke + 465, Ø 50 mm
------------------------	-----------------------

**SPECIFICATIONS**

Possible stroke lengths	500 mm, 750 mm, 1000 mm
Opening speed smoke and heat extraction	7.8 mm/s
Opening speed ventilation	7.8 mm/s
Tensile force (max.)	3000 N
Compressive force (max.)	3000 N
Holding force (max.)	25000 N*

**ELECTRICAL DATA**

Operating voltage	24 V DC
Current consumption	5 A
Power consumption (max.)	75 W
Duty rating	20 %
Length of power supply cable	3 m
Cable dimensions	3 x 1 mm <sup>2</sup>
Temperature range	-5 – 75 °C
IP rating / protection rating	IP54

**FUNCTIONS**

Type of stroke shortening	default setting
End position cut-off extended	electronic
End position cut-off retracted	electronic
Complete opening within 60 s	yes, up to 300 mm stroke
SHEV tested according to EN 12101-2	yes, up to 300 mm stroke

**TYPES OF INSTALLATION**

Roof window	outward opening	frame
-------------	-----------------	-------

\* = depends on installation

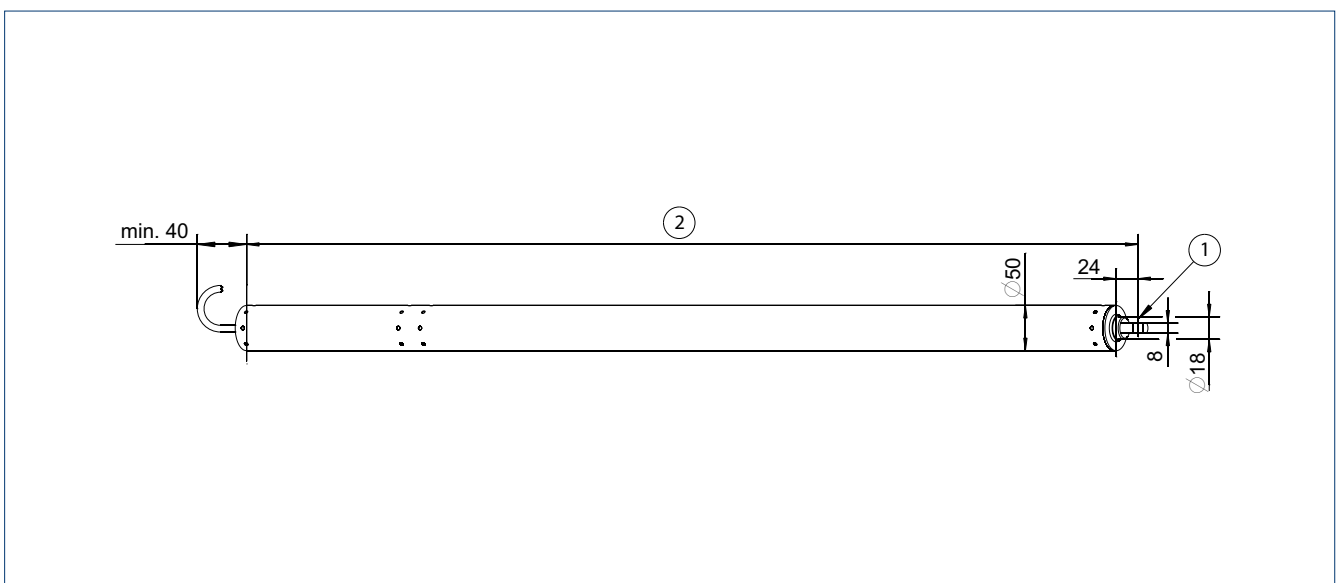
**PRODUCT SCALE DRAWING**

1 = ø 6 mm with bearing bush, ø 8 mm without bearing bush | 2 = approx. 465 mm + stroke

## TYPES OF INSTALLATION

Main closing edge installation Solo

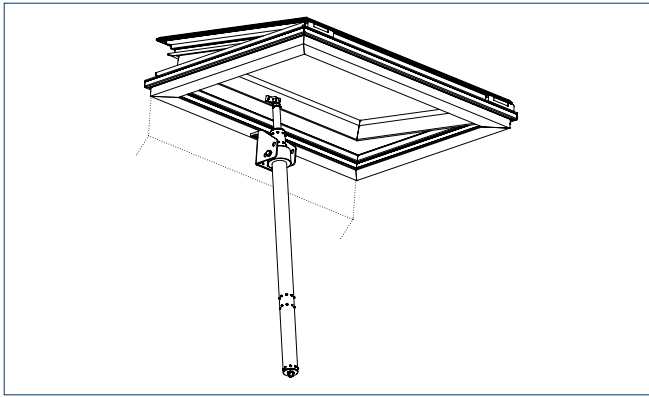

Secondary closing edge installation Syncro

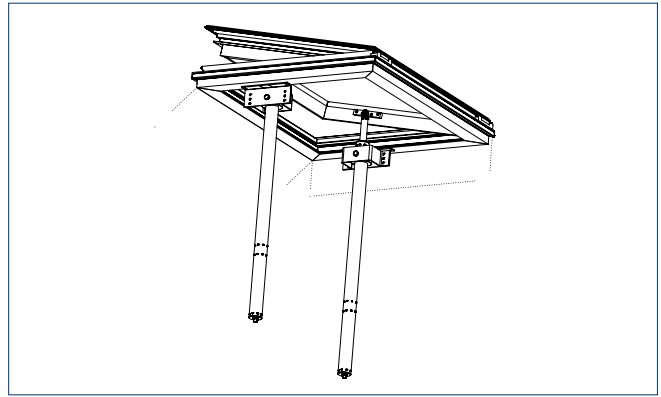

### Calculation of the swivelling range

The space needed under the window for the swivel movement of the drive depends on the height of the leaf. The larger the leaf height, the smaller the swivel.

Application	Solo	Syncro
Leaf weights for all strokes	max. 300 kg	max. 600 kg
Maximum leaf width	max. 1200 mm	max. 2400 mm

→ **Note:** The Syncro version is recommended from 1.2 m main closing edge, depending on the profile system used.

## INSTALLATION WITH ROOF WINDOW CONSOLE H86

The roof window console E 3000 H86 is used to fix the drive to the frame of the roof window. This console can also be used for the E 1500 S.

**Please note:** Chart and tables only contain guideline values and refer to the applications as shown below. If the installation conditions differ, the values must be determined for each specific project.

## INSTALLATION EXAMPLES

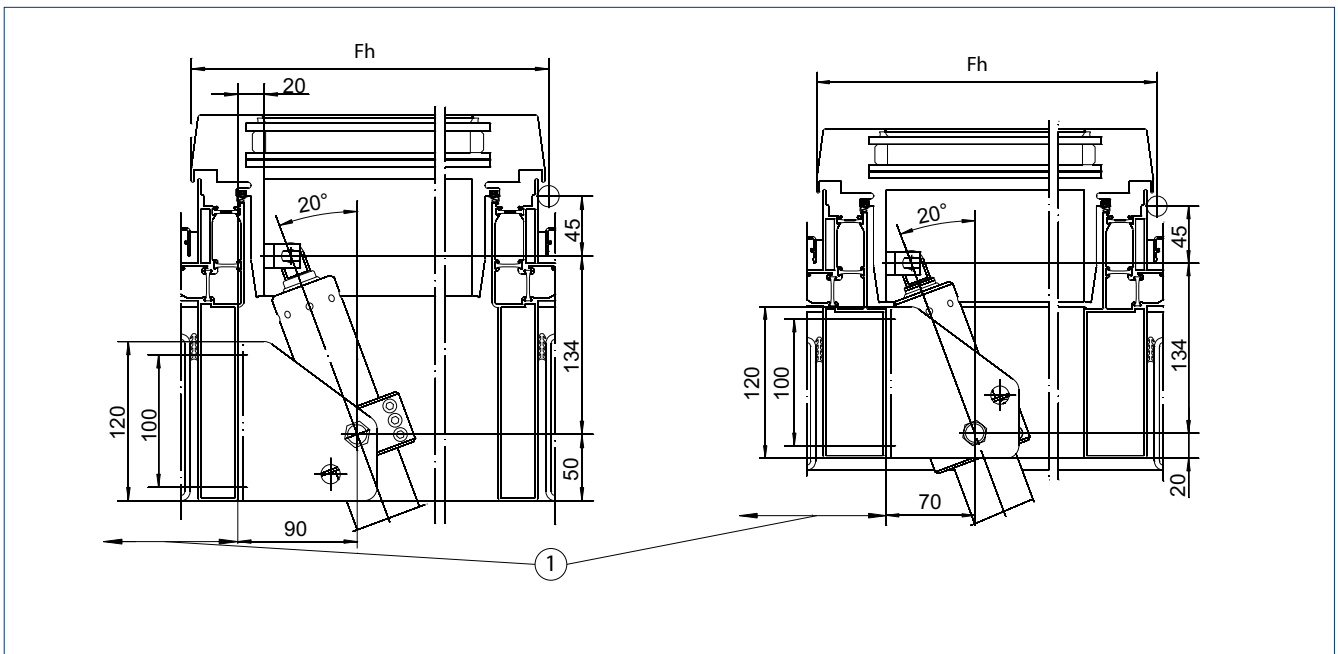

Fh = Leaf height | 1 = Clearance under the window for swivel movement of the drive during the opening movement, see chart



**INSTALLATION EXAMPLE**

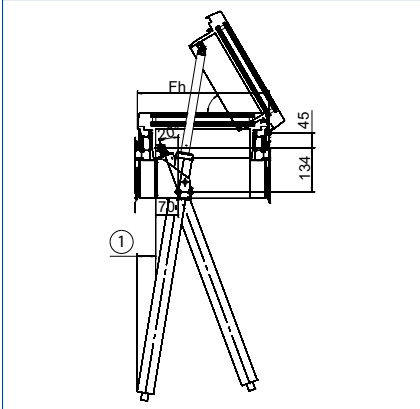

Fh = Leaf height | 1 = Clearance under the window for swivel movement of the drive during the opening movement, see chart

**OPENING ANGLE AND SPACE NEEDED FOR SWIVEL**

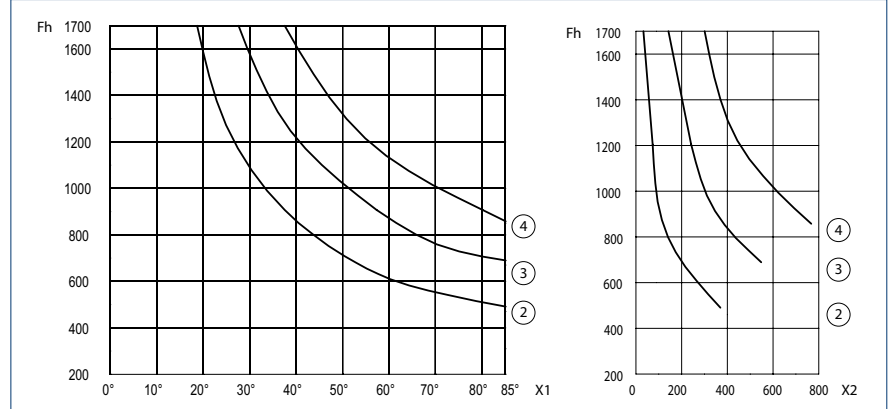

X1 = Opening angle | X2 = Space needed for swivel (mm) | Fh = Leaf height (mm) | 2 = Stroke 500 | 3 = Stroke 750 | 4 = Stroke 1000

**MINIMUM LEAF HEIGHT FOR ROOF WINDOW (GUIDELINE VALUES)**

E 1500 S / E 3000 stroke	Leaf height Fh	Opening angle	Space needed for drive swivel under the window
1000 mm	850 mm	approx. 85°	min. 770 mm
750 mm	680 mm	approx. 85°	min. 550 mm
500 mm	480 mm	approx. 85°	min. 370 mm

**EXAMPLE: SPACE NEEDED FOR THE DRIVE SWIVEL UNDER THE ROOF WINDOW AT OPENING WIDTH APPROX. 60°**

E 1500 S / E 3000 stroke	Leaf height Fh	Opening angle	Space needed for drive swivel under the window
1000 mm	1100 mm	approx. 60°	min. 520 mm
750 mm	850 mm	approx. 60°	min. 380 mm
500 mm	600 mm	approx. 60°	min. 240 mm

The space needed under the window for the swivel movement of the drive depends on the leaf height (larger leaf height = smaller swivel)

## ORDER INFORMATION

Designation	Stroke	Version	ID no.
GEZE E 3000	500 mm	EV1	162389
	750 mm	EV1	162390
	1000 mm	EV1	162391
E 3000 SYNCRO consisting of two drives with integrated synchro control	500 mm	EV1	162393
	750 mm	EV1	162394
	1000 mm	EV1	162395
E 3000 special version Can be configured: stroke, cable length, colour		according to RAL	162392
E 3000 SYNCRO special version Can be configured: stroke, cable length, colour, Syncro 2-4		according to RAL	162396

## ACCESSORIES

Roof window console E 3000	silver-coloured white RAL 9016 according to RAL	121280 121291 121292
Console E 3000 NSK S suitable for installation on the secondary closing edge of roof windows (Schüco AWS57 RO). Supplied by GEZE without conical sleeve ID no. 121274		136183
Console E 3000 NSK S suitable for installation on the secondary closing edge of roof windows Supplied by GEZE without conical sleeve ID no. 121274		130525
Console bracket E 3000 NSK suitable for installation on the main closing edge of roof windows		136202
Console bracket E 3000 NSK suitable for installation on the secondary closing edge of roof windows		136203
Console bracket E 3000 NSK AP suitable for installation on the secondary closing edge of roof windows		140714
Conical sleeve E 3000	silver-coloured white RAL 9016 according to RAL	121274 121275 121276
Leaf bracket E 3000	silver-coloured white RAL 9016 according to RAL	121277 121278 121279
Leaf bracket E 3000 HSK HE suitable for installation on the main closing edge of roof windows (Heral 085 D)		136207
Leaf bracket E 3000 NSK A-HU suitable for installation on the secondary closing edge of roof windows (Alcoa AA 100, Hueck VF 50/60)		136205
Leaf bracket E 3000 NSK W-HU suitable for installation on the secondary closing edge of roof windows (Wicona WT 50/60, Hueck 85 E)		136204
Leaf bracket E 1500/E 3000 NSK AP suitable for installation on the secondary closing edge of roof windows		140715
Leaf bracket E 3000 NSK HE suitable for installation on the secondary closing edge of roof windows (Heral 85 D)		136206

# Accessories



Conical sleeve E 3000 (121274)



Leaf bracket E 3000 (121277)



Roof window console E 3000 (121280)

# E 212



## Electric linear drive for automation of slimline skylight openers

### AREAS OF APPLICATION

- Automation of GEZE OL 90, OL 95 N and OL 320 fanlight openers
- Natural ventilation (24 V or 230 V version) in the façade area
- Inward opening bottom-hung leaves
- Automation of louvre windows
- Installation on wooden, PVC or metal windows
- Frame installation

### PRODUCT FEATURES

- Cost-effective and simple motorised solution for activating several scissor stays
- Slim and discreet appearance integrates perfectly into the façade design
- Opening width variably adjustable over stroke length and can be adjusted as required
- Load cut-off and integrated limit switch as well as stroke are adjustable
- Completely pre-mounted assembly groups facilitate installation

## TECHNICAL DATA

E 212

### GENERAL INFORMATION

Dimensions (H x W x L) 30 x 80 x 210 mm

### SPECIFICATIONS

Adjustable stroke 42 – 70 mm

Tensile force and force of pressure 1500 N

Running time (under load) approx. 35 s for 52 mm stroke

Temperature range -20 – 60 °C

### ELECTRICAL DATA

Power consumption 90 W

Current consumption with 230 V AC: 0.2 A  
with 24 V DC: 1.2 A

IP rating IP42

Operating voltage 230 V AC / 24 V DC

Cable/length Connector version

### TYPES OF INSTALLATION

Bottom-hung window inward opening Frame

Louvre window Frame

## PRODUCT SCALE DRAWING

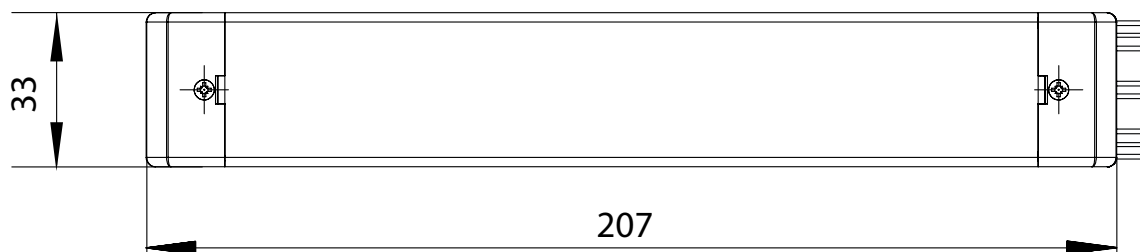

## TYPES OF INSTALLATION

### PERMISSIBLE LEAF WIDTH AND PANEL WEIGHT DEPENDING ON THE I DIMENSION

(for installation with OL 90 N)

Horizontal installation

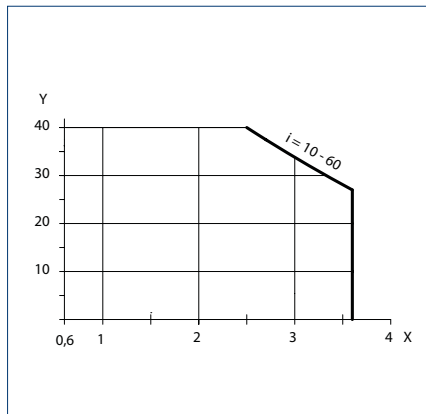

X = Total leaf width (sum of all leaf widths) [m] | Y = panel weight [kg/m²]

Vertical installation

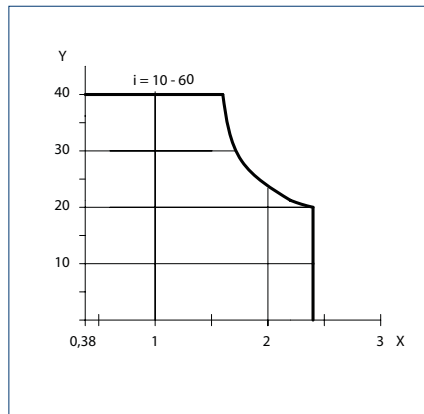

X = Total leaf width (sum of all leaf widths) [m] | Y = panel weight [kg/m²]

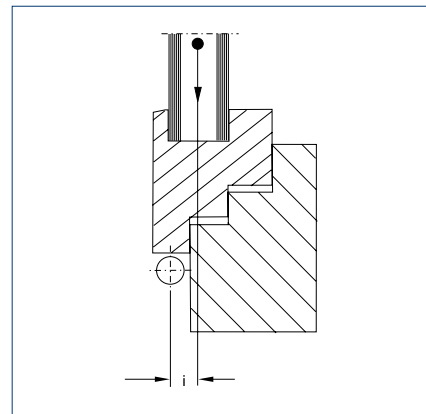

i = Clearance measurement between the leaf's centre of gravity and the hinge pivot point [mm]

### GEZE E 212: PERMISSIBLE LEAF WIDTH AND PANEL WEIGHT DEPENDING ON THE I DIMENSION

(for installation with OL 320)

Horizontal installation

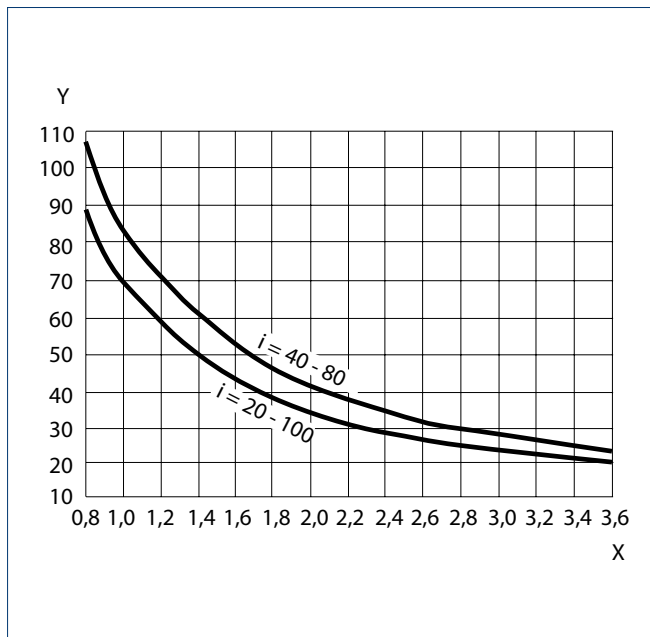

X = Total leaf width (sum of all leaf widths) [m] | Y = panel weight [kg/m²]

Vertical installation

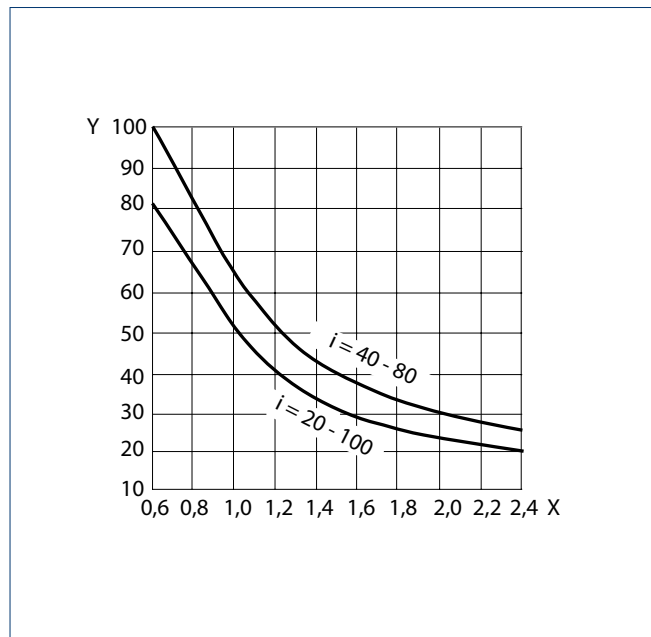

X = Total leaf width (sum of all leaf widths) [m] | Y = panel weight [kg/m²]

## POSSIBLE LEAF WIDTHS GEZE E 212

Number of scissor stays required	Leaf width a with horizontal installation	Leaf width a with vertical installation
1 scissor stay	800 – 1200 mm	600 – 1200 mm
2 scissor stays	1201 – 2400 mm	1201 – 2400 mm
3 scissor stays	2401 – 3600 mm	–
	Leaf height b min. 400 mm <sup>1)</sup>	Leaf height b min. 500 mm <sup>2)</sup>

– = no

1 = If the opening width is limited to 190 mm over the motor stroke, b is min. 290 mm l

2 = If there is no jamb at the bottom, b is min. 400 mm

## ORDER INFORMATION

Designation	Version	Version	ID no.
E 212 R1 electric linear drive, 230 V With 1 relay, for group control via 1 selector switch	66 mm	silver-coloured	020835
	66 mm	dark bronze	020836
	66 mm	white RAL 9016	020839
	66 mm	according to RAL	020838
E 212 R electric linear drive, 230 V With 2 relays, for group control via any number of vent switches	66 mm	silver-coloured	005428
	66 mm	dark bronze	005429
	66 mm	white RAL 9016	015435
	66 mm	according to RAL	006683
E 212 electric linear drive, 24 V Current consumption 1.2 A	66 mm	silver-coloured	010899
	66 mm	dark bronze	010901
	66 mm	white RAL 9016	015540
	66 mm	according to RAL	010915

## ACCESSORIES

Safety scissor stay no. 35	galvanised	014499
Safety scissor stay no. 60	galvanised	133814
Synchronising unit for GEZE electric drives with 24 V		111198
Synchronising unit for GEZE electric drives with 230 V		054371
Synchronising unit for GEZE E 212 R1 230 V electric drive		026762

→ **Note:** For installation on a bottom-hung leaf, the installation of separate safety scissor stays is mandatory for product liability reasons. They represent an additional safety device which guarantees the permanent connection of leaf and frame.

# E 170



## Scissor drive as design solution for optimum ventilation

### AREAS OF APPLICATION

- Natural ventilation (24 V or 230 V version) in the façade area
- Inward opening bottom-hung leaves
- Installation on wooden, PVC or metal windows
- Frame installation

### PRODUCT FEATURES

- Combines the OL 90 N fanlight opener and the E 212 electric linear drive in a single product
- Scissor stays integrated in the cover profile
- Attractive design and additional protection against contamination
- Opening width is variably adjustable and can therefore be flexibly regulated on site

**TECHNICAL DATA**

**E 170**

**GENERAL INFORMATION**

Dimensions (W x H x D)	547 x 35 x 85 mm
Height	85 mm
Depth	35 mm
Space needed on frame (min.)	40 mm

**SPECIFICATIONS**

i dimension	10 – 60 mm
Overlap height	0 – 25 mm
Leaf width	550 – 1200 mm
Opening width	170 mm
Leaf weight (max.)	100 kg

**ELECTRICAL DATA**

Operating voltage	with 230 V AC: 230 V (+60 %/-10 %), with 24 V DC: 24 V (20 – 30 V)
Current consumption	with 230 V AC: 0.2 A with 24 V DC: 1.2 A
Power consumption	with 230 V AC: 90 W with 24 V DC: 29 W
Power consumption (max.)	90 W
Residual ripple	with 24 V DC: 20 %
Frequency	with 230 V AC: 50 / 60 Hz
Duty rating	25 %
Temperature range	-5 – 70 °C
IP rating / protection rating	IP42

**FUNCTIONS**

Stroke length settable	●
End position cut-off extended	Limit switch
End position cut-off retracted	Limit switch

**TYPES OF INSTALLATION**

Bottom-hung window	inward opening	Frame
--------------------	----------------	-------

● = YES

**PRODUCT SCALE DRAWING**

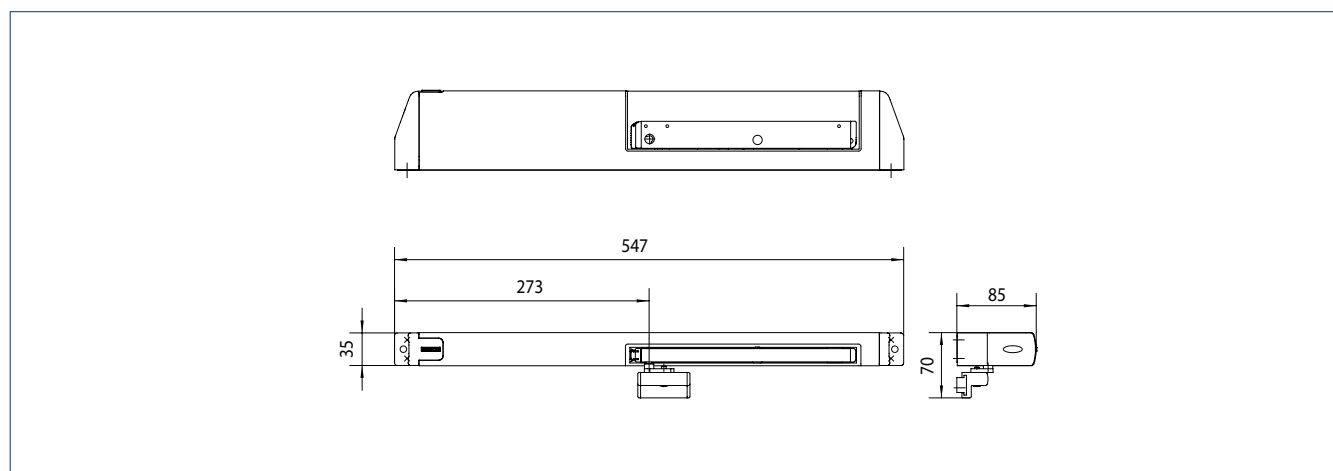



**MAXIMUM WEIGHT PER UNIT AREA DEPENDING ON LEAF DIMENSIONS**

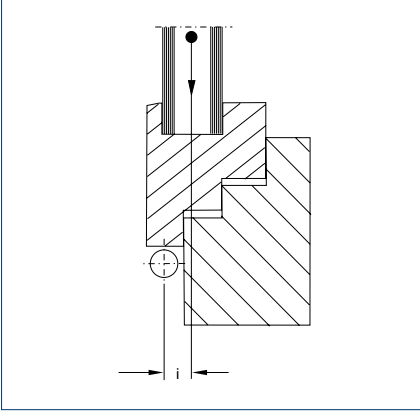

i = Clearance measurement between the leaf's centre of gravity and the hinge pivot point [mm]

**I DIMENSION = 20 - 70**

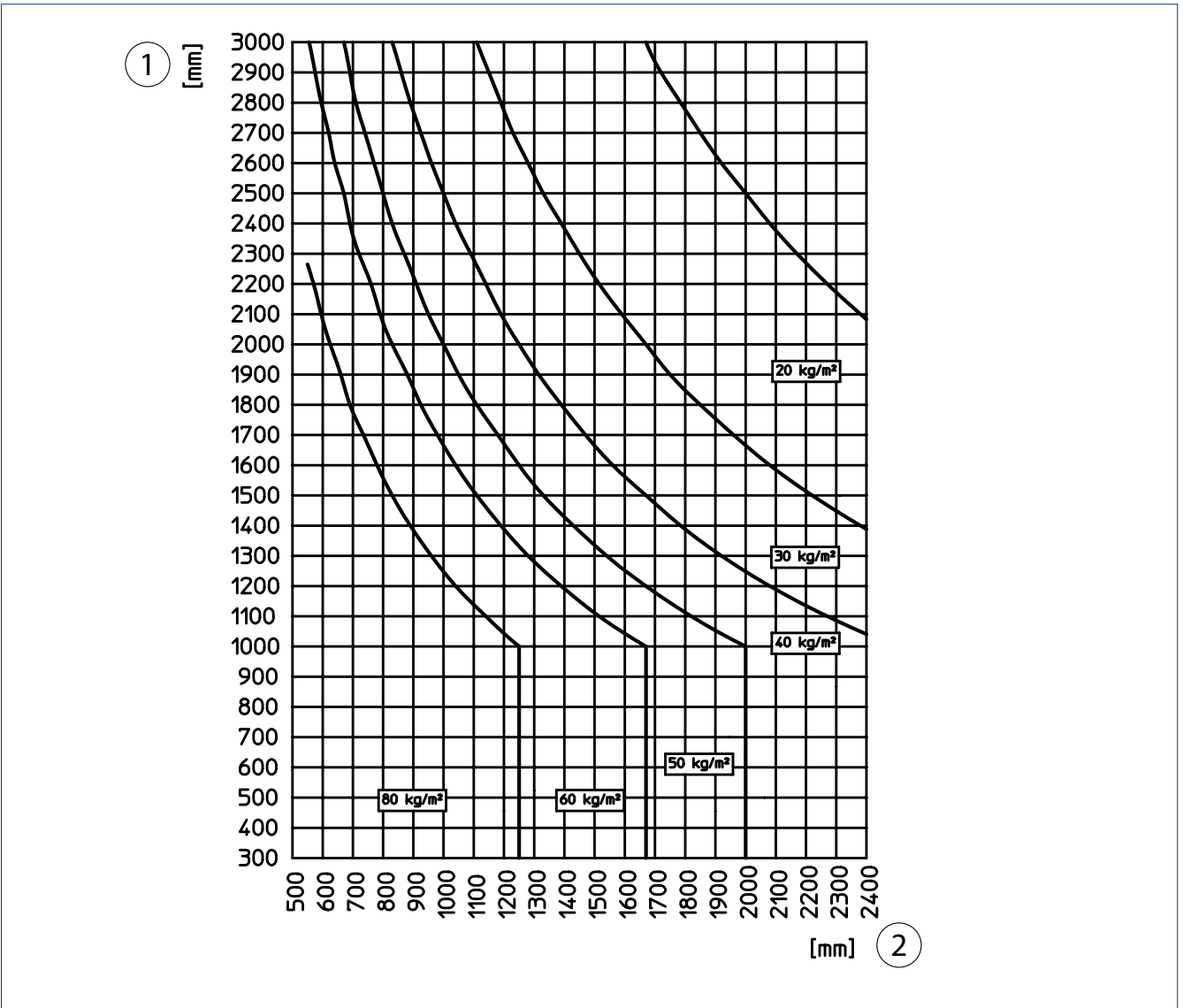

1 = Leaf height | 2 = Leaf width

I DIMENSION = 30 - 60

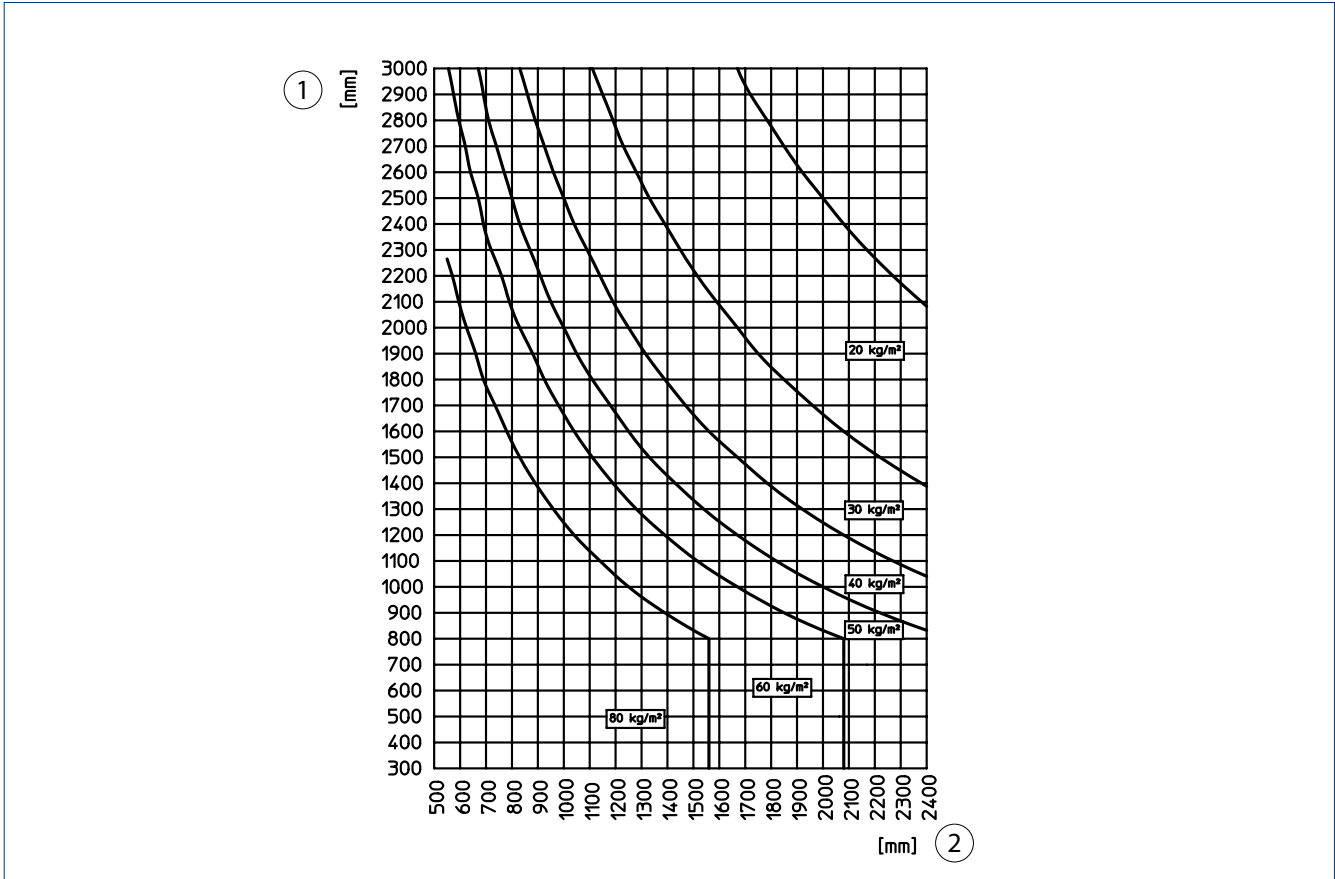

1 = Leaf height | 2 = Leaf width

I DIMENSION = 40 - 50

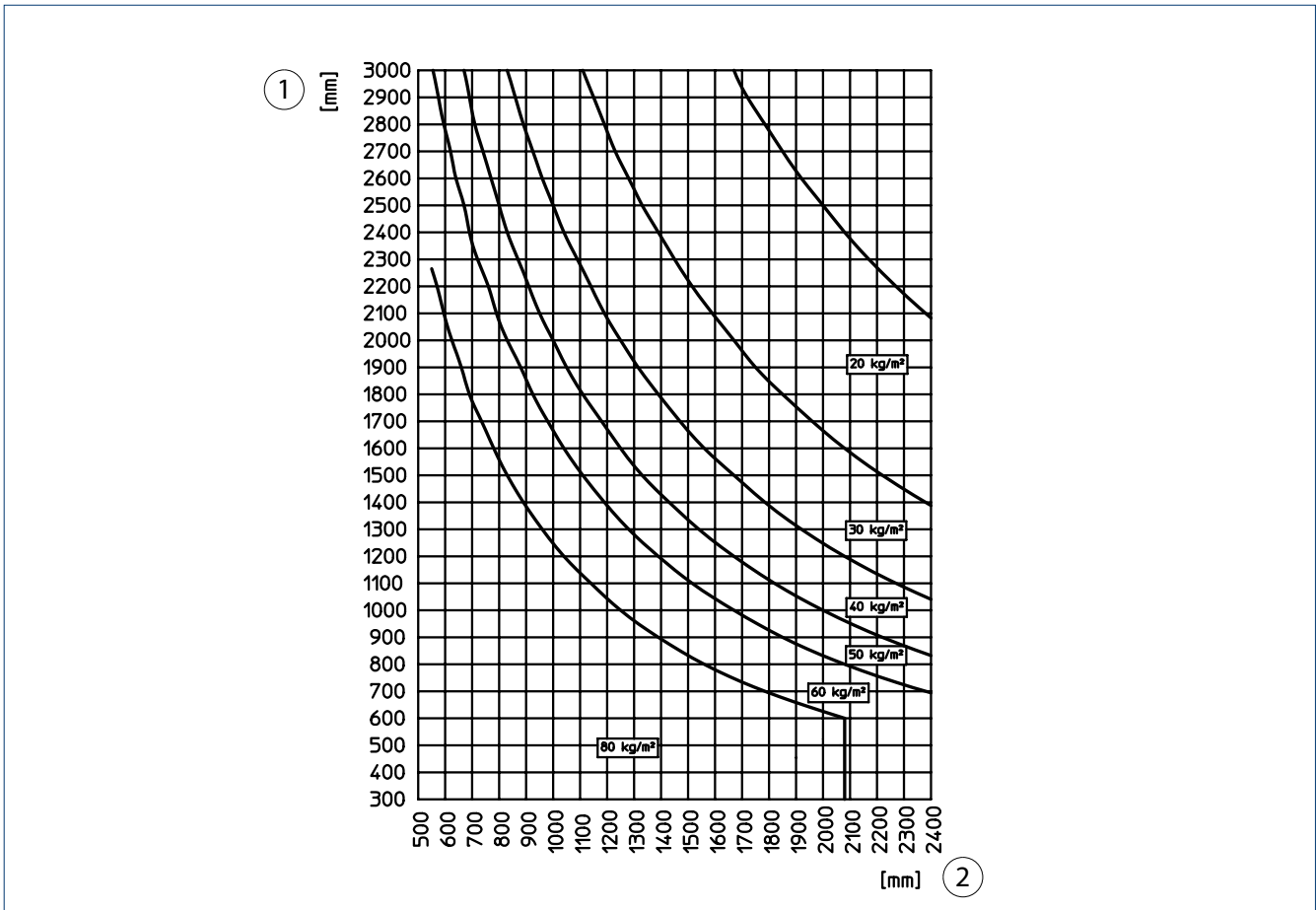

1 = Leaf height | 2 = Leaf width

## TYPES OF INSTALLATION

### E 170 SCISSOR DRIVE

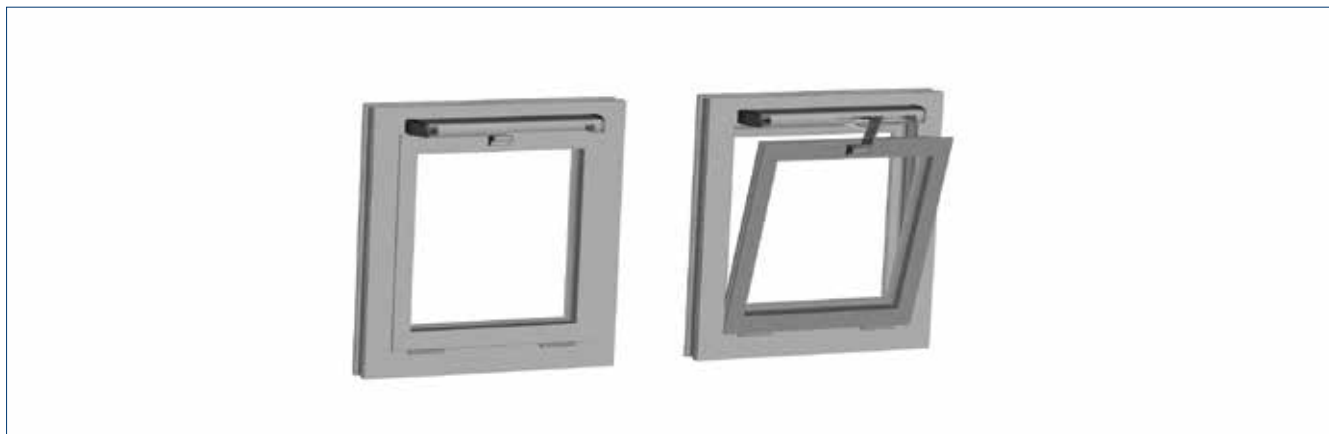

Leaf width 550 – 1200 mm

### FITTING DIMENSIONS E 170

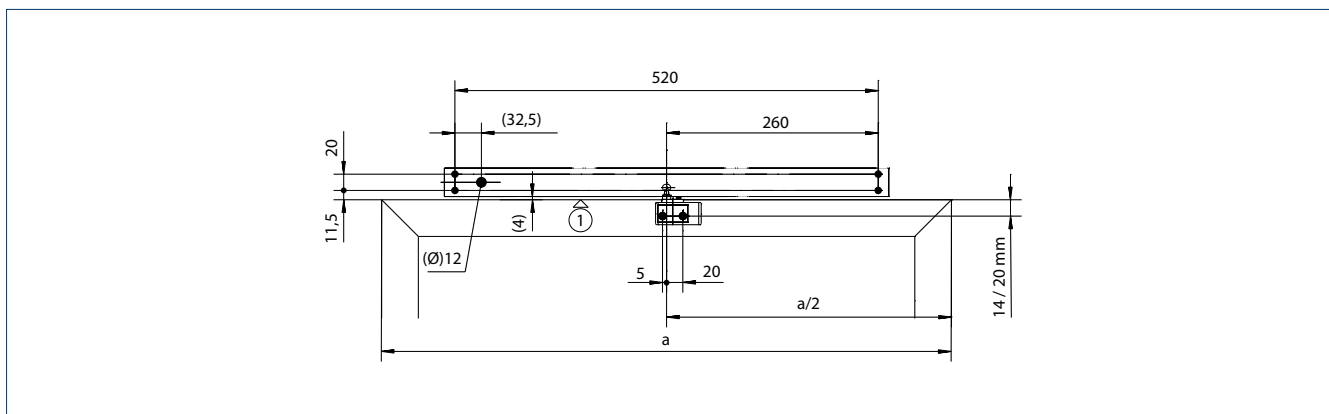

1 = Top edge leaf

## ORDER INFORMATION

Designation	Version	ID no.
E 170, 230 V incl. leaf bracket	EV1 white RAL 9016 according to RAL	128707 128708 128709
E 170, 24 V incl. leaf bracket	EV1 white RAL 9016 according to RAL	128711 128712 128713
<b>ACCESSORIES</b>		
Standard leaf bracket suitable for E 170	EV1 white RAL 9016 according to RAL	128925 128926 128927
Sliding leaf bracket suitable for E 170	EV1 white RAL 9016 according to RAL	128928 128929 128930
Variable cover for E 170 The design set for GEZE scissor drives	EV1 white RAL 9016 according to RAL	128922 128923 128924
Locking module for E 170 A = 11.5 mm	EV1 white RAL 9016 according to RAL	128935 128936 128937
Locking module for E 170 A = 15.5 mm	EV1 white RAL 9016 according to RAL	128938 128939 128940
Locking module for E 170 A = 8.5 mm	EV1 white RAL 9016 according to RAL	128932 128933 128934

# E 170/2



## Scissor drive as design solution for optimal ventilation of wide windows

### AREAS OF APPLICATION

- Natural ventilation (24 V or 230 V version) in the façade area
- Solution for activation of wide windows
- Inward opening bottom-hung leaves
- Installation on wooden, PVC or metal windows
- Frame installation

### PRODUCT FEATURES

- Combines the OL 90 N fanlight opener and the E 212 electric linear drive in a single product
- Scissor stays integrated in the cover profile
- Attractive design and additional protection against contamination
- Opening width is variably adjustable and can therefore be flexibly regulated on site

**TECHNICAL DATA****E 170/2****GENERAL INFORMATION**

Dimensions (W x H x D)	length 900 mm: 900 x 35 x 85 mm length 1600 mm: 1600 x 35 x 85 mm
Height	85 mm
Depth	35 mm
Space needed on frame (min.)	40 mm

**SPECIFICATIONS**

i dimension	10 – 60 mm
Overlap height	0 – 25 mm
Leaf width	length 900 mm: 900 – 1600 mm length 1600 mm: 1600 – 2400 mm
Opening width	170 mm
Leaf weight (max.)	100 kg

**ELECTRICAL DATA**

Operating voltage	with 230 V AC: 230 V (+60 %/-10 %), with 24 V DC: 24 V (20 – 30 V)
Current consumption	with 230 V AC: 0.2 A with 24 V DC: 1.2 A
Power consumption	with 230 V AC: 90 W with 24 V DC: 29 W
Power consumption (max.)	90 W
Residual ripple	with 24 V DC: 20 %
Frequency	with 230 V AC: 50 / 60 Hz
Duty rating	25 %
Temperature range	-5 – 60 °C
IP rating / protection rating	IP42

**FUNCTIONS**

Stroke length settable	●
End position cut-off extended	limit switch
End position cut-off retracted	limit switch

**TYPES OF INSTALLATION**

Bottom-hung window	inward opening	frame
--------------------	----------------	-------

● = YES

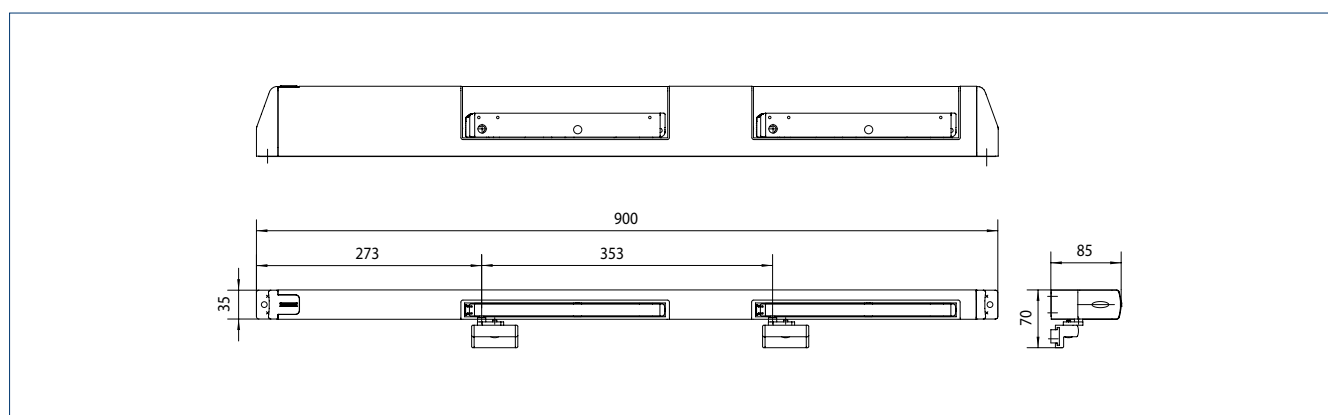
**PRODUCT SCALE DRAWING**

**MAXIMUM WEIGHT PER UNIT AREA DEPENDING ON LEAF DIMENSIONS**

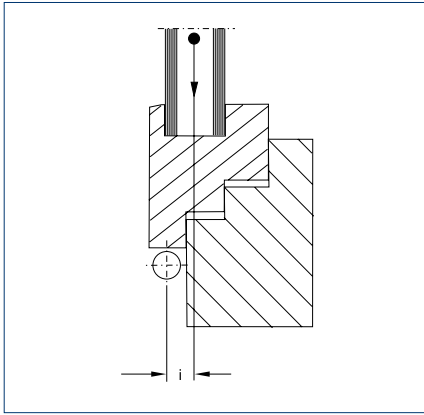

i = Clearance measurement between the leaf's centre of gravity and the hinge pivot point [mm]

**I DIMENSION = 20 - 70**

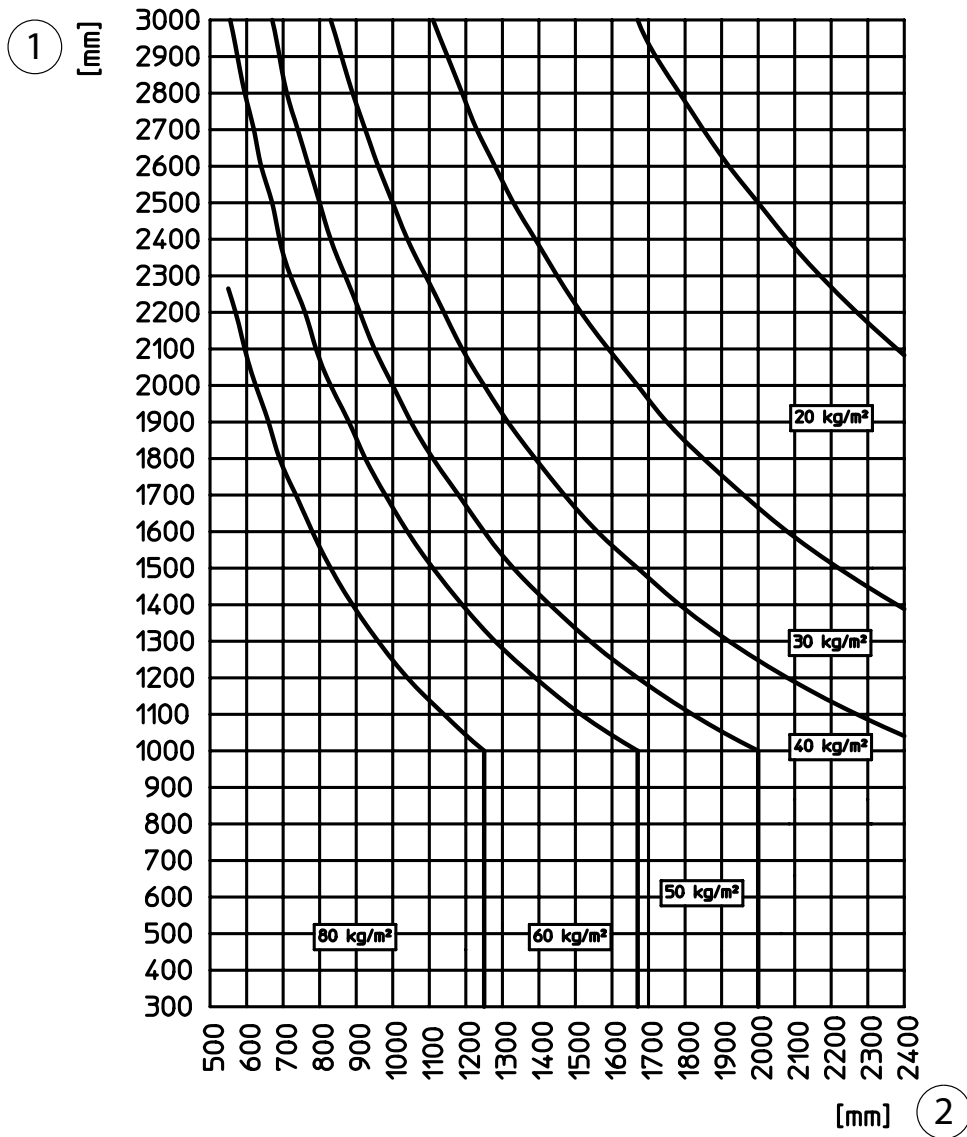

1 = Leaf height | 2 = Leaf width

INSTALLATION

I DIMENSION = 30 - 60

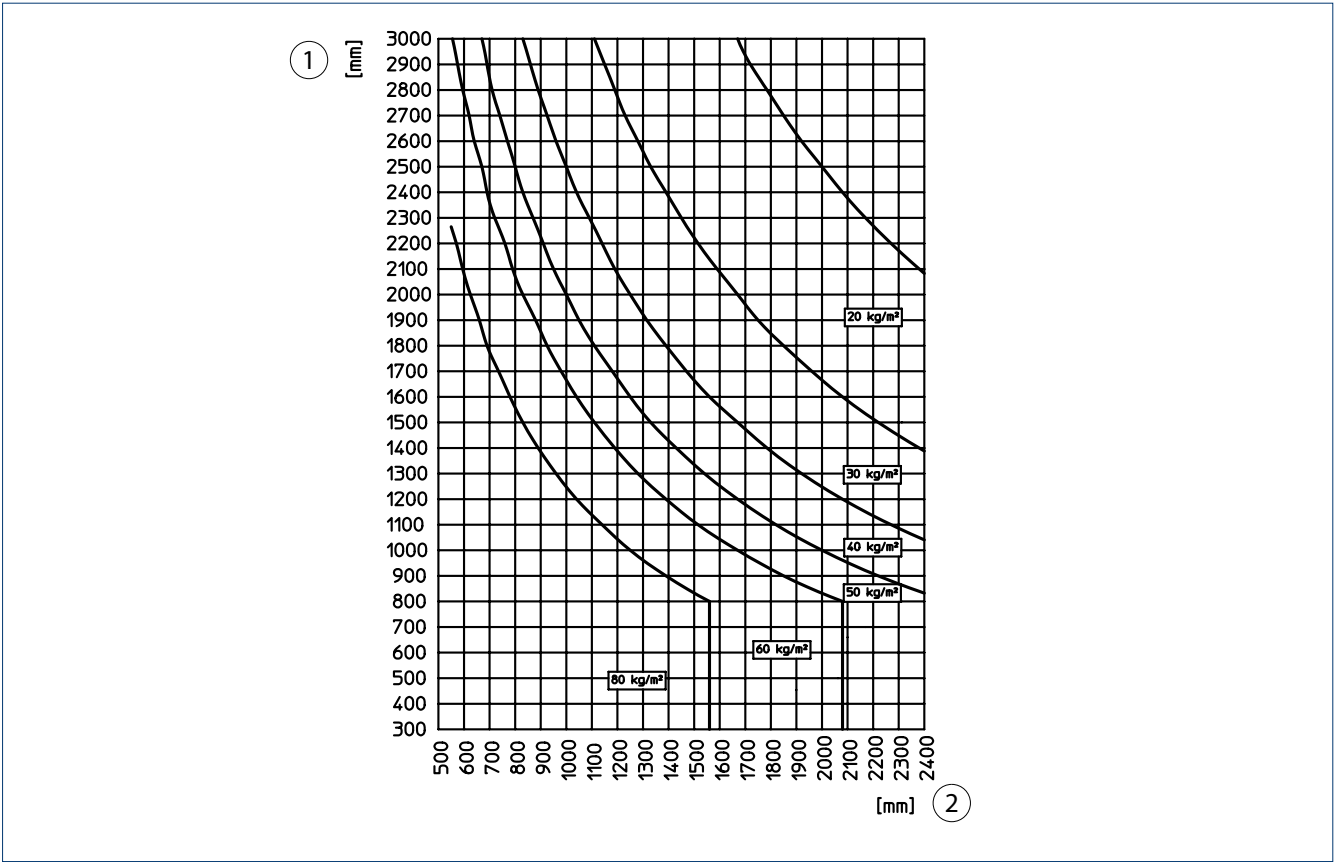

1 = Leaf height | 2 = Leaf width

I DIMENSION = 40 - 50

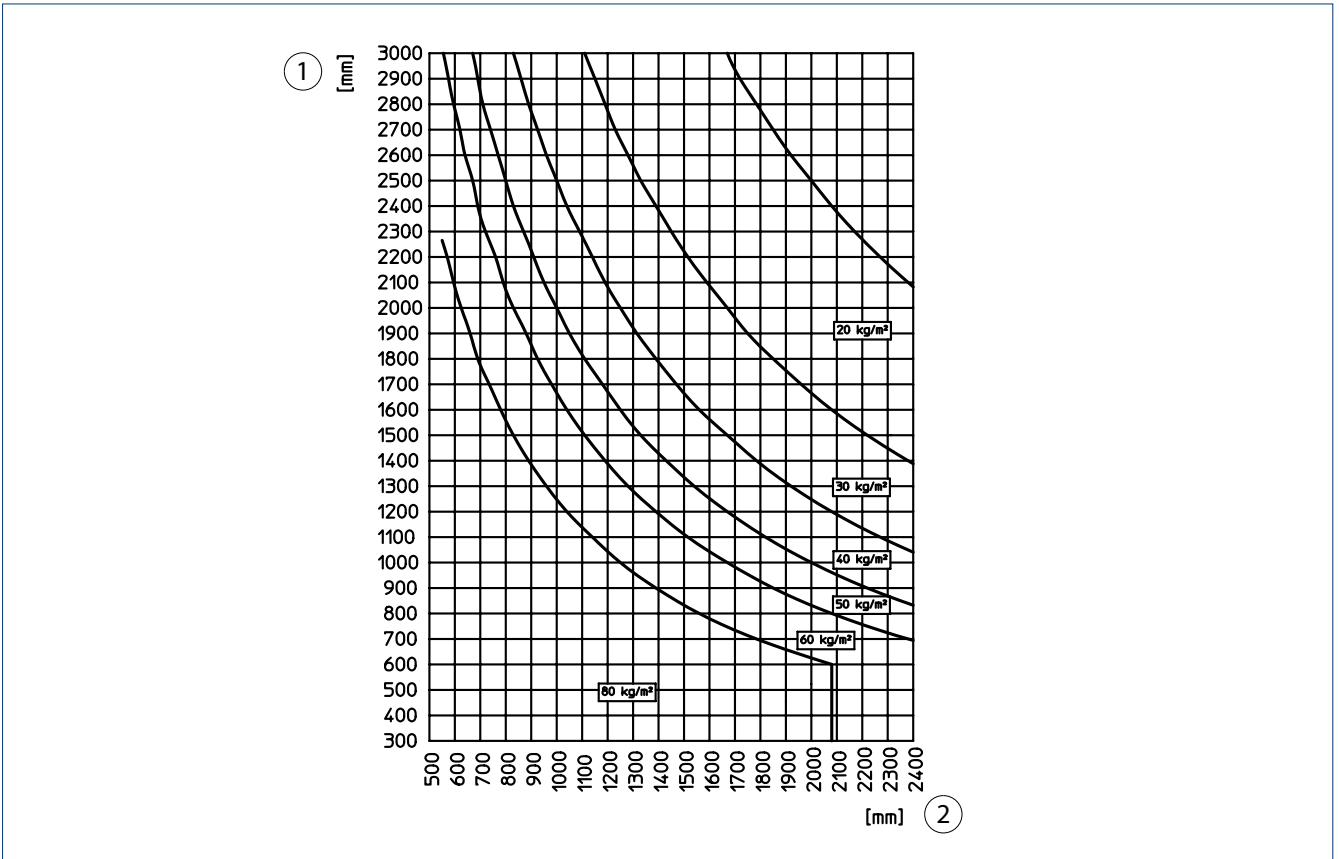

1 = Leaf height | 2 = Leaf width

TYPES OF INSTALLATION

E 170/2 SCISSOR DRIVE

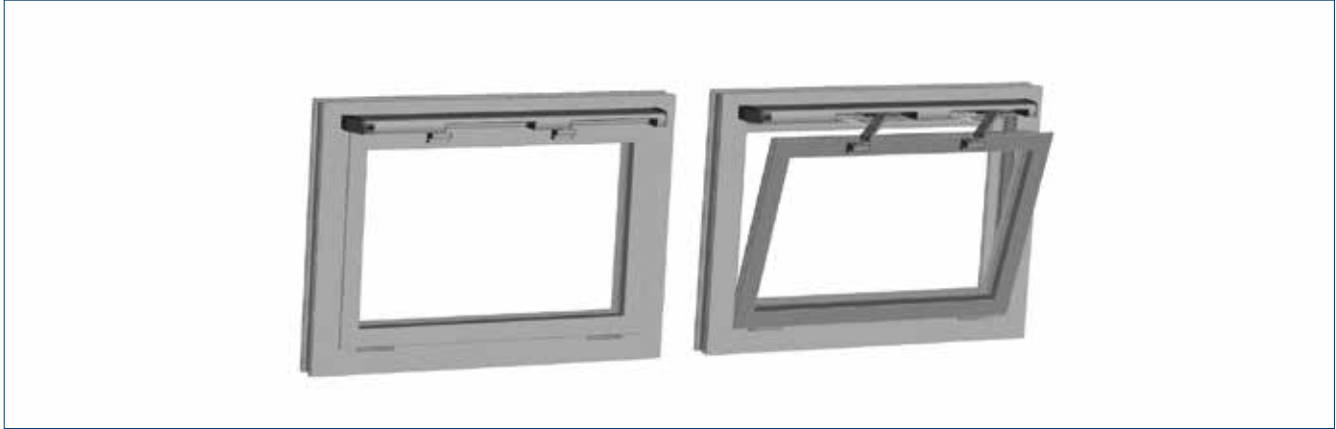

For leaf width 900 – 1600 (1600 – 2400) mm, 2-scissor stay

FITTING DIMENSIONS 170/2 UP TO 1600 MM

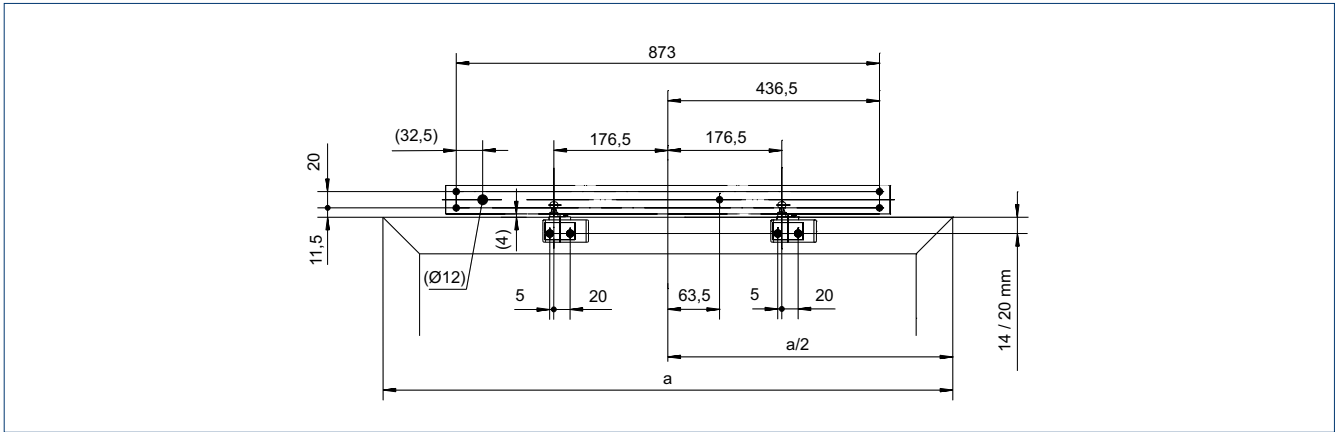

FITTING DIMENSIONS 170/2 UP TO 2400 MM

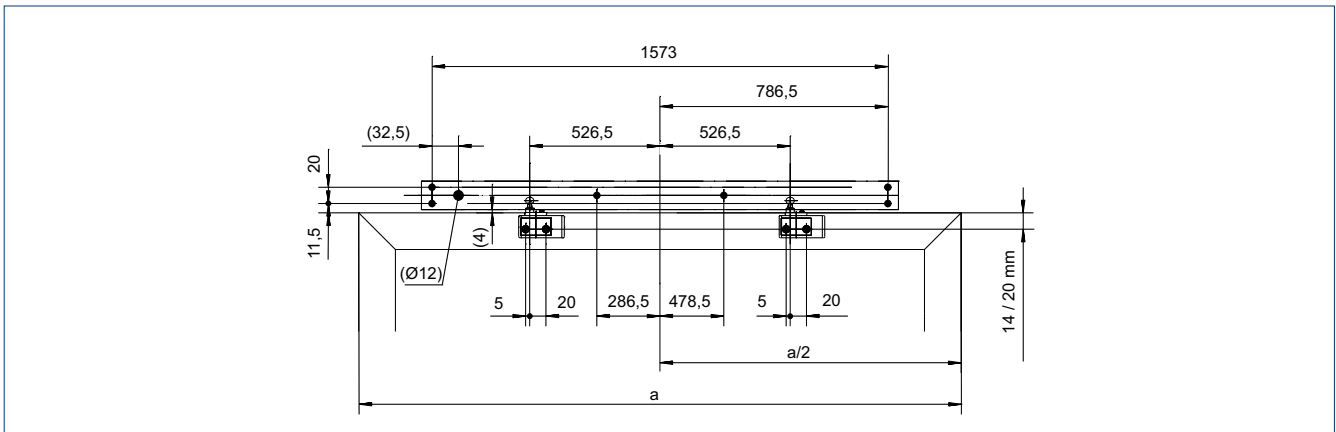



**ORDER INFORMATION**

Designation	Version	ID no.
E 170/2, 230 V to 2400 mm Including leaf bracket	EV1	128720
	white RAL 9016	128721
	according to RAL	128722
E 170/2, 24 V to 2400 mm Including leaf bracket	EV1	128723
	white RAL 9016	128724
	according to RAL	128725
E 170/2, 230 V to 1600 mm Including leaf bracket	EV1	128714
	white RAL 9016	128715
	according to RAL	128716
E 170/2, 24 V to 1600 mm Including leaf bracket	EV1	128717
	white RAL 9016	128718
	according to RAL	128719

**ACCESSORIES**

Standard leaf bracket suitable for E 170	EV1	128925
	white RAL 9016	128926
	according to RAL	128927
Sliding leaf bracket suitable for E 170	EV1	128928
	white RAL 9016	128929
	according to RAL	128930
Variable cover for E 170 The design set for GEZE scissor drives	EV1	128922
	white RAL 9016	128923
	according to RAL	128924
Locking module for E 170 A = 11.5 mm	EV1	128935
	white RAL 9016	128936
	according to RAL	128937
Locking module for E 170 A = 15.5 mm	EV1	128938
	white RAL 9016	128939
	according to RAL	128940
Locking module for E 170 A = 8.5 mm	EV1	128932
	white RAL 9016	128933
	according to RAL	128934

# Variable cover for E 170

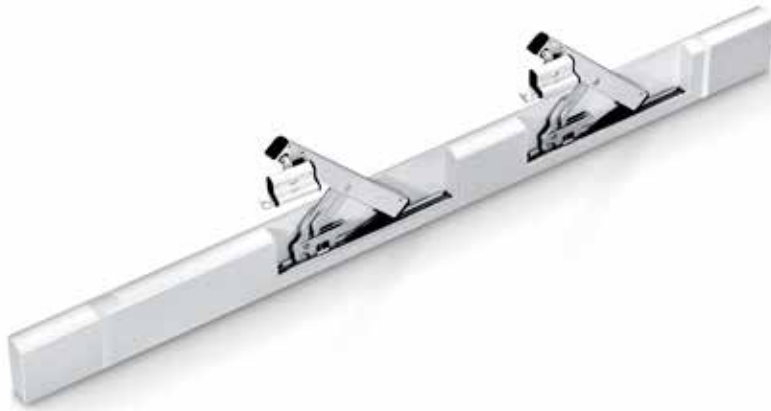

Attractive design and additional protection  
against dirt for GEZE scissor drives

## AREAS OF APPLICATION

- For individual solutions
- Use in post-rail façades

## PRODUCT FEATURES

- Enables a continuous visual appearance and thus creates a uniform appearance

### E 170/2 SCISSOR DRIVES



With variable cover (design set)

### FITTING DIMENSIONS E 170 WITH DESIGN SET

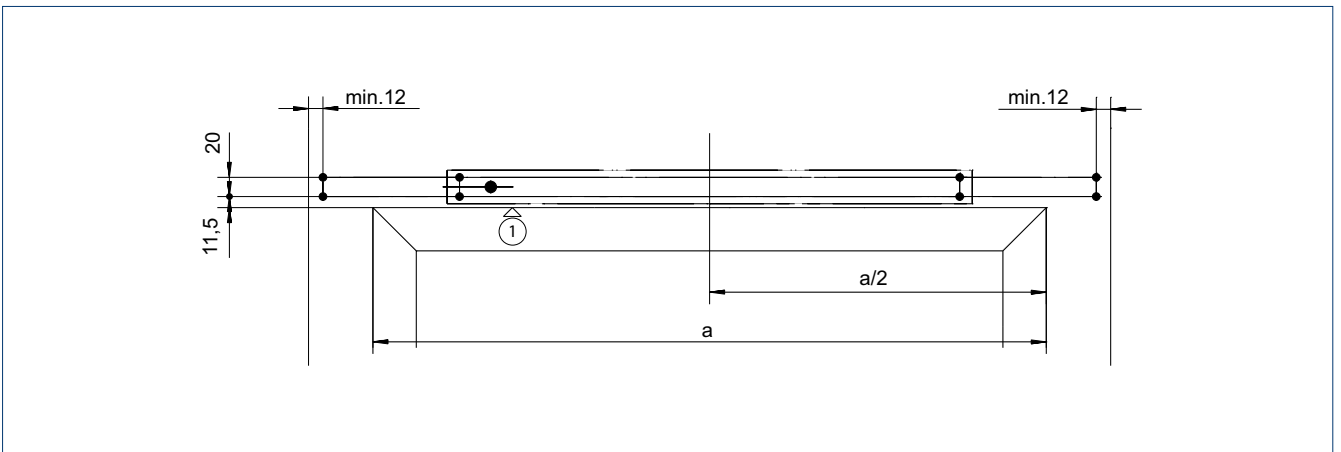

Side limit (e.g. post or jamb) | 1 = Top edge leaf





WINDOW

# Locking drives

Locking drives offer additional safety for your large smoke and heat extraction or ventilation windows. They are the solution for large leaf areas, when locking with the drive's retention force is not sufficient. With additional locking drives, windows can withstand wind load. They provide sealing in the event of pelting rain and are air tight, in addition to providing increased burglar resistance. GEZE also offers locking elements for window ventilation systems with manual fanlight openers for mechanical ventilation.



# Power lock



Locking drive in combination with Slimchain,  
Powerchain or E 250 NT

## AREAS OF APPLICATION

- Additional safety and protection against weather conditions
- Natural ventilation, smoke and heat extraction systems, SHEV according to EN 12101-2
- Can be used in the exhaust air and air intake
- Inward opening windows with bottom-hung, side-hung, top-hung, swing and vertically centre pivoted leaves
- Installation on wooden, PVC or metal windows
- Leaf or frame installation

## PRODUCT FEATURES

- System solution for locking in combination with the IQ windowdrive Slimchain, Powerchain and E 250 NT window drives
- Automatic locking of the window through access to the window transmission
- Meets high requirements for wind load, sealing in the event of rain and air tightness
- Electronic position detection that unlocks the window before opening it
- Electronic end position cut-off provides protection from maloperation and overload
- High tensile and compressive force for up to six locking points
- Locking and unlocking in six seconds
- Synchronization of up to two Power lock and four IQ windowdrive window drives possible
- Tested in combination with IQ windowdrive window drives in accordance with EN 12101-2 (SHEV)

**TECHNICAL DATA**

<b>Power lock</b>		
<b>GENERAL INFORMATION</b>		
Dimensions (W x H x D)	422 mm x 34 mm x 36 mm	
<b>SPECIFICATIONS</b>		
Possible stroke lengths	22 mm	
Opening speed ventilation	3.6 mm/s	
Locking and unlocking time	6 s	
Locking points (max.)	6	
Tensile force (max.)	600 N	
Compressive force (max.)	600 N	
<b>ELECTRICAL DATA</b>		
Operating voltage	24 V ± 25 %	
Current consumption	1.5 A	
Power consumption (max.)	36 W	
Length of power supply cable	2 m	
Special length of power supply cable	5 m, 7.5 m	
Cable dimensions	4 x 0.75 mm <sup>2</sup>	
Temperature range	-5 – 70 °C	
IP rating / protection rating	IP42 / III	
<b>FUNCTIONS</b>		
Stroke length settable	●	
SHEV tested according to EN 12101-2	●	
Microprocessor control unit	integrated	
<b>TYPES OF INSTALLATION</b>		
Bottom-hung window	inward opening	frame / leaf
Side-hung window	inward opening	frame / leaf
Top-hung window	inward opening	frame / leaf
Centre pivoted window	inward opening	frame
Vertically centre pivoted window	inward opening	frame

● = YES

**PRODUCT SCALE DRAWING**

**TYPES OF INSTALLATION**

Frame installation

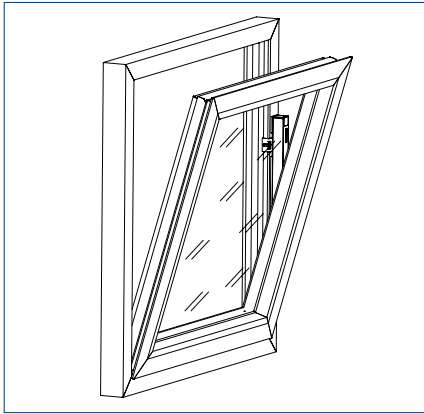

Leaf installation

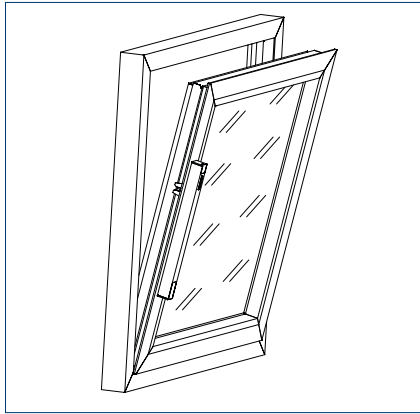

**Note:**

The E 250 NT electric spindle drive (stroke lengths 100 – 300 mm) is installed flush to the profile on the frame using the tried-and-trusted RWA 100 console profile. Locking is achieved using the Power lock locking drive. In less than 60 seconds, the system achieves large opening widths with a small spindle stroke.

**INSTALLATION DIMENSIONS, SPACE NEEDED AND CLOSING DIRECTION**

Installation dimensions frame installation

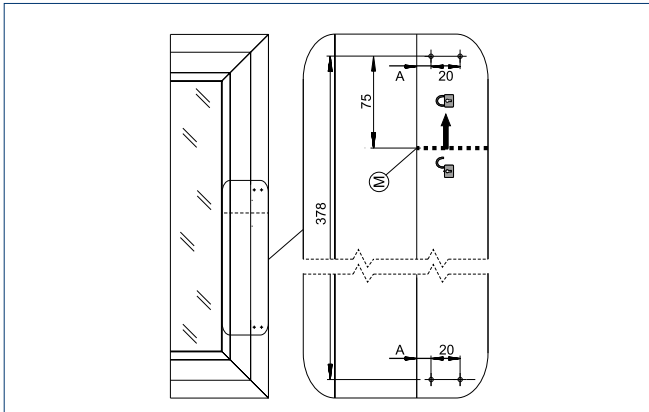

A = Frame installation | M = Unlocked

Installation dimensions leaf installation

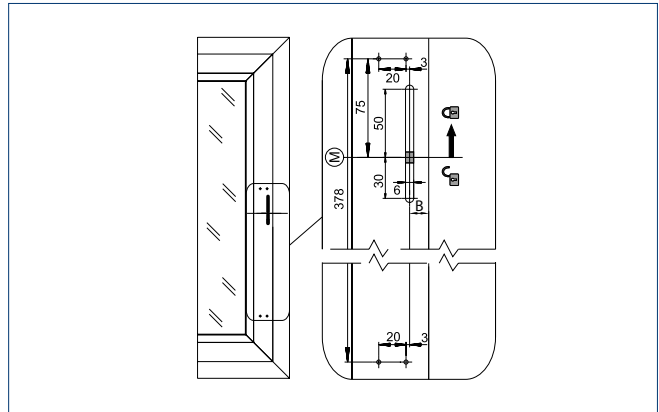

B = Leaf installation | M = Unlocked

Space needed for frame installation

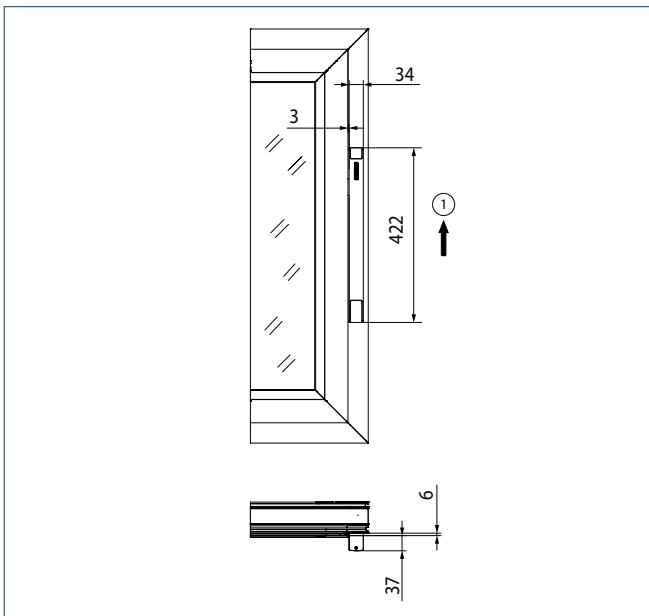

1 = Closing direction

Space needed for leaf installation

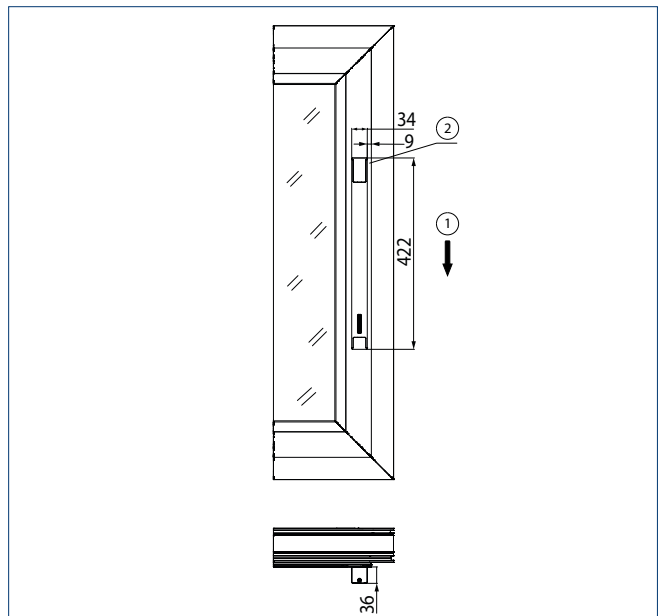

1 = Closing direction | 2 = Height needed: min. 40 mm above and below the drive for line-feed and for loosening the cover caps



Material	Manufacturer	Profile system	Frame installation	Leaf installation
			A	B
Aluminium	Aluprof	MB-60	10	13 <sup>3)</sup>
		MB-70	10	13 <sup>3)</sup>
	Gutmann	S70	9	13 <sup>3)</sup>
	Heroal	065	10	13 <sup>3)</sup>
		110ES	10	13 <sup>3)</sup>
	Hueck	Lambda 65	10	14
		Lambda 77	10	14
	Raico	Frame+ 65 W	10	13 <sup>3)</sup>
		Frame+ 75 WB	10	13 <sup>3)</sup>
SAPA	1074		10	
	1086		10	
Schüco	AWS 65	10	11	
	AWS 75	10	11	
Wicona	Wicline 65 EVO	10	13	
	Wicline 75 EVO	10	13	
Plastic	EgoKiefer	AS1	9	14
	Profine	Kömmerling 88plus	9	15
	Veka	Alphaline 90	9	–
Softline 82 MD		9	–	
Wood	Gutmann	Mira	9	–
	Landgraf	IV79	9	–
	Oertli	IV68 / IV80	9	–

All dimensions in mm.

3 = Only with tapping screws | Further profile ranges on request.

## ORDER INFORMATION

Designation	Dia. of driver	Version	ID no.
Power lock		EV1	147020
Locking stroke max.: 22 mm		white RAL 9016	147021
Power lock		according to RAL	147022
Can be configured: Cable length, colour			

## ACCESSORIES

Installation set leaf	11.5 mm		150505
Driver fork length 35 mm	8.5 mm		147025
Installation set leaf for wooden / PVC windows	11.5 mm		158238
Driver fork length 46 mm			
Frame installation set can be configured as needed: Colour, driver= 8.5 mm / 11.5 mm		according to RAL	150010
Installation set frames	11.5 mm	EV1	150507
	8.5 mm	EV1	147026
	11.5 mm	white RAL 9016	150506
	8.5 mm	white RAL 9016	150508

# Accessories



Installation set leaf (150505)



Installation set frame (150507)

# E 90X



## Integrated locking drive for more safety for large window leaves

### AREAS OF APPLICATION

- Integrated locking drive as system solution in combination with the IQ windowdrive Slimchain, Powerchain and E 250 NT window drives
- Safety and protection against weather conditions even on large windows by means of additional locking device
- For natural ventilation and smoke and heat extraction systems
- Inward opening windows with bottom-hung and side-hung leaves
- Suitable for Schüco AWS TT and Wicona Wicline Evo profile systems, as well as other commercially available systems
- Integrated installation

### PRODUCT FEATURES

- The drive is located in the profile and therefore does not impair the appearance of the window.
- Integrated installation offers additional protection against contamination
- Simple installation without additional profile processing
- Meets high requirements for wind load, sealing in the event of rain and air tightness
- Electronic position detection that unlocks the window before opening it
- Electronic end position cut-off provides protection from maloperation and overload
- High tensile and compressive force for up to six locking points
- Locking and unlocking in five seconds

**TECHNICAL DATA**

<b>E 90X</b>		
<b>GENERAL INFORMATION</b>		
Dimensions (W x H x D)	345 mm x 22 mm x 35 mm	
<b>SPECIFICATIONS</b>		
Possible stroke lengths	18 mm	
Opening speed ventilation	3.6 mm/s	
Locking and unlocking time	5 s	
Locking points (max.)	4	
Tensile force (max.)	400 N	
Compressive force (max.)	400 N	
<b>ELECTRICAL DATA</b>		
Operating voltage	24 V ± 25 %	
Current consumption	1 A	
Power consumption (max.)	22 W	
Duty rating	30 %	
Length of power supply cable	60 mm	
Cable dimensions	4 x 0.75 mm <sup>2</sup>	
Temperature range	-5 – 75 °C	
IP rating / protection rating	IP40/III	
<b>FUNCTIONS</b>		
Overload cut-off	●	
SHEV tested according to EN 12101-2	●	
Microprocessor control unit	integrated	
<b>TYPES OF INSTALLATION</b>		
Bottom-hung window	inward opening	integrated
Side-hung window	inward opening	integrated
Top-hung window	inward opening	integrated
Centre pivoted window	inward opening	integrated
Vertically centre pivoted window	inward opening	integrated

● = YES

**PRODUCT SCALE DRAWING**

Illustration reversed for GEZE E 906

## TYPES OF INSTALLATION

When several locking devices are used, it is not allowed to provide a separate electromechanical drive for each locking device for patent law reasons.

- Minimum leaf height 850 mm
- Installation of max. 2 drives

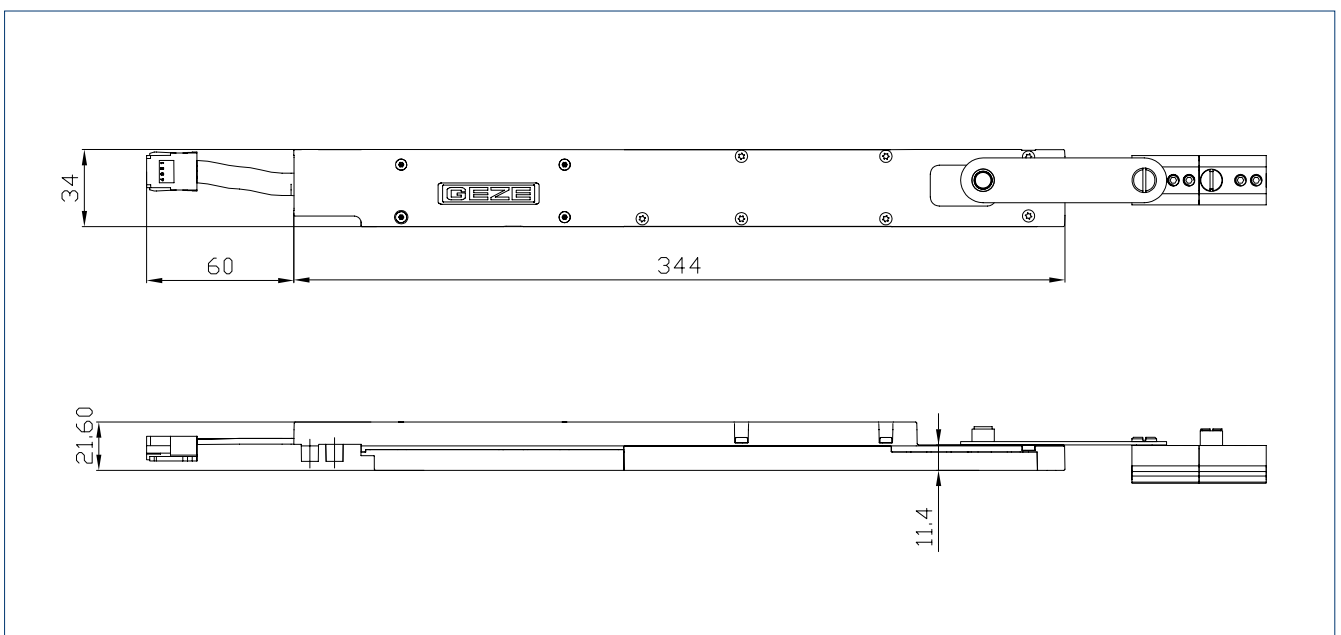
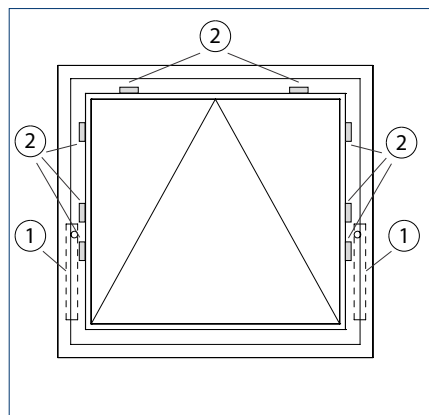

1 = Possible installation variants E 905 / E 906 I  
2 = Possible locking points via central locking

## ORDER INFORMATION

Designation	Stroke	Version	ID no.
E 905 two-point locking drive	18 mm	silver-coloured	143904
E 906 two-point locking drive reversed version of E 905	18 mm	silver-coloured	143905
E 905 locking drive for central closure	18 mm	silver-coloured	161405
E 906 locking drive for central closure mirrored version of the E 905	18 mm	silver-coloured	161406

### ACCESSORIES

Drive bracket E 905	silver-coloured	143906
Drive bracket E 906	silver-coloured	143922
Additional locking device		151672
Connecting link arm 0.5m		151673
Connecting rod 1.0 m		151674
Connecting rod 1.5 m		151675
Flat ribbon cable E 9x0 5 m		141614
Flat ribbon cable E 9x0 50 m		141615
Drip loop MINI 9X0 24 V Schüco AWS		142570
Drip loop E 9X0 24 V Schüco AWS		140822
Connector flat ribbon cable E 9x0 5 pcs.		140631
Connector flat ribbon cable E 9x0 50 pcs.		140632





## WINDOW

# Opening/ locking systems

Smoke-free escape routes in case of fire, thanks to natural smoke and heat extraction and smoke dissipation. Welcome side effect: the function of a window ventilation system for daily ventilation. Smoke and heat extraction opening and locking systems consist of an electric spindle drive and a mechanical fitting set. Large opening widths with a small spindle stroke are achieved in seconds. The systems can be used on all common side-, bottom- and top-hung windows. The drive does not protrude into the room.





# RWA 100 NT



Opening and locking system for inward opening  
bottom-hung, top-hung and side-hung leaves

## AREAS OF APPLICATION

- Opening and locking of inward opening windows with bottom-, top- and side-hung leaves
- Natural ventilation, smoke and heat extraction system, SHEV according to EN 12101-2
- Can be used in the exhaust air and air intake
- Installation on wooden, PVC or metal windows

## PRODUCT FEATURES

- System solution with profile-mounted E 250 NT spindle drive and a console set with locking device
- Mechanical locking at the main closing edge by the spindle drive
- Large opening width with short spindle stroke in less than 60 seconds
- Synchro operation possible with two drives for wide window leaves
- IQ windowdrive - intelligent drive control
- SHEV tested according to EN 12101-2



**TECHNICAL DATA**

**RWA 100 NT**

**GENERAL INFORMATION**

Space needed (min.)	Locking side: 32 mm, Motor side: 48 mm
Permissible dimensions of main closing edge Solo for wooden and aluminium frames	360 - 1200 mm
Permissible dimensions of main closing edge Solo for PVC frames	360 - 800 mm
Permissible dimensions of main closing edge Syncro for wooden and aluminium frames	800 - 2400 mm
Permissible dimensions of main closing edge Syncro for PVC frames	800 - 1600 mm
Leaf heights for Solo and Syncro	520 - 1700 mm

**SPECIFICATIONS**

Possible stroke lengths	100 mm, 150 mm, 200 mm, 300 mm
Tensile force (max.)	750 N
Compressive force (max.)	750 N
Panel weight (max.) <sup>1)</sup>	30 kg/m <sup>2</sup>

**ELECTRICAL DATA**

Operating voltage	24 V DC (+30% to -20%)
Current consumption	Ventilation (24 V): 0.9 A; smoke and heat extraction (18 V): 1.0 A
Power consumption (max.)	20 W
Residual ripple (max.)	30 %
Cable dimensions	4 x 0.75 mm <sup>2</sup>
Temperature range	-5 - 75 °C
IP rating / protection rating	IP65 / III

**FUNCTIONS**

Syncro function	●
Locking device and additional bracket	●
End position cut-off extended	Internal path sensor
End position cut-off retracted	Internal path sensor
Overload cut-off	●

**TYPES OF INSTALLATION**

Bottom-hung window	inward opening	Frame
Side-hung window	inward opening	Frame
Top-hung window	inward opening	Frame

● = YES | 1 = Higher leaf weights possible depending on application and type of installation. Exact calculation with Wincalc necessary.

**SYSTEM STRUCTURE**

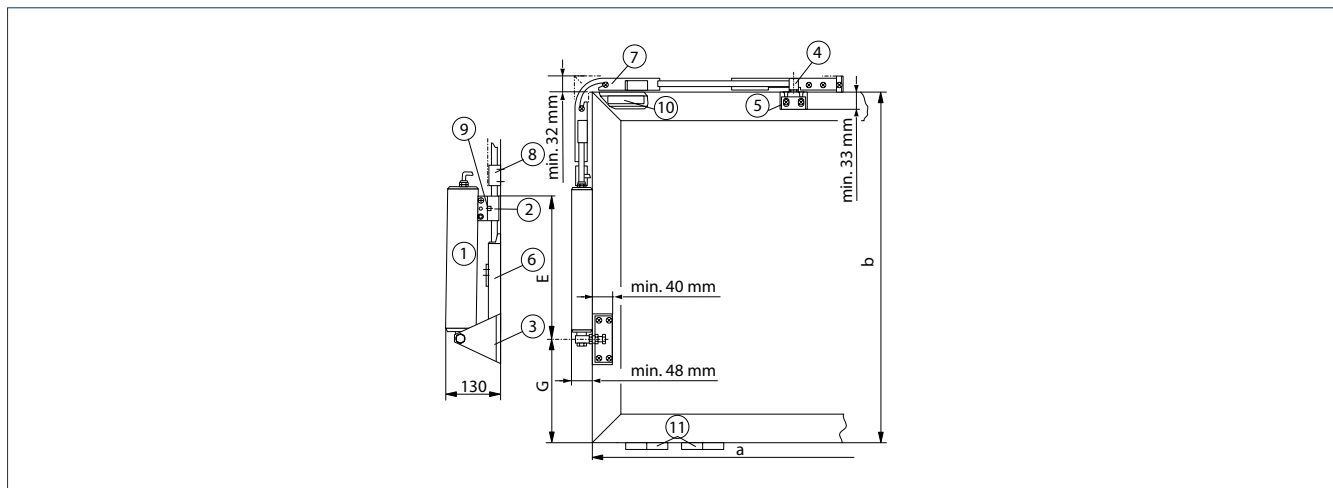

a = Leaf width | b = Leaf height | 1 = E 250 NT electric spindle drive | 2 = Clamping piece | 3 = Toe angle bracket | 4 = Additional locking OL 320 | 5 = Additional bracket complete | 6 = Release spring OL 320 | 7 = Corner transmission OL 320 | 8 = Rod guide OL 320 | 9 = Folding bracket E 250 | 10 = Headstock (on site) - only required for PVC windows | 11 = 2 hinges on the electric drive side (to be provided by customer)

## TYPES OF INSTALLATION

### PROFILE-MOUNTED SYSTEM FOR VERTICALLY INSTALLED INWARD OPENING BOTTOM-HUNG, TOP-HUNG, PITCHED AND SIDE-HUNG WINDOWS.

The given dimensions are standard; please contact GEZE if you require other dimensions.

Details for wooden/aluminium windows

#### RWA 100 NT

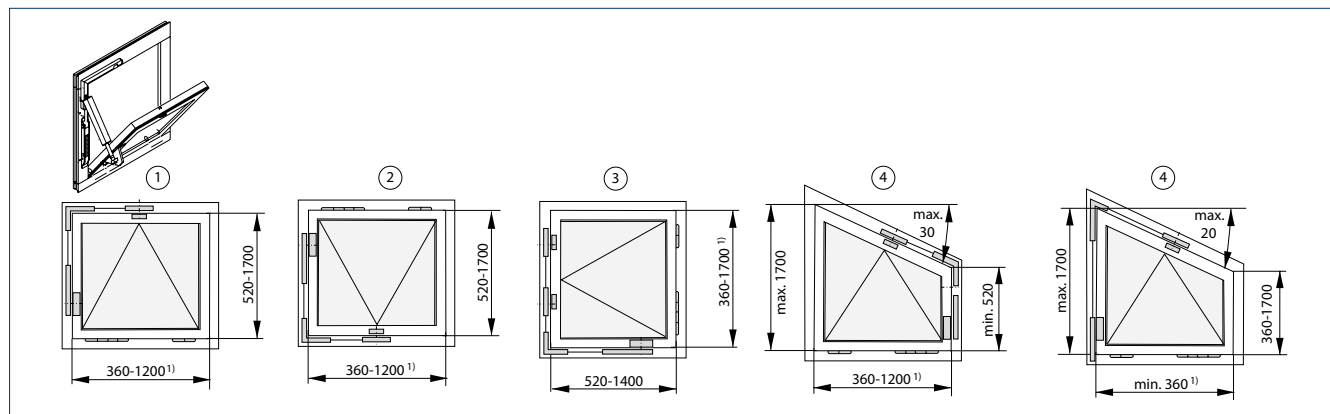

All dimensions in mm

1 = Bottom-hung window | 2 = Top-hung window | 3 = Side-hung window | 4 = Pitched window tilt | <sup>1)</sup> For PVC windows Solo max. 800 mm

#### RWA 100 NT SYNCRO

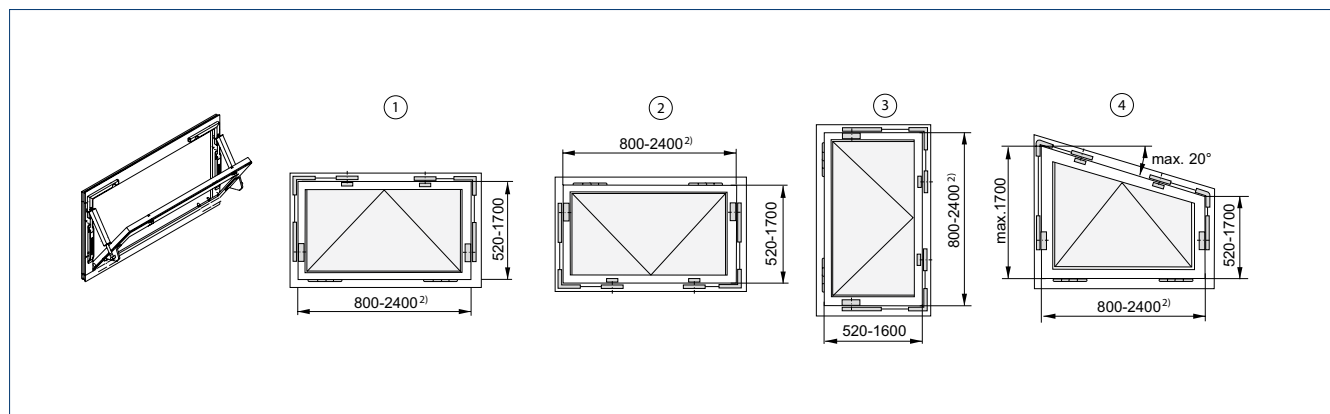

All dimensions in mm

1 = Bottom-hung window | 2 = Top-hung window | 3 = Side-hung window | 4 = Pitched window | <sup>2)</sup> For PVC windows Syncro max. 1600 mm

## DETERMINING THE MOTOR STROKE RWA 100 NT

### RWA 100 NT and RWA 100 NT Syncro:

#### Dimensions

#### Spindle stroke [mm]

Leaf dimension (b) [mm]	520 - 600	600 - 700	700 - 800	800 - 850							100
G dimension [mm]	65	85	125	145							
Opening angle [°]	approx. 34	approx. 32	approx. 28	approx. 26							
Opening width [mm]	approx. 350	approx. 380	approx. 380	approx. 400							
Leaf dimension (b) [mm]	610 - 630	630 - 700	700 - 800	800 - 900	900 - 1000						150
G dimension [mm]	100	115	150	200	275						
Opening angle [°]	approx. 49	approx. 47	approx. 42	approx. 36	approx. 31						
Opening width [mm]	approx. 520	approx. 520	approx. 560	approx. 550	approx. 520						
Leaf dimension (b) [mm]	700 - 720	720 - 800	800 - 900	900 - 1000	1000 - 1100	1100 - 1200	1200 - 1300				200
G dimension [mm]	145	160	215	275	325	425	525				
Opening angle [°]	approx. 58	approx. 55	approx. 47	approx. 41	approx. 37	approx. 31	approx. 27				
Opening width [mm]	approx. 690	approx. 720	approx. 710	approx. 690	approx. 690	approx. 650	approx. 610				
Leaf dimension (b) [mm]	950 - 1000	1000 - 1050	1050 - 1100	1100 - 1150	1150 - 1250	1250 - 1320	1320 - 1400	1400 - 1500	1500 - 1600	1600 - 1700	300
G dimension [mm]	290	335	350	415	465	495	565	645	715	815	
Opening angle [°]	approx. 58	approx. 53	approx. 51	approx. 46	approx. 43	approx. 41	approx. 38	approx. 34	approx. 32	approx. 29	
Opening width [mm]	approx. 970	approx. 930	approx. 950	approx. 900	approx. 900	approx. 920	approx. 890	approx. 870	approx. 860	approx. 830	

## ORDER INFORMATION

Designation	Length	Stroke	Version	ID no.
RWA 100 NT		100 mm	EV1	153187
		150 mm	EV1	153190
		200 mm	EV1	153213
		300 mm	EV1	153216
		100 mm	white RAL 9016	153188
		150 mm	white RAL 9016	153211
		200 mm	white RAL 9016	153214
		300 mm	white RAL 9016	153217
		100 mm	according to RAL	153189
		150 mm	according to RAL	153212
		200 mm	according to RAL	153215
		300 mm	according to RAL	153218
	RWA 100 NT - special version			according to RAL
<b>ACCESSORIES</b>				
Rod Ø 12 mm, without cover profile	2000 mm		galvanised	053198
	3000 mm		galvanised	053199
	6000 mm		galvanised	054116
Cover profile OL 320, length 2000 mm Mitre-cut at both ends			EV1	058771
			white RAL 9016	018293
			according to RAL	014258
Cover profile OL 320 length 3000 mm Mitre-cut at both ends			EV1	058774
			white RAL 9016	018294
			according to RAL	014259
Cover profile OL 320 length 6000 mm Straight-cut at both ends			EV1	058630
			white RAL 9016	018251
			according to RAL	013814
Drilling template for RWA 100E				014740
Additional bracket for overlap height 0 - 12 mm			EV1	050727
			white RAL 9016	015519
			according to RAL	013077
Additional locking device for OL 320 without additional bracket, overlap height 12-25 mm			EV1	063974
			white RAL 9016	018257
			according to RAL	013080
Additional locking device for the secondary closing edge RWA 100E Can be used for OL 350 EN, OL 370 EN, RWA 100E, RWA 110E and OL 320			EV1	120297
			white RAL 9016	120298
			according to RAL	120299
Corner transmission suitable for OL 320			galvanised	058648

### Note:

The E 250 NT electric spindle drive (stroke lengths 100 – 300 mm) is installed flush to the profile on the frame using the tried-and-trusted RWA 100 consoles. Locking is achieved using the Power lock locking drive. In less than 60 seconds, the system achieves large opening widths with small spindle stroke.

# OL 350 EN



Opening and locking system for inward opening bottom-hung, top-hung, pitched and side-hung windows

## AREAS OF APPLICATION

- Natural ventilation (230 V)
- Opening and locking of inward opening windows with bottom-, top- and side-hung leaves
- Installation on wooden, PVC or metal windows

## PRODUCT FEATURES

- System solution with profile-mounted E 350 N spindle drive and a console set with locking device
- Mechanical locking at the main closing edge by the spindle drive
- Large opening widths with small spindle stroke
- Only Solo operation possible

**TECHNICAL DATA**

**OL 350 EN**

**GENERAL INFORMATION**

Space needed (min.)	locking side: 32 mm, motor side: 48 mm
Permissible dimensions of main closing edge Solo for wooden and aluminium frames	360 – 1200 mm
Permissible dimensions of main closing edge Solo for PVC frames	360 – 800 mm
Leaf heights	520 – 1700 mm

**SPECIFICATIONS**

Possible stroke lengths	100 mm, 150 mm, 200 mm, 300 mm
Tensile force (max.)	750 N
Compressive force (max.)	750 N
Panel weight (max.) <sup>1)</sup>	30 kg/m <sup>2</sup>

**ELECTRICAL DATA**

Operating voltage	230V AC
Current consumption	0.15 A
Power consumption (max.)	35 W
Cable dimensions	3 x 0.75 mm <sup>2</sup>
Temperature range	-20 – 70 °C
IP rating / protection rating	IP65 / II

**FUNCTIONS**

Locking device and additional bracket	●
End position cut-off extended	electromechanical
End position cut-off retracted	electromechanical
Overload cut-off	●

**TYPES OF INSTALLATION**

Bottom-hung window	inward opening	frame
Side-hung window	inward opening	frame
Top-hung window	inward opening	frame

● = YES | 1 = Higher leaf weights possible depending on application and type of installation. Exact calculation with Wincalc necessary.

**SYSTEM STRUCTURE**

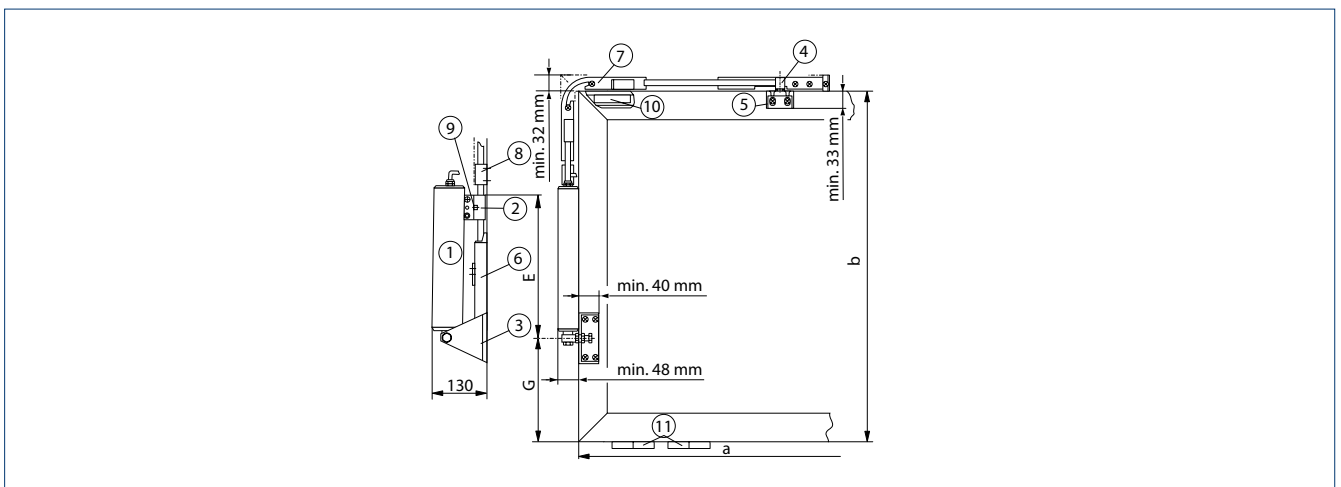

For details of fitting dimensions G and E, see table  
 a = Leaf width | b = Leaf height | 1 = E 350 N electric spindle drive | 2 = Clamping piece | 3 = Toe angle bracket | 4 = Additional locking OL 320 | 5 = Additional bracket complete  
 I 6 = Release spring OL 320 | 7 = Corner transmission OL 320 | 8 = Rod guide OL 320 | 9 = Folding bracket E 350 N | 10 = Headstock (on site) – only required for PVC windows |  
 11 = 2 hinges on the electric drive side (to be provided by customer)

## TYPES OF INSTALLATION

### PROFILE-MOUNTED SYSTEM FOR VERTICALLY INSTALLED INWARD OPENING BOTTOM-HUNG, TOP-HUNG, PITCHED AND SIDE-HUNG WINDOWS.

The given dimensions are standard; please contact GEZE if you require other dimensions.

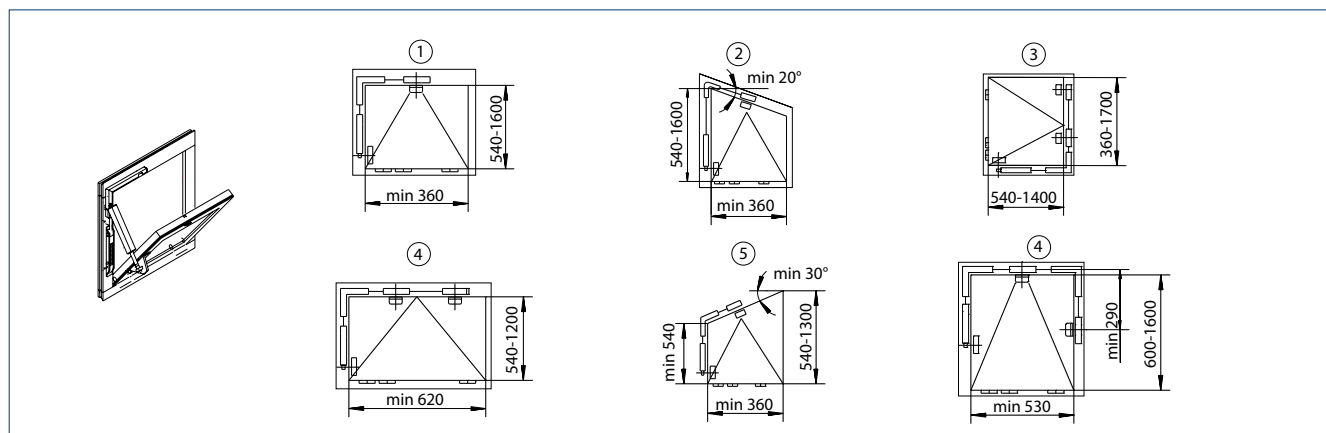

All dimensions in mm

1 = Bottom-hung window | 2 = Pitched window tilt | 3 = Side-hung window (>620 mm with 2 locks) | 4 = Bottom-hung window | 5 = Pitched window tilt (not with drive stroke 300 mm) | 6 = Bottom-hung window

### FITTING DIMENSIONS G AND E DEPENDING ON MOTOR STROKE AND LEAF HEIGHTS

OL 350 EN Solo	Leaf height (b)	Dimension G	Dimension E	Opening angle	Opening width
Stroke 100 mm	540 – 650* mm	65 mm	367 mm	approx. 37°	approx. 380 mm
	650 – 750 mm	110 mm	367 mm	approx. 32°	approx. 380 mm
	750 – 850 mm	150 mm	367 mm	approx. 28°	approx. 390 mm
	850 – 950 mm	200 mm	367 mm	approx. 25°	approx. 390 mm
Stroke 150 mm	660 – 700* mm	125 mm	417 mm	approx. 47°	approx. 550 mm
	700 – 800* mm	170 mm	417 mm	approx. 41°	approx. 530 mm
	800 – 900 mm	230 mm	417 mm	approx. 36°	approx. 530 mm
	900 – 1000 mm	280 mm	417 mm	approx. 32°	approx. 530 mm
	1000 – 1500 mm	340 mm	417 mm	approx. 28°	approx. 530 mm
Stroke 200 mm	850 – 900* mm	250 mm	468 mm	approx. 45°	approx. 670 mm
	900 – 1000* mm	310 mm	468 mm	approx. 40°	approx. 640 mm
	1000 – 1100 mm	370 mm	468 mm	approx. 36°	approx. 640 mm
	1100 – 1200 mm	440 mm	468 mm	approx. 32°	approx. 630 mm
	1200 – 1300 mm	530 mm	468 mm	approx. 28°	approx. 610 mm
Stroke 300 mm	1150 – 1200* mm	470 mm	568 mm	approx. 43°	approx. 880 mm
	1200 – 1250* mm	525 mm	568 mm	approx. 41°	approx. 850 mm
	1250 – 1300* mm	575 mm	568 mm	approx. 38°	approx. 840 mm
	1300 – 1350* mm	625 mm	568 mm	approx. 36°	approx. 820 mm
	1350 – 1400* mm	675 mm	568 mm	approx. 34°	approx. 800 mm
	1400 – 1450* mm	725 mm	568 mm	approx. 32°	approx. 790 mm
	1450 – 1500* mm	775 mm	568 mm	approx. 30°	approx. 780 mm
	1500 – 1550* mm	825 mm	568 mm	approx. 29°	approx. 780 mm
	1550 – 1600* mm	875 mm	568 mm	approx. 28°	approx. 770 mm

\* Shorten corner transmission by 50 mm

## ORDER INFORMATION

Designation	Stroke	Version	ID no.
OL 350 EN opening and locking system	100 mm	EV1	087920
	150 mm	EV1	087925
	200 mm	EV1	087930
	300 mm	EV1	087935
	100 mm	white RAL 9016	087923
	150 mm	white RAL 9016	087928
	200 mm	white RAL 9016	087933
	300 mm	white RAL 9016	087938

# RWA 105 NT



## Opening and locking system for post-rail constructions

### AREAS OF APPLICATION

- Natural ventilation, smoke and heat extraction system and SHEV according to EN 12101-2
- Opening and locking of inward opening windows with bottom-, top- and side-hung leaves in post-rail façades
- Installation on wooden, PVC or metal windows

### PRODUCT FEATURES

- System solution with profile-mounted E 250 NT spindle drive and a console set with locking device
- Double mechanical locking at the main closing edge by the spindle drive
- Very few space needed on the frame
- Large opening width with short spindle stroke in less than 60 seconds
- Synchro operation possible with two drives for wide window leaves
- IQ windowdrive - intelligent drive control
- SHEV tested according to EN 12101-2

## TECHNICAL DATA

### RWA 105 NT

#### GENERAL INFORMATION

Space needed (min.)	cover frame: 18 mm, leaf: 38 mm, post-rail height max. 125 mm
Permissible dimensions of main closing edge Solo for wooden and aluminium frames	depending on stroke
Permissible dimensions of main closing edge Solo for PVC frames	depending on stroke
Permissible dimensions of main closing edge Syncro for wooden and aluminium frames	depending on stroke
Permissible dimensions of main closing edge Syncro for PVC frames	depending on stroke
Leaf heights for Solo and Syncro	depending on stroke

#### SPECIFICATIONS

Possible stroke lengths	100 mm, 150 mm, 230 mm
Tensile force (max.)	750 N
Compressive force (max.)	750 N
Panel weight (max.) <sup>1)</sup>	30 kg/m <sup>2</sup>

#### ELECTRICAL DATA

Operating voltage	24 V DC (+30% to -20%)
Current consumption	ventilation (24 V): 0.9 A; smoke and heat extraction (18 V): 1.0 A
Power consumption (max.)	20 W
Residual ripple (max.)	30 %
Cable dimensions	4 x 0.75 mm <sup>2</sup>
Temperature range	-5 – 75 °C
IP rating / protection rating	IP65 / III

#### FUNCTIONS

Syncro function	●
Locking device and additional bracket	●
End position cut-off extended	internal path sensor
End position cut-off retracted	internal path sensor
Overload cut-off	●

#### TYPES OF INSTALLATION

Bottom-hung window	inward opening	leaf
Side-hung window	inward opening	leaf
Top-hung window	inward opening	leaf

● = YES | 1 = Higher leaf weights possible depending on application and type of installation. Exact calculation with Wincalc necessary.

## SYSTEM STRUCTURE

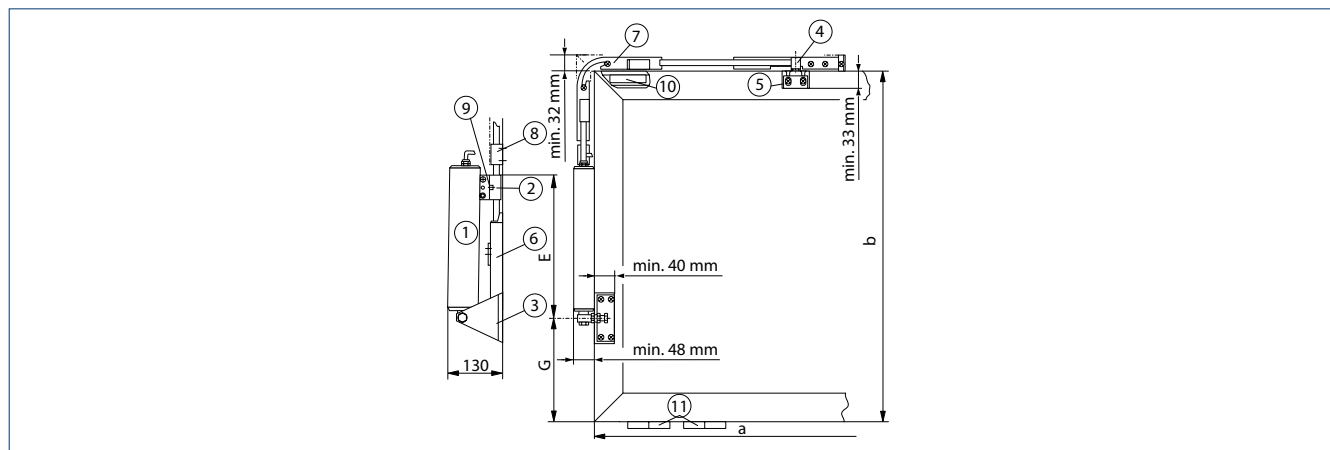

a = Leaf height | b = Leaf width | 1 = E 250 NT electric spindle drive | 2 = Corner transmission RWA 105E | 3 = Locking device RWA 105E | 4 = Cover rail RWA 105E, lift 230 mm | 5 = Unlocking panel RWA 105E | 6 = Console RWA 105E | 7 = Console support RWA 105E | 8 = Rod guide | 9 = Drive bearing pin | 10 = rod ø 12, galvanized | 11 = Outer edge of leaf | 12 = 2 hinges on the electric drive side (to be provided by customer)



## TYPES OF INSTALLATION

### PROFILE-MOUNTED SYSTEM FOR VERTICALLY INSTALLED, RECTANGULAR INWARD OPENING BOTTOM-, TOP- AND SIDE-HUNG WINDOWS

The given dimensions are standard; please contact GEZE if you require other dimensions.

Details for wooden/aluminium windows

#### RWA 105 NT

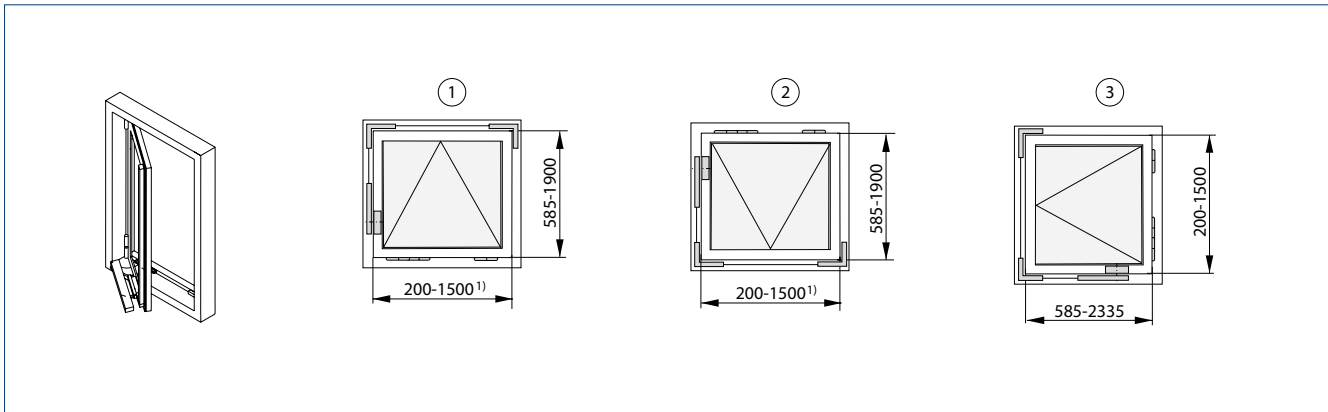

All dimensions in mm

1 = Bottom-hung window | 2 = Top-hung window | 3 = Side-hung window | <sup>1)</sup> For PVC windows Solo max. 800 mm

#### RWA 105 NT SYNCRO

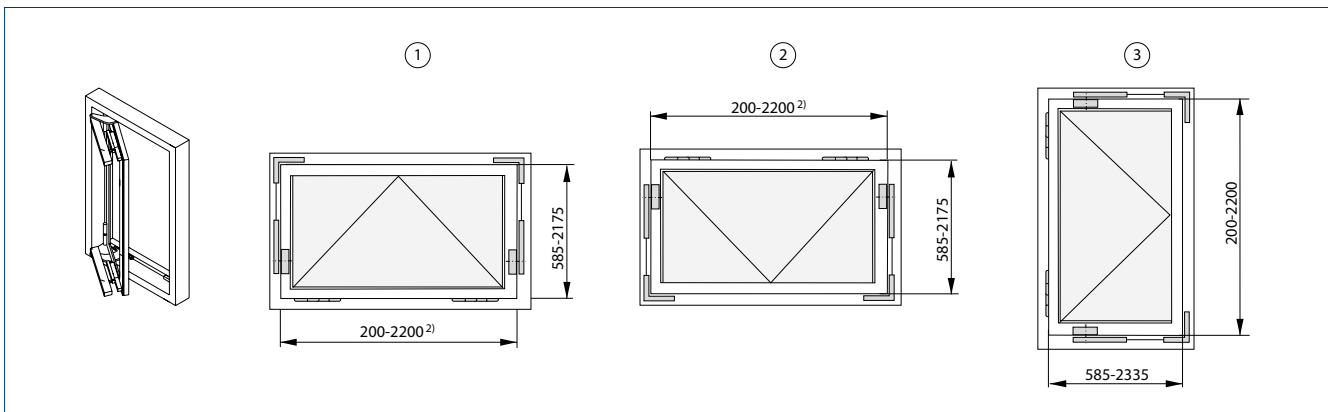

All dimensions in mm

1 = Bottom-hung window | 2 = Top-hung window | 3 = Side-hung window | <sup>1)</sup> For PVC windows Syncro max. 1600 mm

Determining the-opening width (ÖW)

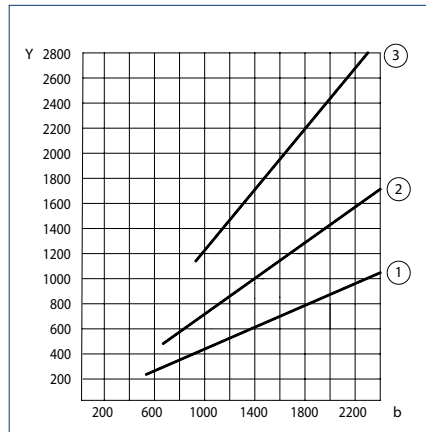

Y = Opening angle (mm) | b = Leaf height (bottom-hung leaf)/Leaf width (side-hung window) (mm) |  
 1 = Stroke 100 ÖW-25° | 2 = Stroke 150 ÖW-40° |  
 3 = Stroke 230 ÖW-75°

Determining the Solo motor stroke

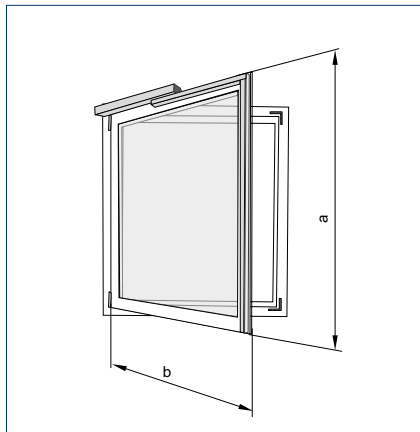

a = Leaf height | b = Leaf width

Determining the Syncro motor stroke

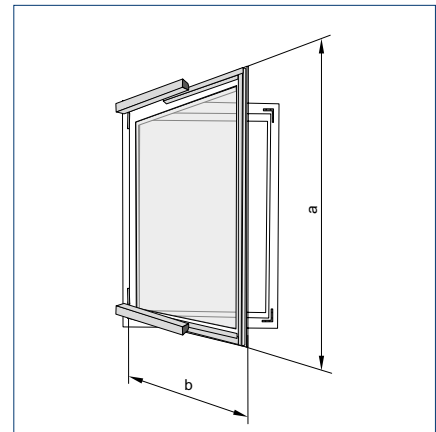

a = Leaf height | b = Leaf width

DETERMINATION OF THE MOTOR STROKE

RWA 105 NT SOLO

Permissible leaf format stroke 100 mm

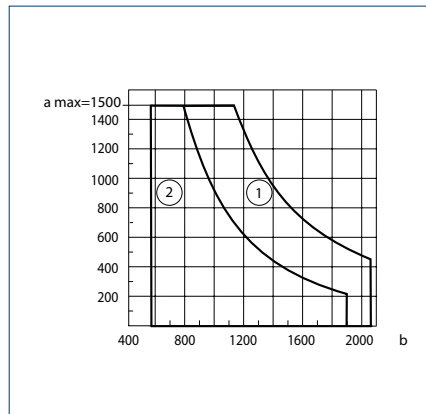

a max. = 1500 mm | b min. = 585 mm | b max. = 2075 mm |  
 1 = Side-hung window | 2 = Bottom-hung/top-hung window

Permissible leaf format stroke 150 mm

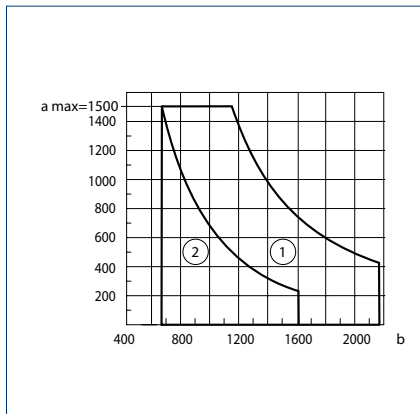

a max. = 1500 mm | b min. = 685 mm | b max. = 2175 mm |  
 1 = Side-hung window | 2 = Bottom/top-hung window

Permissible leaf format stroke 230 mm

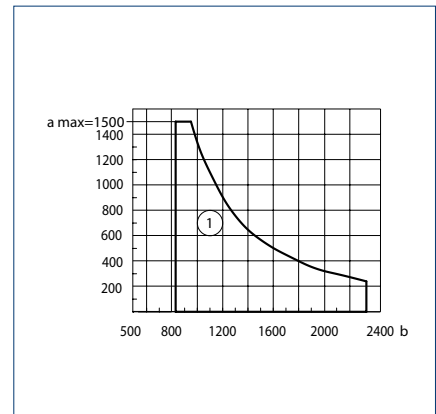

a max. = 1500 mm | b min. = 845 mm | b max. = 2335 mm |  
 1 = Side-hung window

RWA 105 NT SYNCRO

Permissible leaf format stroke 100 mm

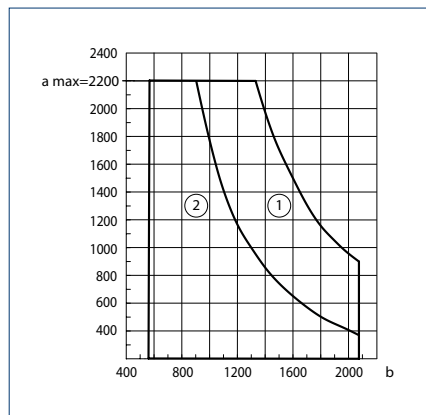

a max. = 2200 mm | b min. = 585 mm | b max. = 2075 mm |  
 1 = Side-hung window | 2 = Bottom-hung/top-hung window

Permissible leaf format stroke 150 mm

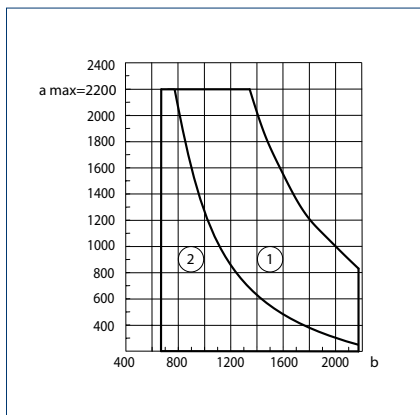

a max. = 2200 mm | b min. = 685 mm | b max. = 2175 mm |  
 1 = Side-hung window | 2 = Bottom-hung/top-hung window

Permissible leaf format stroke 230 mm

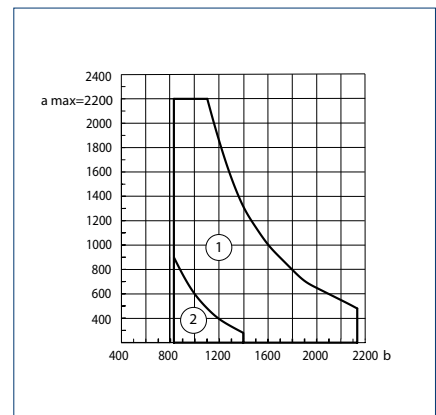

a max. = 2200 mm | b min. = 845 mm | b max. = 2335 mm |  
 1 = Side-hung window | 2 = Bottom-hung/top-hung window

**ORDER INFORMATION**

Designation	Length	Stroke	Version	ID no.
RWA 105 NT		100 mm	EV1	153230
		100 mm	white RAL 9016	153231
		100 mm	according to RAL	153232
		150 mm	EV1	153233
		150 mm	white RAL 9016	153234
		150 mm	according to RAL	153235
		230 mm	EV1	153236
		230 mm	white RAL 9016	153237
		230 mm	according to RAL	153238
RWA 105 NT - special version				153239
RWA 105 NT SYNCRO contains 2 E 250 NT drives		100 mm	EV1	153640
		100 mm	white RAL 9016	153661
		100 mm	according to RAL	153662
		150 mm	EV1	153663
		150 mm	white RAL 9016	153664
		150 mm	according to RAL	153665
		230 mm	EV1	153666
		230 mm	white RAL 9016	153667
		230 mm	according to RAL	153668
RWA 105 NT SYNCRO - special version Can be configured: stroke, cable length, colour; contains 2 E 250 NT drives				153669
Rod Ø 12 mm, without cover profile	2000 mm		galvanised	053198
	3000 mm		galvanised	053199
	6000 mm		galvanised	054116
Cover profile OL 320, length 2000 mm Mitre-cut at both ends			EV1	058771
			white RAL 9016	018293
			according to RAL	014258
Cover profile OL 320 length 3000 mm Mitre-cut at both ends			EV1	058774
			white RAL 9016	018294
			according to RAL	014259
Cover profile OL 320 length 6000 mm Straight-cut at both ends			EV1	058630
			white RAL 9016	018251
			according to RAL	013814
<b>ACCESSORIES</b>				
Rod guide				058653

# OL 370 EN



## Opening and locking system for post-rail constructions and side-hung windows

### AREAS OF APPLICATION

- Natural ventilation (230 V) in post-rail constructions
- Inward opening windows with bottom-, top- and side-hung leaves
- Installation on wooden, PVC or metal windows

### PRODUCT FEATURES

- System solution with profile-mounted E 350 N spindle drive and a console set with locking device
- Double mechanical locking increases tightness and burglary protection
- Very few space needed on the frame
- Large opening widths with small spindle stroke
- Only Solo operation possible

## TECHNICAL DATA

### OL 370 EN

#### GENERAL INFORMATION

Space needed (min.)	cover frame: 18 mm, leaf: 38 mm, post-rail height max. 125 mm
Permissible dimensions of main closing edge Solo for wooden and aluminium frames	depending on stroke
Permissible dimensions of main closing edge Solo for PVC frames	depending on stroke
Leaf heights	depending on stroke

#### SPECIFICATIONS

Possible stroke lengths	150 mm, 230 mm
Tensile force (max.)	750 N
Compressive force (max.)	750 N
Panel weight (max.) <sup>1)</sup>	30 kg/m <sup>2</sup>

#### ELECTRICAL DATA

Operating voltage	230V AC
Current consumption	0.15 A
Power consumption (max.)	35 W
Cable dimensions	3 x 1.5 mm <sup>2</sup>
Temperature range	-20 – 70 °C
IP rating / protection rating	IP65 / II

#### FUNCTIONS

Locking device and additional bracket	●
End position cut-off extended	electromechanical
End position cut-off retracted	electromechanical
Overload cut-off	●

#### TYPES OF INSTALLATION

Bottom-hung window	inward opening	leaf
Side-hung window	inward opening	leaf
Top-hung window	inward opening	leaf

● = YES | 1 = Higher leaf weights possible depending on application and type of installation. Exact calculation with Wincalc necessary.

## SYSTEM STRUCTURE

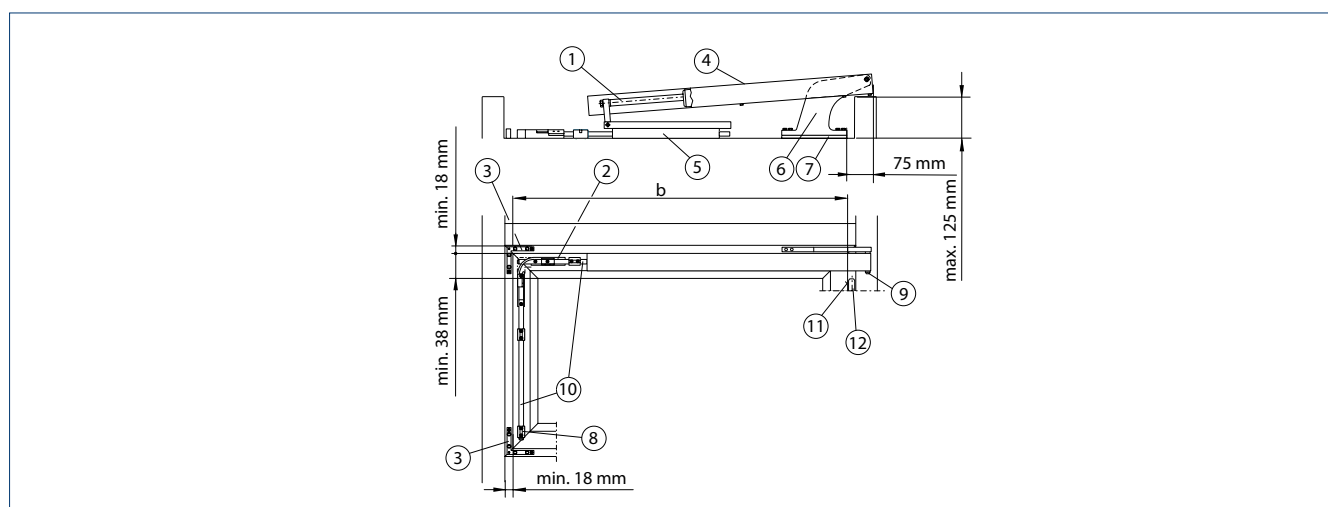

b = Leaf width | 1 = E 350 N spindle drive | 2 = Corner transmission | 3 = Locking device | 4 = Cover rail, stroke 230 mm | 5 = Unlocking field | 6 = Console | 7 = Console support | 8 = Rod guide | 9 = Drive bearing pin | 10 = Rod ø 12, galvanised | 11 = Outer leaf edge | 12 = 2 hinges on the electric drive side (to be provided by the customer)

## TYPES OF INSTALLATION

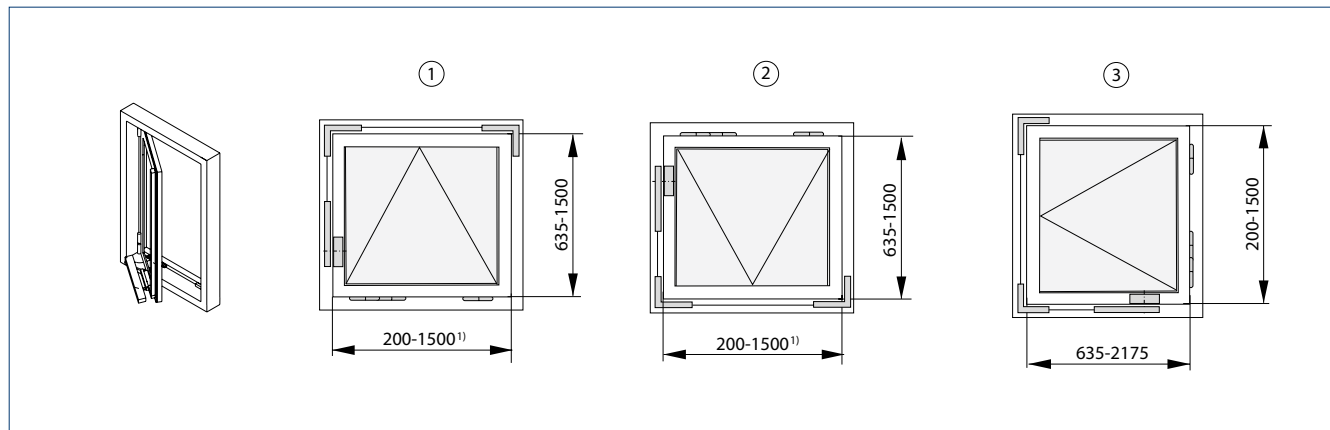

All dimensions in mm

1 = Bottom-hung window | 2 = Top-hung window | 3 = Side-hung window | <sup>1)</sup> For PVC windows Solo max. 800 mm

## ORDER INFORMATION

Designation	Stroke	Version	ID no.
GEZE OL 370 EN	150 mm	EV1	088139
	150 mm	white RAL 9016	088142
	230 mm	EV1	088144
	230 mm	white RAL 9016	088147

# RWA 110 NT



Opening and locking system for outward opening bottom-hung, top-hung and side-hung leaves

## AREAS OF APPLICATION

- Opening and locking of outward opening windows
- Natural ventilation, smoke and heat extraction system, SHEV according to EN 12101-2
- Can be used in the exhaust air and air intake
- Outward opening windows with bottom-, top- and side-hung leaves
- Installation on wooden, PVC or metal windows

## PRODUCT FEATURES

- System solution with profile-mounted E 250 NT spindle drive and a console set with locking device
- Mechanical locking at the main closing edge by the spindle drive
- Large opening width with short spindle stroke in less than 60 seconds
- Synchro operation possible with two drives for wide window leaves
- IQ windowdrive - intelligent drive control
- SHEV tested according to EN 12101-2

## TECHNICAL DATA

### RWA 110 NT

#### GENERAL INFORMATION

Space needed (min.)	leaf frame: min. 33 mm, cover frame: min. 45 mm
Permissible dimensions of main closing edge Solo for wooden and aluminium frames	430 – 1200 mm
Permissible dimensions of main closing edge Solo for PVC frames	430 – 800 mm
Permissible dimensions of main closing edge Syncro for wooden and aluminium frames	850 – 2400 mm
Permissible dimensions of main closing edge Syncro for PVC frames	850 – 1600 mm
Clear frame height for Solo and Syncro	600 – 1600 mm

#### SPECIFICATIONS

Possible stroke lengths	150 mm, 200 mm, 300 mm
Tensile force (max.)	750 N
Compressive force (max.)	750 N
Panel weight (max.) <sup>1)</sup>	30 kg/m <sup>2</sup>

#### ELECTRICAL DATA

Operating voltage	24 V DC (+30% to -20%)
Current consumption	ventilation (24 V): 0.9 A; smoke and heat extraction (18 V): 1.0 A
Power consumption (max.)	20 W
Residual ripple (max.)	30 %
Cable dimensions	4 x 0.75 mm <sup>2</sup>
Temperature range	-5 – 75 °C
IP rating / protection rating	IP65 / III

#### FUNCTIONS

Syncro function	●
Locking device and additional bracket	●
End position cut-off extended	internal path sensor
End position cut-off retracted	internal path sensor
Overload cut-off	●

#### TYPES OF INSTALLATION

Bottom-hung window	outward opening	leaf
Side-hung window	outward opening	leaf
Top-hung window	outward opening	leaf

● = YES | 1 = Higher leaf weights possible depending on application and type of installation. Exact calculation with Wincalc necessary.

## SYSTEM STRUCTURE

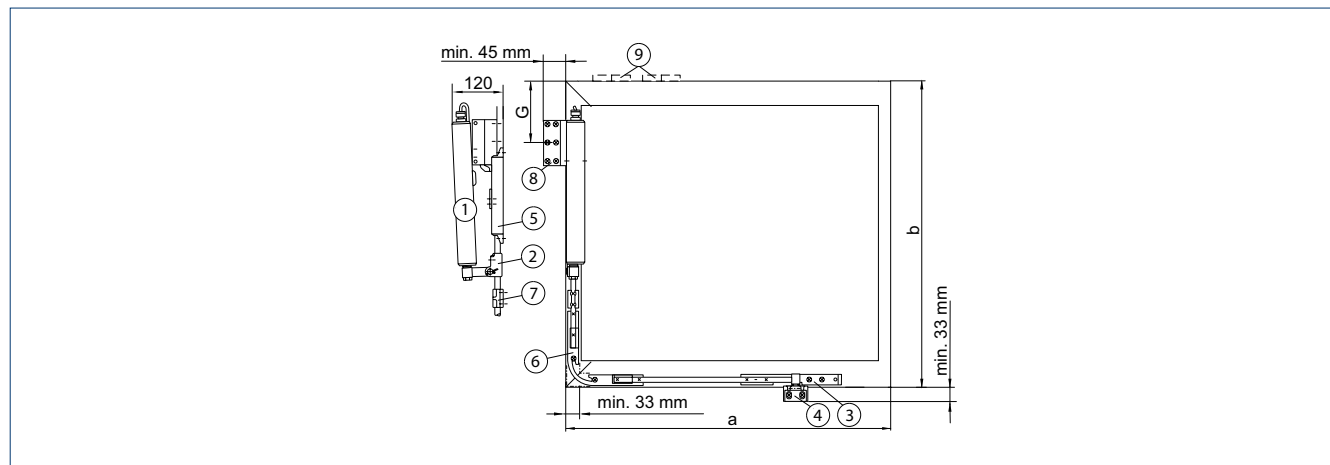

a = Clear frame width | b = Clear frame height | 1 = E 250 NT electric spindle drive | 2 = Rod transmission | 3 = Additional locking OL 320 | 4 = Additional bracket complete | 5 = Release spring | 6 = Corner transmission OL 320 | 7 = Rod guide OL 320 | 8 = Frame angle | 9 = 2 hinges on the drive side (to be provided by the customer)



## TYPES OF INSTALLATION

### PROFILES-MOUNTED SYSTEM FOR VERTICALLY INSTALLED, OUTWARD OPENING BOTTOM-, TOP- AND SIDE-HUNG WINDOWS

The given dimensions are standard; please contact GEZE if you require other dimensions.

Details for wooden/aluminium windows

#### RWA 110 NT

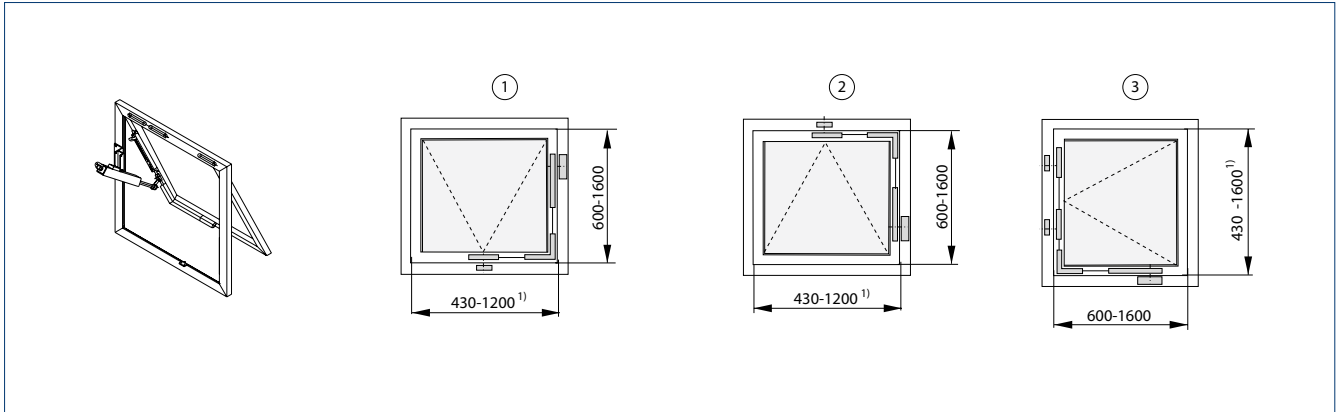

All dimensions in mm

1 = Top-hung window | 2 = Bottom-hung window | 3 = Side-hung window | 1 = For PVC windows Solo max. 800 mm

#### RWA 110 NT SYNCRO

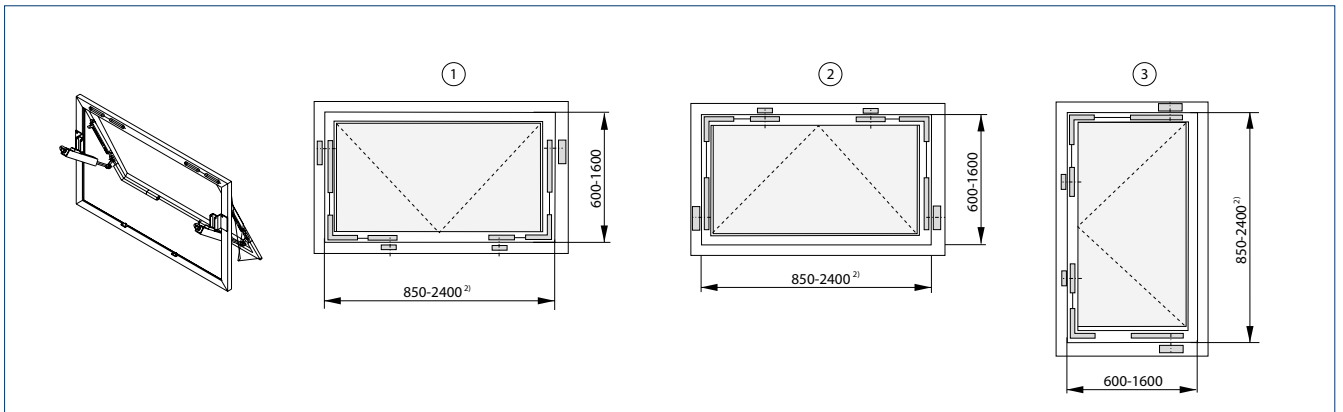

All dimensions in mm

1 = Top-hung window | 2 = Bottom-hung window | 3 = Side-hung window | 2 = For PVC windows Solo max. 1600 mm

## DETERMINATION OF THE MOTOR STROKE

### RWA 110 NT and RWA 110 NT Syncro: dimensions

											Stroke
Leaf dimension (b) [mm]	600-650	650-700	700-750	750-800	800-850						150
G dimension [mm]	70	80	100	125	150						
Opening angle [°]	approx. 46	approx. 44	approx. 42	approx. 39	approx. 37						
Opening width [mm]	approx. 510	approx. 530	approx. 540	approx. 540	approx. 540						
Leaf dimension (b) [mm]	650-700	700-750	750-800	800-850	850-900	900-950	950-1000				200
G dimension [mm]	115	130	155	175	200	225	250				
Opening angle [°]	approx. 53	approx. 51	approx. 48	approx. 46	approx. 43	approx. 41	approx. 39				
Opening width [mm]	approx. 640	approx. 650	approx. 650	approx. 670	approx. 670	approx. 670	approx. 670				
Leaf dimension (b) [mm]	900-920	920-950	950-1000	1000-1050	1050-1100	1100-1200	1200-1300	1300-1400	1400-1500	1500-1600	300
G dimension [mm]	260	280	310	330	360	420	500	580	630	700	
Opening angle [°]	approx. 56	approx. 54	approx. 51	approx. 49	approx. 47	approx. 43	approx. 39	approx. 35	approx. 33	approx. 31	
Opening width [mm]	approx. 880	approx. 870	approx. 870	approx. 880	approx. 880	approx. 860	approx. 860	approx. 830	approx. 840	approx. 840	

The values given for the opening angle and opening width are guideline values only and can vary depending on the type of installation and fitting dimensions G.

**ORDER INFORMATION**

Designation	Length	Stroke	Version	ID no.
RWA 110 NT		150 mm	EV1	153220
		150 mm	white RAL 9016	153221
		150 mm	according to RAL	153222
		200 mm	EV1	153223
		200 mm	white RAL 9016	153224
		200 mm	according to RAL	153225
		300 mm	EV1	153226
		300 mm	white RAL 9016	153227
		300 mm	according to RAL	153228
RWA 110 NT - special version				153229
Rod Ø 12 mm, without cover profile	2000 mm		galvanised	053198
	3000 mm		galvanised	053199
	6000 mm		galvanised	054116
Cover profile OL 320, length 2000 mm Mitre-cut at both ends			EV1	058771
			white RAL 9016	018293
			according to RAL	014258
Cover profile OL 320 length 3000 mm Mitre-cut at both ends			EV1	058774
			white RAL 9016	018294
			according to RAL	014259
Cover profile OL 320 length 6000 mm Straight-cut at both ends			EV1	058630
			white RAL 9016	018251
			according to RAL	013814
<b>ACCESSORIES</b>				
Additional bracket for overlap height 0 - 12 mm			EV1	050727
			white RAL 9016	015519
			according to RAL	013077
Corner transmission suitable for OL 320			galvanised	058648

# OL 360 EN



Opening and locking system for outward opening bottom-hung, top-hung and side-hung windows

## AREAS OF APPLICATION

- Natural ventilation (230 V) in the façade area
- Opening and locking of outward opening windows with tilt, top-hung and side-hung leaves
- Installation on wooden, PVC or metal windows
- Leaf installation

## PRODUCT FEATURES

- System solution with profile-mounted E 350 N spindle drive and a console set with locking device
- Mechanical locking at the main closing edge by the spindle drive
- Large opening widths with small spindle stroke
- Only Solo operation possible

## TECHNICAL DATA

### OL 360 EN

#### GENERAL INFORMATION

Space needed (min.)	leaf frame: min. 33 mm, cover frame: min. 45 mm
Permissible dimensions of main closing edge Solo for wooden and aluminium frames	430–1200 mm
Permissible dimensions of main closing edge Solo for PVC frames	430–800 mm
Clear frame height	600–1600 mm

#### SPECIFICATIONS

Possible stroke lengths	150 mm, 200 mm, 300 mm
Tensile force (max.)	750 N
Compressive force (max.)	750 N
Panel weight (max.)	30 kg/m <sup>2</sup> *

#### ELECTRICAL DATA

Operating voltage	230V AC
Current consumption	0.15 A
Power consumption (max.)	35 W
Cable dimensions	3 x 1.5 mm <sup>2</sup>
Temperature range	-20 – 70 °C
IP rating / protection rating	IP65 / II

#### FUNCTIONS

Locking device and additional bracket	●
End position cut-off extended	electromechanical
End position cut-off retracted	electromechanical
Overload cut-off	●

#### TYPES OF INSTALLATION

Bottom-hung window	outward opening	leaf
Side-hung window	outward opening	leaf
Top-hung window	outward opening	leaf

● = YES | \* = Higher leaf weights possible depending on application and type of installation. Exact calculation with Wincalc necessary.

## SYSTEM STRUCTURE

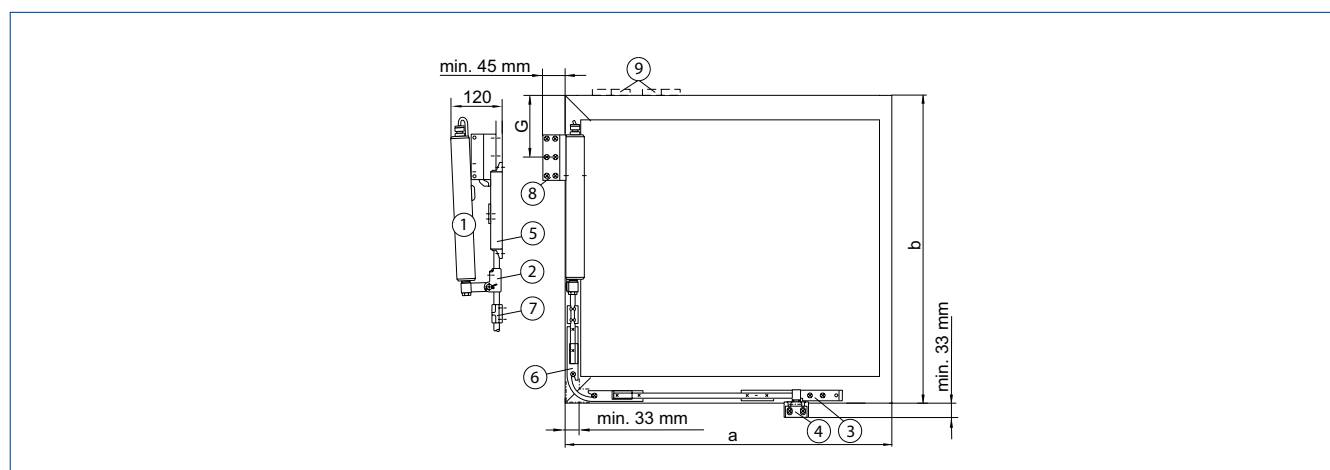

For details of fitting dimensions G and E, see table

a = Leaf width | b = Leaf height | 1 = Electric spindle drive E 350 | 2 = Rod transmission | 3 = Additional locking OL 320 | 4 = Additional bracket complete | 5 = Release spring | 6 = Corner transmission OL 320 | 7 = Rod guide OL 320 | 8 = Frame angle | 9 = 2 hinges on the drive side (to be provided by the customer)

## TYPES OF INSTALLATION

### PROFILE-MOUNTED SYSTEM FOR VERTICALLY INSTALLED, OUTWARD OPENING BOTTOM-, TOP- AND SIDE-HUNG WINDOWS

The given dimensions are standard; please contact GEZE if you require other dimensions.

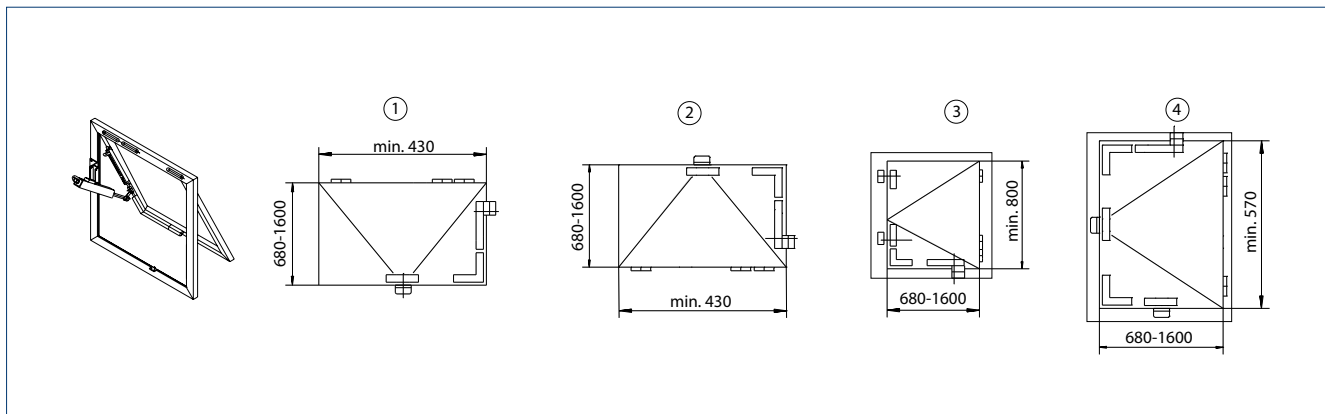

All dimensions in mm

1 = Top-hung window | 2 = Bottom-hung window | 3 = Side-hung window (if necessary with 2 locks) | 4 = Side-hung window

### FITTING DIMENSIONS G AND E DEPENDING ON MOTOR STROKE AND LEAF HEIGHTS

OL 360 EN Solo	Leaf height (b)	Dimension G	Opening angle	Opening width	Movement
Stroke 150 mm	680–700* mm	80 mm	approx. 44°	approx. 530 mm	65 mm
	700–750* mm	100 mm	approx. 42°	approx. 540 mm	75 mm
	750–800 mm	125 mm	approx. 39°	approx. 540 mm	100 mm
	800–850 mm	150 mm	approx. 37°	approx. 540 mm	132 mm
Stroke 200 mm	730–750* mm	130 mm	approx. 51°	approx. 650 mm	110 mm
	750–800* mm	155 mm	approx. 48°	approx. 650 mm	145 mm
	800–850 mm	175 mm	approx. 46°	approx. 670 mm	145 mm
	850–900 mm	200 mm	approx. 43°	approx. 670 mm	145 mm
	900–950 mm	225 mm	approx. 41°	approx. 670 mm	145 mm
	950–1000 mm	250 mm	approx. 39°	approx. 670 mm	145 mm
Stroke 300 mm	930–950* mm	280 mm	approx. 54°	approx. 870 mm	175 mm
	950–1000* mm	310 mm	approx. 51°	approx. 870 mm	175 mm
	1000–1050* mm	330 mm	approx. 49°	approx. 880 mm	145 mm
	1050–1100* mm	360 mm	approx. 47°	approx. 880 mm	145 mm
	1100–1200* mm	420 mm	approx. 43°	approx. 860 mm	145 mm
	1200–1300* mm	500 mm	approx. 39°	approx. 860 mm	145 mm
	1300–1400 mm	580 mm	approx. 35°	approx. 830 mm	145 mm
	1400–1500 mm	630 mm	approx. 33°	approx. 840 mm	145 mm
	1500–1600 mm	700 mm	approx. 31°	approx. 840 mm	145 mm

\* Shorten corner transmission by 50 mm

## ORDER INFORMATION

Designation	Stroke	Version	ID no.
OL 360 EN	150 mm	EV1	088055
	150 mm	white RAL 9016	088058
	200 mm	EV1	088060
	200 mm	white RAL 9016	088064
	300 mm	EV1	088067
	300 mm	white RAL 9016	088070

# RWA EM "OPEN"



## Electromagnetic smoke and heat extraction system for opening pure smoke and heat extraction windows

### AREAS OF APPLICATION

- Simple solution for smoke and heat extraction windows without ventilation function
- Inward and outward opening bottom-, top- and side-hung windows
- Leaf width up to 1200 mm with one locking device, 2400 mm with secondary lock locking device

### PRODUCT FEATURES

- Locking by magnetic locking in the fail-safe principle
- High level of safety through triggering in the event of malfunctions
- Windows must be closed manually after smoke and heat extraction alarm

## SYSTEM DESCRIPTION

The GEZE RWA EM "OPEN" system is a simple solution for opening windows used exclusively for smoke and heat extraction. With a leaf width of 300–1000 mm (top-hung leaf) or 1200 mm (bottom-hung leaf) locking is by means of a magnetic primary lock. With a leaf width of up to 2000 mm (top-hung leaf) or up to 2400 mm (bottom-hung leaf) locking is by means of a magnetic primary lock, a connecting link arm and a secondary lock. The magnetic primary lock and mechanical secondary lock keep the

window leaves securely closed against the pressure of the spring arms and the pressure of the wind. The magnet is continuously supplied with current and keeps the bolt in the closed position against a compression spring (fail-safe principle). As soon as the current is interrupted (e.g. if a fire is detected), the magnetic locking is released and the spring arms push the leaves open.

## SYSTEM STRUCTURE

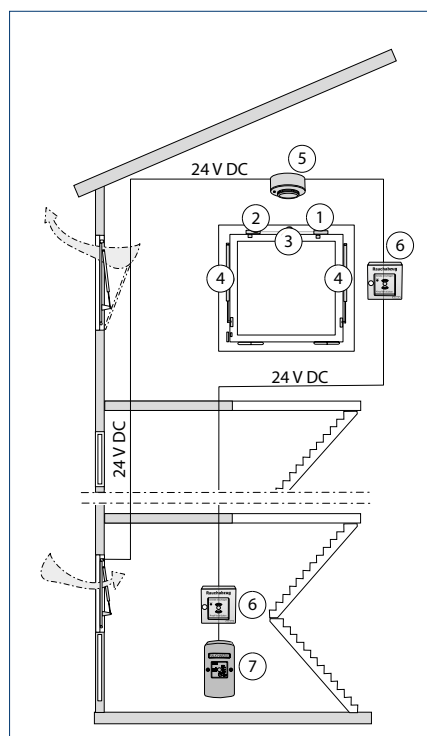

A = Mains connection

- 1 = Magnetic primary lock E8/a for 24 V DC with leaf bracket for wooden and metal windows
- 2 = Mechanical secondary lock C8/b with leaf bracket for overlap and flush-mounted windows, for wide leaves
- 3 = Connecting link arm for mechanical connection of primary to secondary lock
- 4 = Spring arm, with frame and leaf bracket, with back check spring pressure and spring stroke as well as spring force are matched to the window system
- 5 = One or several smoke and/or heat detectors (ceiling-mounted) for automatic activation
- 6 = SHEV button FT 4 for activation (number and layout depending on specifications from the building authorities)
- 7 = THZ, THZ Comfort or MBZ 300 emergency power control unit

## FUNCTIONAL DESCRIPTION

### OPENING OF THE WINDOWS BY INTERRUPTING THE STATIC CURRENT

- Manual: By pressing the FT 4 push button  
 Automatic: By activating the smoke and heat detectors and in the event of a line break

### MANUAL CLOSING OF THE WINDOWS

The static current flow must be re-established by resetting the push buttons or smoke and heat detectors. The windows can be closed by hand against the pressure of the spring arms and by pressing the magnet in the magnetic primary lock.

Using an emergency power supply prevents unwanted opening of the windows in the event of short power failures by automatically switching to battery mode in this case. This smoke and heat extraction system is not recommended for windows which can only be closed by climbing a ladder or scaffolding. It must be possible to manually close the system – this must also be taken into account for the six-monthly functional test.

## CHARACTERISTICS OF THE COMPONENTS

### Electromagnetic locking

- Pre-mounted construction units
- Housing and baseplate buffer made from aluminium leaf EV1
- Current consumption per primary unlocking 0.13 A
- In side-hung leaves: Leaf height min. 1.5 x leaf width

### Secondary lock

- Mechanical
- Can be coupled to primary lock via connecting link arm

### Spring arm

- Safe, space-saving and dirt-protected unit
- Pre-mounted unit (EV1)
- With back check
- Up to max. 30 kg/m<sup>2</sup> panel weight
- Stroke 150–300 mm
- Pressure force 150–250 N
- Opening angle up to 70° depending on stroke and leaf height

## ORDER INFORMATION

Designation	Stroke	Compressive force	ID no.
Magnetic lock E 8 A, 0.13A			010834
Secondary lock C 8 b			028092
Connecting link arm C 8/7, 6 x 1200			028125
Coupling sleeve C 8/12			052231
Spring arm	150 mm	150 N	057277
	200 mm	150 N	053049
	300 mm	150 N	057278
	400 mm	150 N	013436
	200 mm	250 N	053050
	300 mm	300 N	015934

# Components



Magnetic lock (010834)



Connecting sleeve (052231)



Spring arm (057277)





Photo: GEZE GmbH, Jürgen Polak





SWING DOOR / WINDOW

# Air intake

When a building catches fire, air intakes provide the necessary “air flow power”. This way fire smoke can escape. Here, the coordinated interaction of fresh air and exhaust air solutions is crucial. Openings in the lower part of the building are equipped with fresh air drives, allowing fresh air to enter. It amplifies the thermal chimney effect, so that flue gases can escape through the vents at the top of the building. GEZE offers complete smoke and heat extraction solutions.



# RWA TÖ



## Smoke and heat extraction fresh-air door with inversely mounted door closer

### AREAS OF APPLICATION

- Rarely used doors and side entrances
- Standard doors can be used for smoke and heat extraction fresh air
- Escape and rescue routes through combination with GEZE emergency exit systems

### PRODUCT FEATURES

- Cost-effective and easy to implement solution
- Limited access to the door during normal operation

## SYSTEM DESCRIPTION

The RWA TÖ system combines a door closer with a control panel and the corresponding accessories. This system provides the option of using a door as an SHEV fresh air opening and therefore of creating a large fresh air inlet area relatively quickly. Released by the emergency power control unit, the door is opened by the force of the inversely mounted door closer when smoke and heat extrac-

tion is needed. In rooms without windows or rooms in which – if a fire occurs – the windows are too small, or only have ventilation flaps, the door can serve as a smoke extraction opening in conjunction with the RWA TÖ system. This solution can also be used as an escape door in combination with the GEZE emergency exit system.

## SYSTEM STRUCTURE

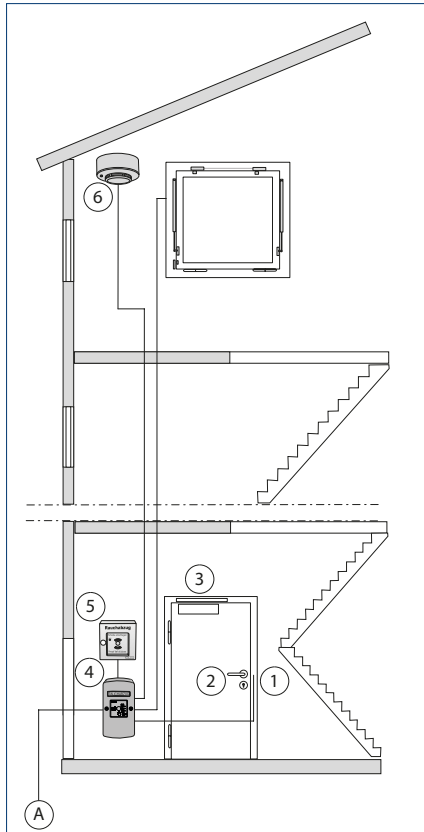

A = Mains connection

The following components are necessary for this system:

### In the lock area

- 1 = An electric strike model IQ eStrike A5000--E
- 2 = Door lock and door handle (are not directly part of the smoke and heat extraction system and must be supplied by the door manufacturer)

### On the door lintel

- 3 = A door closer TS 4000, TS 4000 EFS or TS 5000 in special installation

### In the area of the door or in an ancillary room

- 4 = A THZ, THZ Comfort, E 260 N 24 V DC, MBZ 300 emergency power control unit

### In the staircase

- 5 = SHEV button FT 4 for activation of the alarm (number and layout depending on specifications from the building authorities)
- 6 = One or more smoke detector(s) and/or heat detector(s) (ceiling installation) for automatic triggering IQ lock EL in the smoke and heat extraction case

## FUNCTIONAL DESCRIPTION

### Opening the door / alarm

In the event of an alarm, the emergency power control unit activates the electric strike. The inversely mounted door closer under spring tension opens the door. The door can be opened with the door handle without activating the smoke and heat extraction systems. The door opening angle is limited to approx. 90° (otherwise damage to closer is possible).

### Manual closing of the door / alarm reset

The alarm is reset via the reset button of the SHEV button FT 4 or, if triggered via a smoke and heat detector, by resetting the detector. The door must then be closed manually against the pressure of the inversely mounted door closer.

### Activation and supply via the emergency power control unit

The function is the same as with the standard smoke and heat extraction with electric drive, i.e. connection via the necessary motor group. Taking the overall current requirement into account, the IQ eStrike electric strikes are supplied with 24 V DC via the emergency power control unit and activated. In the event of an alarm (window OPEN), the IQ eStrike 5000--E electric strike is active (fail-secure principle). The alarm of the electric strike is triggered via the emergency power control unit.

### RWA TÖ "OPEN" on a 2-leaf door

The functional possibilities of the 2-leaf variant are the same as in the cases described above. The passive leaf must open later to ensure that both leaves of a 2-leaf door are not opened at the same time, causing them to get caught. This can be achieved by a timer relay or the GEZE activation delay block LEV, upstream of the electric strike.

**Combination with the GEZE emergency exit system (RWS)**

The functionality is similar to that of the standard version. An inverse door closer (with pre-tensioned spring) and an electric hold-open magnet (MA 500 with reed contact) are mounted on the door. The hold-open magnet is continuously supplied with current and keeps the door closed against the spring force of the door closer (fail-safe principle). The hold-open magnet is activated and supplied via an emergency exit system door control unit. In a panic case, the door control unit is released directly by pressing the emergency push button. The door control unit is connected to an SHEV emergency power control unit (relay alarm) via a potential-free N/C contact. In the event of a fire, an alarm is triggered and the magnet is released. The door is then opened by the spring force of the door closer. In this system, a key switch can also be used to unlock the central door control unit and pass the door. After the door has been passed it must be re-closed manually, against the spring force of the door closer.

→ **Note:** Further information about the emergency exit function and door control units can be found in the GEZE SecuLogic documentation.

**Combination with TS 4000 EFS**

(Inverse version/for comfortable access to the door during normal operation)  
The TS 4000 EFS free swing door closer (in special installation for the RWA TÖ “OPEN” system) in inverse activation enables the user to conveniently pass the door in routine operation.

**Functionality**

In the event of an alarm, the control panel deactivates the free swing function of the door closer and controls the electric strike. The tensioned spring of the door closer opens the door. After the alarm has been reset, the door must be closed manually to activate the free swing function.

→ **Note:** A combination with the GEZE IQ lock EL motor lock is possible. Please contact GEZE GmbH for details.

**ORDER INFORMATION**

Designation	Version	ID no.
TS 4000 door closer Closing force EN 5 - 7 with back check (without link arm)	silver-coloured	102837
Link arms TS 4000/2000 Standard	according to RAL	102425
TS 4000 EFS door closer Size EN 1 - 6, door leaf installation hinge side, with electric hold-open device for free swing function and connector box (without free swing link arm)	silver-coloured	105211
Link arms TS 4000 EFS/RFS with free swing function / free swing	silver-coloured	106460
TS 5000 door closer Closing force EN 2 - 6, with back check (without guide rail and lever)		160320
Guide rail TS 5000/TS 3000 Standard, with lever	silver-coloured	068221
<b>ACCESSORIES</b>		
GEZE door stop buffer for floor mounting	EV1	012921
GEZE THZ Compact staircase control unit with 3.4 A in one vent group and alarm group. Including battery.	white RAL 9016	139151
Diode 1N4007		115293
IQ eStrike A5000--E		145182

# Components



**GEZE THZ** (139151)



**Diode 1N4007** (115293)



**IQ eStrike A5000--E** (145182)

# RWA K 600 G



Retractable arm drive for installation on windows and doors  
with fixed connection by means of guide rail

## AREAS OF APPLICATION

- Smoke and heat extraction and natural ventilation (24 V)
- Inward and outward opening windows with bottom-, top- and side-hung leaves
- Installation on wooden, PVC or metal windows
- Leaf and frame installation
- Can be installed on the door

## PRODUCT FEATURES

- 90° window opening in less than 60 seconds
- Powerful drive with high torque
- Connection cable easily exchangeable by means of plug
- Integrated status contact for feedback signals
- Integrated Syncro module that can operate max. two drives without external control unit
- SHEV tested according to EN 12101-2



**TECHNICAL DATA**

<b>K 600 G</b>	
Dimensions	40 x 120 x 472 mm
Current consumption (max.)	1.4 A
Torque	215 Nm
Tensile force (max.)	600 N
Compressive force (max.)	600 N

**PRODUCT SCALE DRAWING**

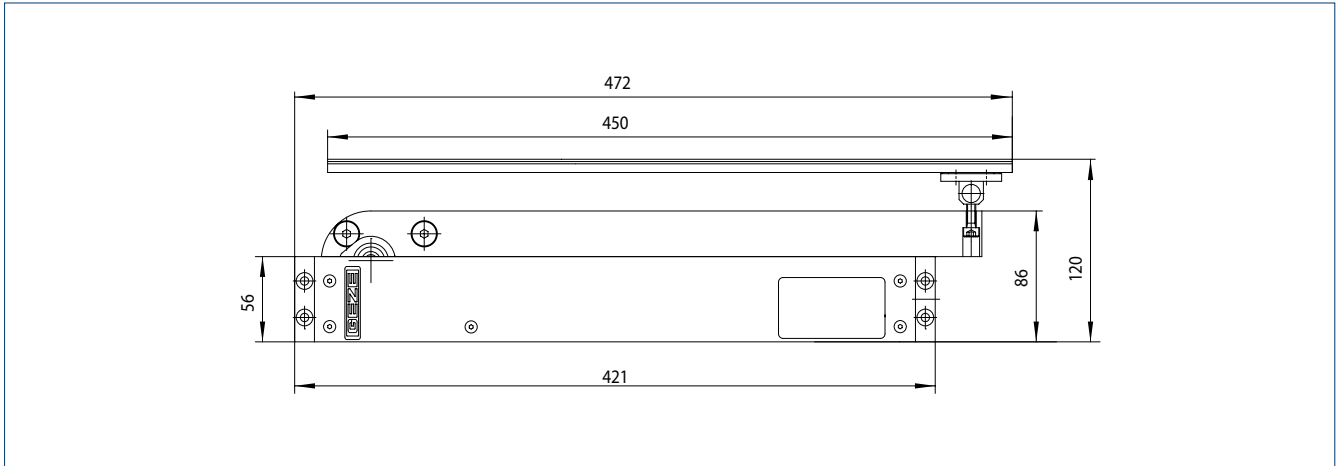

**TYPE OF INSTALLATION:**

	Window hinge side	Opposite hinge side	Door hinge side	Opposite hinge side
Leaf weight (max.)	on request <sup>3)</sup>		250 kg <sup>2)</sup>	
Leaf width (max.) <sup>1)</sup> main closing edge	800 mm Solo, 1200 mm Syncro		1600 mm <sup>2)</sup>	
Leaf width (min.) main closing edge	-		470 mm	565 mm
Leaf height (max.) <sup>2)</sup> secondary closing edge	2x + 880 mm		-	
Leaf height (min.) secondary closing edge	x + 465 mm		-	
Space needed (min.) on the frame	45 mm		45 mm	
Space needed (min.) on the leaf	-	45 mm	-	45 mm

- = No | 1 = A locking device is necessary for larger leaf widths | 2 = Higher values available on request | 3 = Depending on window type and opening angle

**HINGE-SIDE INSTALLATION ON THE DOOR – FITTING DIMENSIONS**

Plan view

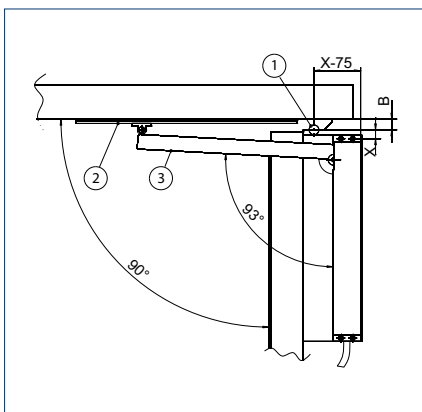

B = Hinge centre spacing | X = Distance of door hinge to drive attachment | 1 = Door hinge | 2 = Guide rail | 3 = Retractable arm

Head point detail

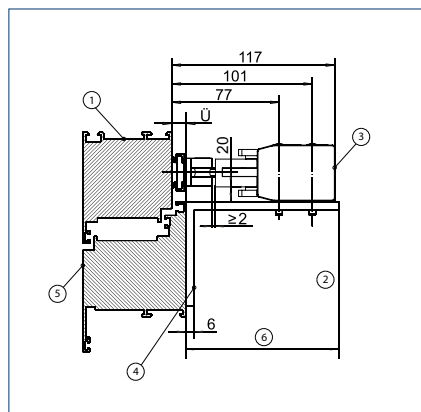

Ü = Overlap of the leaf beyond the frame (Ü ≤ 20 mm) | 1 = Door frame | 2 = On site | 3 = Drive | 4 = Mounting bracket console G | 5 = Door leaf | 6 = On site (depends on overlap)

Guide rail installation

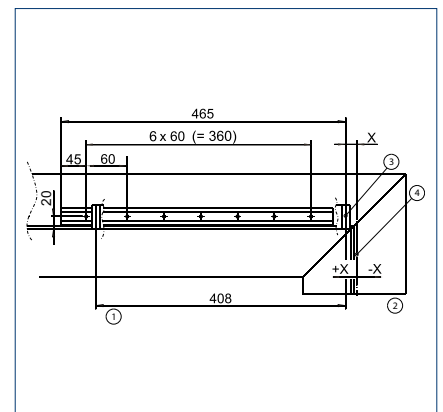

X = Distance between door hinge and drive attachment | 1 = Console for articulated lever | 2 = Door hinge | 3 = Drive attachment | 4 = Hinge axis

**DETERMINING THE X DIMENSION WITH  $\alpha = 90^\circ$ , EXAMPLES:**

Hinge size B	Distance between the door hinge and the drive attachment (X dimension) with $\alpha = 90^\circ$
13	30
22	20
36	5

Different opening angles / hinge centre spacings available on request

**OPPOSITE HINGE-SIDE INSTALLATION ON THE DOOR – FITTING DIMENSIONS**

Plan view

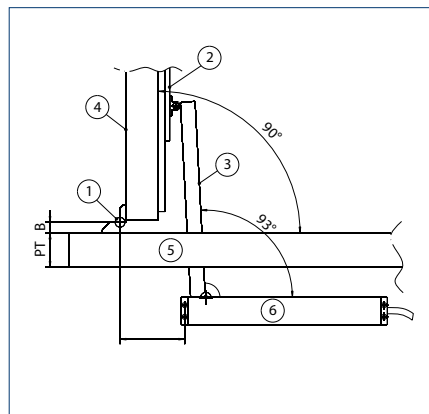

B = Hinge centre spacing | PT = Profile overall depth cover frame | 1 = Door hinge | 2 = Guide rail | 3 = Retractable arm | 4 = Door leaf | 5 = Door frame | 6 = Drive

Head point detail

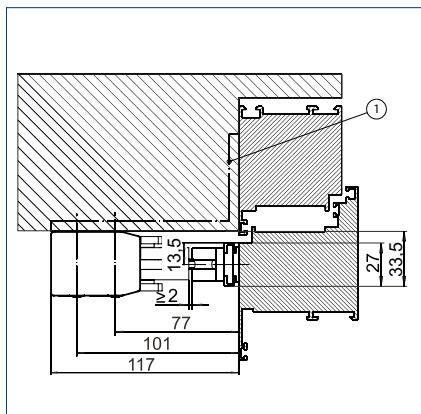

1 = Attachment drive in lintel already available on site or with console G

Guide rail installation

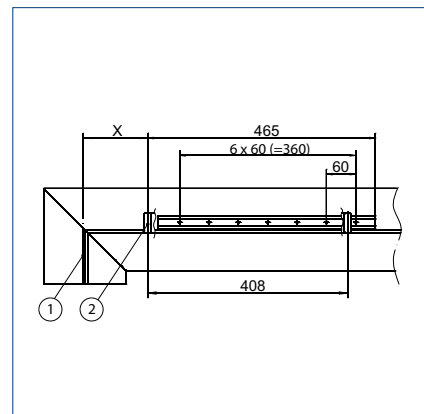

X = Distance between the door hinge to the drive attachment | 1 = Door hinge | 2 = Drive attachment

**DETERMINATION OF THE X DIMENSION AT  $\alpha = 90^\circ$  (DEPENDING ON B AND PT)**

Hinge centre spacing B	Profile overall depth cover frame PT	Distance between the door hinge and the drive attachment (X dimension) with $\alpha = 90^\circ$
22	40	100
22	50	110
22	60	120
22	65	125
22	70	130
22	75	135
22	80	140
36	40	115
36	50	125
36	60	135
36	65	140
36	70	145
36	75	150
36	80	155

Different opening angles / hinge centre spacings available on request

### HINGE-SIDE INSTALLATION ON WINDOW – FITTING DIMENSIONS

Plan view

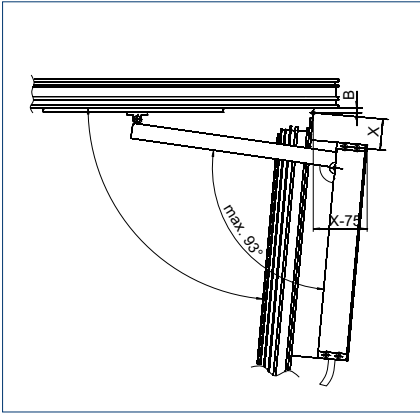

B = Hinge centre spacing | X = Distance between the window hinge and the drive attachment

Head point detail

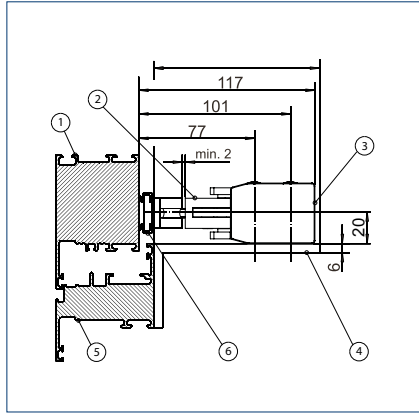

1 = Frame | 2 = Retractable arm | 3 = Drive | 4 = Mounting bracket console G | 5 = Leaf | 6 = Guide rail

Guide rail installation

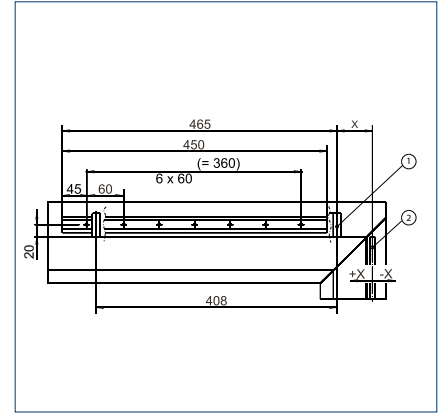

X = Distance of the window hinge to the drive attachment | 1 = Drive attachment | 2 = Door hinge

### WINDOW-OPENING ANGLE $\alpha = 90^\circ$ (DEPENDING ON B AND X)

Distance between the door hinge and the drive attachment X	Hinge centre spacing B	Opening angle $\alpha$
30	10	90°
60	10	85°
90	10	80°
120	10	75°
150	10	71°
190	10	65°
230	10	60°

Different opening angles / hinge centre spacings available on request.

### EXAMPLES OF RWA K 600 HINGE SIDE FOR INWARD OPENING BOTTOM-HUNG AND TOP-HUNG WINDOWS

Leaf dimensions		Panel weight		Number of drives
NSK	HSK	30 kg/m <sup>2</sup>	40 kg/m <sup>2</sup>	
800	800	x = 30 mm / $\alpha = 90^\circ$	x = 30 mm / $\alpha = 90^\circ$	Solo
800	1200	x = 30 mm / $\alpha = 90^\circ$	x = 30 mm / $\alpha = 90^\circ$	Syncro
1200	1200	x = 160 mm / $\alpha = 70^\circ$	x = 160 mm / $\alpha = 70^\circ$	Syncro

NSK = Secondary closing edge | HSK = Main closing edge

### OPPOSITE HINGE-SIDE INSTALLATION ON WINDOW – FITTING DIMENSIONS

Plan view

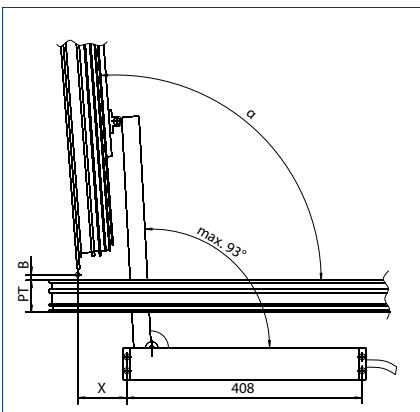

$\alpha$  = Opening angle | B = Door hinge | PT = Profile overall depth cover frame | X = Distance between the window hinge and the drive attachment

Head point detail

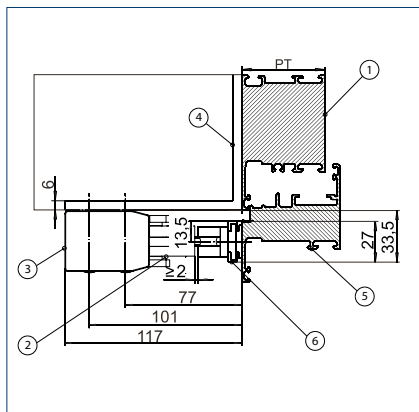

PT = Profile overall depth cover frame | 1 = Frame | 2 = Retractable arm | 3 = Drive | 4 = Mounting bracket console G | 5 = Leaf | 6 = Guide rail

Guide rail installation

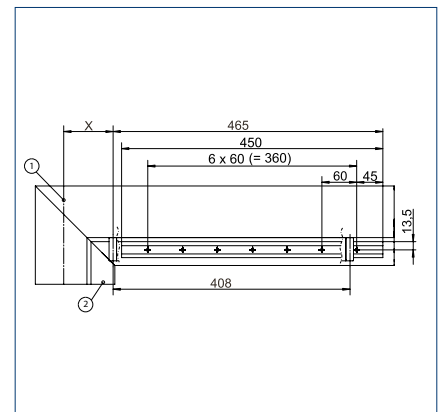

X = Distance of the window hinge to the drive attachment | 1 = Door hinge | 2 = Drive attachment

**WINDOW-OPENING ANGLE  $\alpha$  (DEPENDING ON X, B AND PT)**

Distance between the window hinge and the drive attachment X	Profile overall depth cover frame PT		Opening angle $\alpha$
Hinge centre spacing $B \leq 10$ mm	85	65	96°
	95	65	94°
	105	65	92°
	115	65	90°
	125	65	88°
	135	65	85°
	145	65	83°
	85	75	98°
	95	75	96°
	105	75	94°
	115	75	92°
	125	75	90°
	135	75	88°
	145	75	85°

**WINDOW-OPENING ANGLE  $\alpha$  (DEPENDING ON X, B AND PT)**

Distance between the window hinge and the drive attachment X	Profile overall depth cover frame PT		Opening angle $\alpha$
$10 \text{ mm} \leq$ hinge centre spacing $B \geq 22$ mm	85	65	99°
	95	65	97°
	105	65	95°
	115	65	93°
	125	65	90°
	135	65	88°
	145	65	86°
	85	75	101°
	95	75	99°
	105	75	97°
	115	75	95°
	125	75	93°
	135	75	90°
	145	75	88°

**EXAMPLES OF RWA K 600 G OPPOSITE HINGE SIDE FOR OUTWARD OPENING BOTTOM-HUNG AND TOP-HUNG WINDOWS**

Leaf dimensions		Panel weight		Number Drives
NSK	HSK	30 kg/m <sup>2</sup>	40 kg/m <sup>2</sup>	
800	800	x = 115 mm $\alpha = 90^\circ$	x = 115 mm $\alpha = 90^\circ$	Solo
800	1200	x = 115 mm $\alpha = 90^\circ$	x = 115 mm $\alpha = 90^\circ$	Syncro
1200	1200	x = 160 mm $\alpha = 80^\circ$	x = 160 mm $\alpha = 80^\circ$	Syncro

Profile overall depth (PT) cover frame = 65 mm | Hinge centre spacing (B) = 10 mm | NSK = Secondary closing edge | HSK = Main closing edge

**ORDER INFORMATION**

Designation	Version	ID no.
RWA K 600 G	EV1	130057
RWA K 600 G - SYNCRO	EV1	133119
RWA K 600 G 2-leaf with closing sequence	EV1	137447
RWA K 600 G double leaf with closing sequence - special version Can be configured: Passive/active leaf, start-up delay, cable length, status contact, colour		137448
RWA K 600 G - special version Can be configured: Version master/slave, status contact, cable length, colour, opening angle, free programming	according to RAL	130058

**ACCESSORIES**

Console G for RWA K 600	EV1	130155
	according to RAL	140507

# Console



**Console G for RWA K 600**  
(130155)

# RWA K 600 T



## Retractable arm drive for air intake for installation on doors

### AREAS OF APPLICATION

- Use in the supply air system where a large opening angle is required
- Single and double leaf smoke and heat extraction fresh air doors
- Installation on the hinge side or opposite hinge side

### PRODUCT FEATURES

- 90° door opening in less than 60 seconds
- Powerful drive with high torque
- Connection cable easily exchangeable by means of plug
- Integrated status contact for electric strike control unit or feedback signals
- Door remains freely accessible due to the freely positioned activation of the lever by means of a pressure roller

**TECHNICAL DATA**

<b>K 600 T</b>	
Dimensions	40 x 98,5 x 530 mm
Current consumption (max.)	1.4 A
Torque	215 Nm
Tensile force (max.)	600 N
Compressive force (max.)	600 N

**PRODUCT SCALE DRAWING**

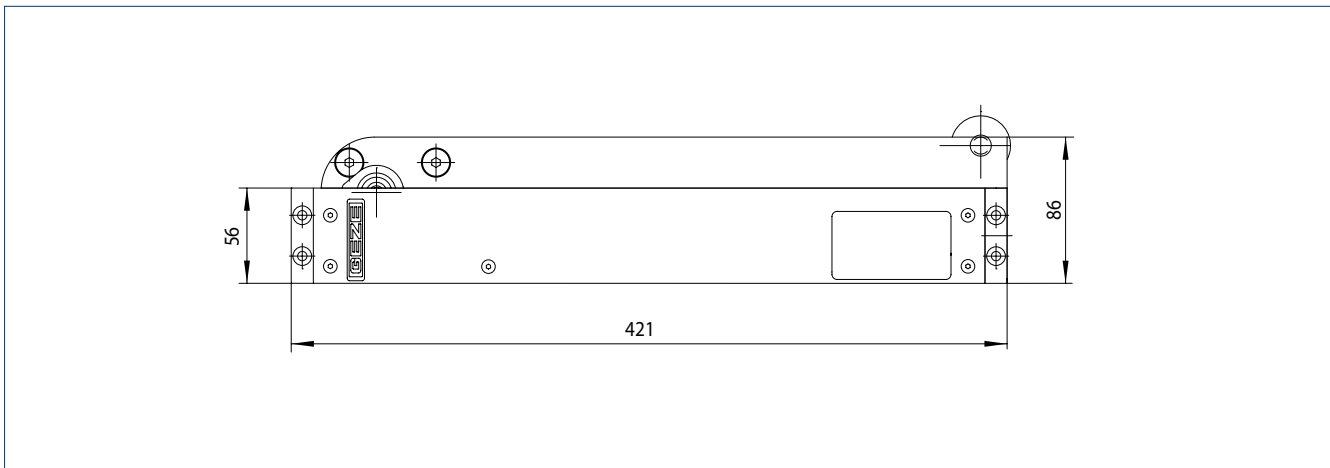

**TYPES OF INSTALLATION**

	<b>Window hinge side</b>	<b>Door hinge side</b>
Leaf weight (max.)	250 kg <sup>1)</sup>	250 kg <sup>1)</sup>
Leaf width (max.)	1600 mm <sup>1)</sup>	1600 mm <sup>1)</sup>
Leaf width (min.)	470 + x mm	470 + x mm
Consoles	Console R, console T	-
Space needed on the frame (min.)	at the side 45 mm	-
Space needed on the leaf (min.)	50 mm	40 mm

- = no | <sup>1)</sup> Higher values available on request

**HINGE-SIDE INSTALLATION ON THE DOOR – FITTING DIMENSIONS**

Plan view

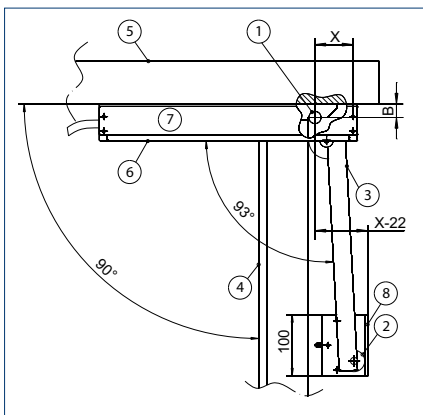

X = Distance of the door hinge to the drive attachment | 1 = Door hinge | 2 = Roller fitting | 3 = Retractable arm | 4 = Door leaf | 5 = Door frame | 6 = Drive | 7 = Console R | 8 = Console T

Head point detail

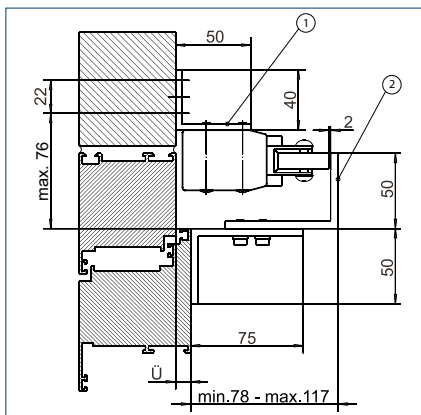

U = Overlap of the leaf beyond the frame | 1 = Console R | 2 = Console T

Installation consoles

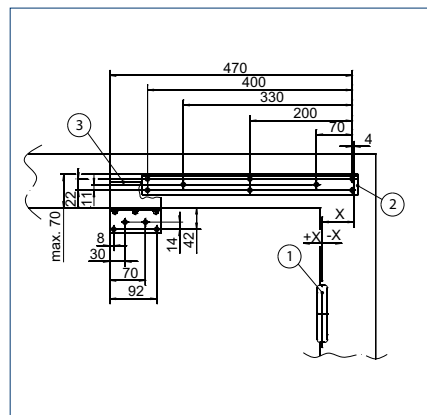

1 = Door hinge | 2 = Console R | 3 = Console T

### DETERMINING THE X DIMENSION WITH AN-OPENING ANGLE $\alpha = 90^\circ$

Hinge centre spacing B	Distance between the door hinge and the drive attachment (X dimension) with $\alpha = 90^\circ$	
	Overlap of the leaf beyond the frame $\ddot{U} = 0 \text{ mm}$	Overlap of the leaf beyond the frame $\ddot{U} = 10 \text{ mm}$
13	-60	-70
22	-55	-60
36	-45	-45

Different opening angles / hinge centre spacings available on request

### OPPOSITE HINGE-SIDE INSTALLATION ON THE DOOR – FITTING DIMENSIONS

Plan view

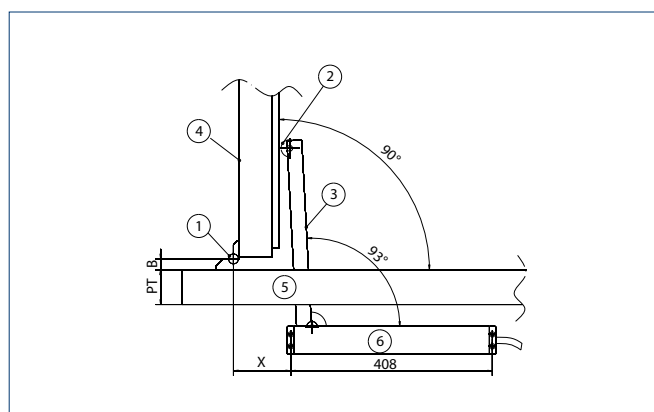

B = Hinge centre spacing | PT = Profile overall depth cover frame | 1 = Door hinge | 2 = Roller fitting | 3 = Retractable arm | 4 = Door leaf | 5 = Door frame | 6 = Drive

Head point detail

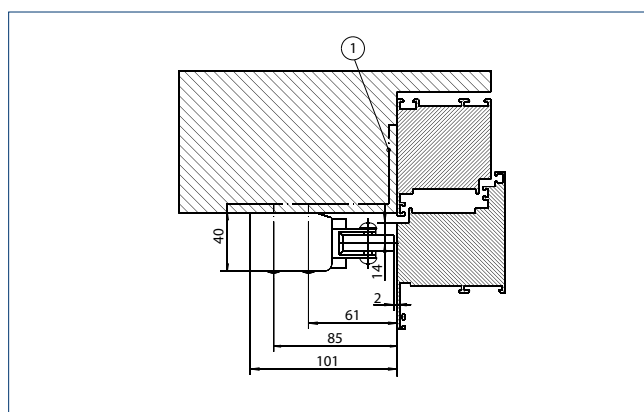

1 = Drive attachment in lintel already available on site or with console G

### DETERMINATION OF THE X DIMENSION AT $\alpha = 90^\circ$ (DEPENDING ON B AND PT)

Hinge centre spacing B	Profile overall depth cover frame PT	Distance between the door hinge and the drive attachment (X dimension) with $\alpha = 90^\circ$
22	40	80
22	50	90
22	60	100
22	65	105
22	70	110
22	75	115
22	80	120
36	40	95
36	50	105
36	60	115
36	65	120
36	70	125
36	75	130
36	80	135

Different opening angles / hinge centre spacings available on request.

→ **Note:** When a door closer is used, the minimum closing speed of the door closer must be limited to 5 seconds.



**ORDER INFORMATION**

Designation	Version	ID no.
RWA K 600 T	EV1	130059
RWA K 600 T - SYNCRO	EV1	133120
RWA K 600 T 2-leaf with closing sequence	EV1	137449
RWA K 600 T 2-leaf with closing sequence - special version Can be configured: passive/active leaf, start-up delay, cable length, status contact, colour		137450
RWA K 600 T - special version Can be configured: version master/slave, status contact, cable length, colour, opening angle, free programming	according to RAL	130060
<b>ACCESSORIES</b>		
Console T for RWA K 600	EV1 according to RAL	130153 140505

# Console



**Console T for RWA K 600**  
(130153)

Photo: GEZE GmbH, Jürgen Pollak



# RWA K 600 F



## Retractable arm drive for installation on windows

### AREAS OF APPLICATION

- Smoke and heat extraction and natural ventilation (24 V)
- Inward opening windows with bottom-, top- and side-hung leaves
- Installation on wooden, PVC or metal windows
- Frame installation

### PRODUCT FEATURES

- 90° window opening in less than 60 seconds
- Powerful drive with high torque
- Connection cable easily exchangeable by means of plug
- Integrated status contact for feedback signals
- Integrated Syncro module that can operate max. two drives without external control unit
- SHEV tested according to EN 12101-2

## TECHNICAL DATA

	<b>K 600 F</b>
Dimensions	40 x 86 x 421mm
Current consumption (max.)	1.4 A
Torque	215 Nm
Tensile force (max.)	600 N
Compressive force (max.)	600 N

## PRODUCT SCALE DRAWING

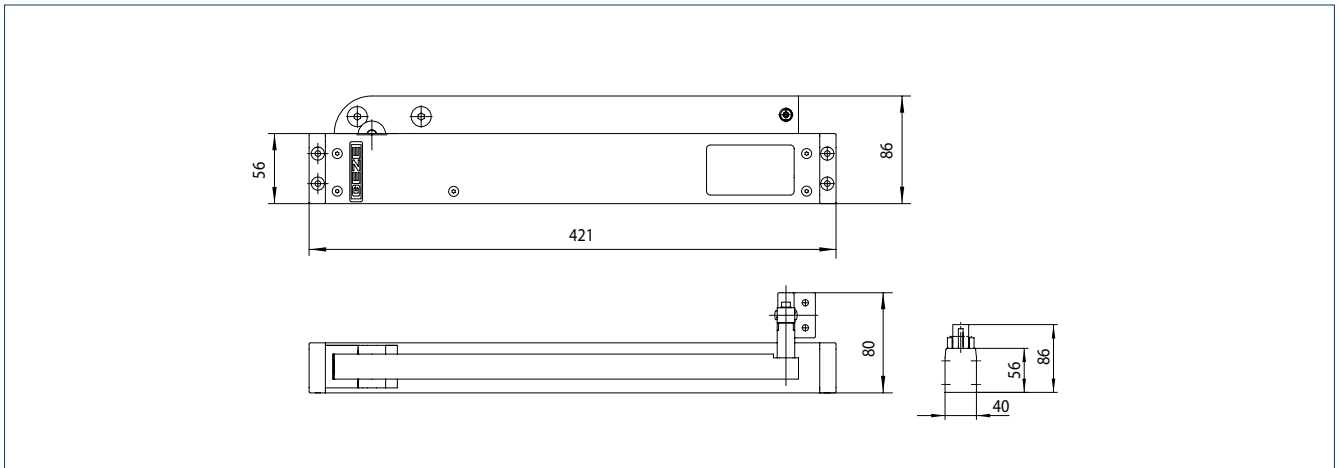

## TYPES OF INSTALLATION

	<b>Window hinge side</b>
Leaf weight (max.)	on request <sup>3)</sup>
Leaf width (max.) <sup>1)</sup> HSK	800 mm Solo, 1200 mm Syncro
Leaf width (min.) HSK	–
Leaf height (max.) <sup>2)</sup> NSK	2x + 750 mm
Leaf height (min.) NSK	x + 420 mm
Consoles	console R, console for articulated lever
Space needed (min.) on the frame	top 45 mm, side 55 mm
Space needed (min.) on the leaf	depends on the hinge centre spacing

– = no | <sup>1)</sup> A locking device is necessary for larger leaf widths. | <sup>2)</sup> Higher values available on request | <sup>3)</sup> Depending on window type and opening angle

### HINGE-SIDE INSTALLATION ON WINDOW – FITTING DIMENSIONS

Plan view

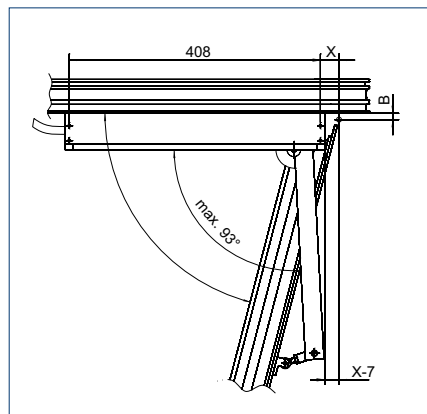

B = Hinge centre spacing | X = Distance between the window hinge and the drive attachment

Head point detail

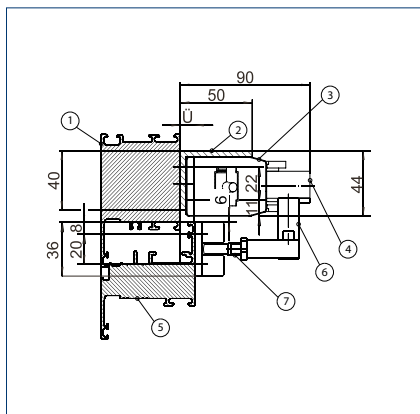

Ü = Overlap of the leaf beyond the frame |  
 1 = Frame | 2 = Console R | 3 = Drive |  
 4 = Retractable arm | 5 = Leaf | 6 = Articulated lever |  
 7 = Setting dependent on dimension of overlap

Installation of console R / for articulated lever

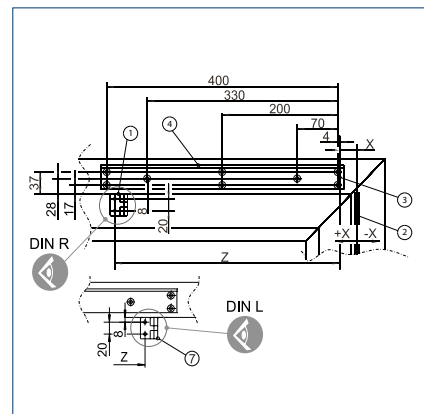

X = Distance of window hinge and the drive attachment | Z = Distance of the drive attachment to the console | 1 = Console for the drive lever | 2 = Window hinge | 3 = Drive attachment | 4 = Console R

### WINDOW-OPENING ANGLE $\alpha$ (DEPENDING ON B AND X)

	Distance between the window hinge and the drive attachment X	Opening angle $\alpha$	Z
Hinge centre spacing B = 10 ± 2	-35	84	410
	-30	83	410
	-20	82	410
	-15	81	390
	-10	81	390
	0	79	390
	10	77	370
	20	76	370
	30	75	370

Different opening angles / hinge centre spacings available on request

### EXAMPLES OF RWA K 600 F HINGE SIDE FOR INWARD OPENING BOTTOM-HUNG AND TOP-HUNG WINDOWS

Leaf dimensions		Panel weight		Number of drives
NSK	HSK	30 kg/m <sup>2</sup>	40 kg/m <sup>2</sup>	
800	800	x = -30 mm $\alpha$ = 83°	x = -30 mm $\alpha$ = 83°	Solo
800	1200	x = -25 mm $\alpha$ = 75°	x = -25 mm $\alpha$ = 75°	Syncro

Overlap (Ü) of the leaf beyond the frame = 10 mm | Hinge centre spacing (B) = 10 mm | NSK = Secondary closing edge | HSK = Main closing edge

**ORDER INFORMATION**

Designation	Version	ID no.
RWA K 600 F	EV1	130151
RWA K 600 F - SYNCRO	EV1	133221
RWA K 600 F 2-leaf with closing sequence	EV1	137451
RWA K 600 F 2-leaf with closing sequence - special version Can be configured: passive/active leaf, start-up delay, cable length, status contact, colour		137452
RWA K 600 F - special version Can be configured: version master/slave, status contact, cable length, colour, opening angle, free programming	according to RAL	130152
<b>ACCESSORIES</b>		
Console R for RWA K 600	according to RAL	140507
	EV1	130154
	according to RAL	140506

# Console



**Console R for RWA K 600**  
(130154)

# RWA AUT



Automatic opening of fresh air doors for smoke and heat extraction

## AREAS OF APPLICATION

- Large and heavy interior and exterior doors
- Use in escape and rescue routes

## PRODUCT FEATURES

- Fast and safe door opening when smoke and heat extraction is needed
- Passing the door during normal operation without restriction
- Combines comfort and safety

## SYSTEM DESCRIPTION

This system is used for automatically opening doors which, depending on their position in the building, can be used as supply air or exhaust air opening doors. In the event of an alarm. When smoke and heat extraction is needed, the door automatically opens in a very short time, triggered via the emergency power control unit. A large fresh air inlet surface is produced thanks to the large-opening widths of the GEZE automatic doors. Through combination with

automatic door systems, doors equipped with a smoke and heat extraction-opening (RWA AUT door) can also be passed extremely conveniently in everyday use. Protection of the automatic door in compliance with DIN 18650 / EN 16005 ensures convenience and safety. Combination with the GEZE emergency exit system permits use on emergency exits.

## SYSTEM STRUCTURE

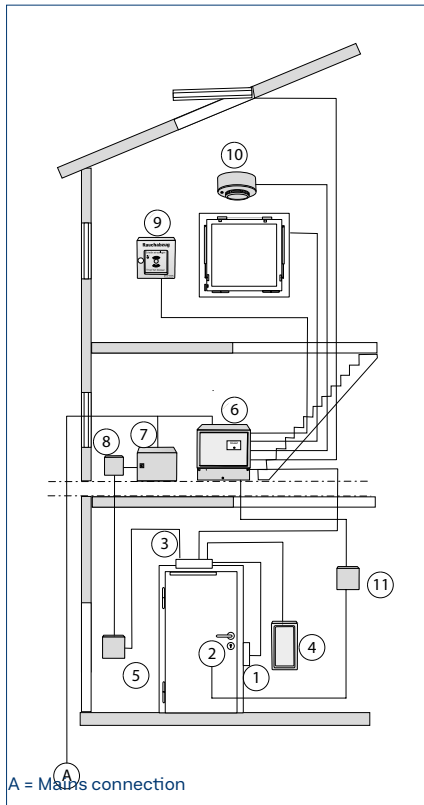

The system explained in the following is given as an example. Please contact GEZE for details of the options of other versions and variations.

### In the door

- 1 = FTV 320 escape door lock
- 2 = Strike plate for FTV 320

### On the door lintel

- 3 = TSA 160 NT Invers or EMD Invers swing door drive.

### Next to the door

- 4 = Elbow switch for opening the door in normal operation.  
Other types of activation e.g. radar are also possible.
- 5 = Emergency-off switch (door opens without current)

### In the building

- 6 = THZ, THZ Comfort, MBZ 300 emergency power control unit
- 7 = USV 700 or 1000 emergency power supply (necessary if the door must not open in the event of power failure)
- 8 = Main switch

### In the staircase

- 9 = SHEV button FT 4
- 10 = One or several smoke and/or heat detector(s) (ceiling-mounted) for automatic activation
- 11 = RWA MST 212 additional motor lock control for activation of the IQ Lock EL in the smoke and heat extraction case

## FUNCTION DESCRIPTION WITH FTV 320

Compared to TSA 160 NT swing door drive, which opens the door automatically and closes by spring force, the TSA 160 NT Invers drive inverts this function. In this case the closing action is automated, the opening takes place mechanically by means of spring force (advantage when smoke and heat extraction is needed). This means the GEZE Invers drives (Slimdrive EMD Invers and TSA 160 NT Invers) open in the event of a fire or power failure by means of spring force – fail-safe principle. Therefore, the use of fail-safe electric strikes (or hold-open magnets) is also necessary. Fail-secure electric strikes would not release the door in the event of a power failure. An uninterruptible power supply (UPS) is necessary to prevent unwanted-opening of the door in the event of a power failure (e.g. at night).

### Opening the door in case of emergency

In the event of an alarm from a fire button or smoke detector, the power supply to the drive and to the electric strike is interrupted. The doors are immediately unlocked and mechanically opened to ensure reliable smoke removal. The doors remain open until the alarm is reset.

### Opening the door in normal operation

The electric strike is unlocked by pressing an elbow switch or other pulse generator. The spring-tensioned swing door drive opens the door mechanically by means of spring force.

### Closing the door in normal operation

In normal operation the door automatically closes via the control unit of the swing door drive after the set hold-open time has expired.

### Supply to the shut-down indicator board

The shut-down indicator board of TSA 160 NT Invers must be supplied with an additional power supply. This is not necessary for Slimdrive EMD Invers.

### Manual passing the door

A door equipped with an Invers drive cannot be simply passed manually. With TSA 160 NT Invers, the door is locked not only by the escape door lock but also by the solenoid valve of the hydraulic system. With Slimdrive EMD Invers, the door is held in the closing position by a motor or by the escape door lock. Since manual passing the door does not generate an activation signal, the drive attempts to close the door again when it has been opened manually – this is comparable to the hold open position of the standard drive, from which it cannot be closed manually.

### Emergency power supply UPS

If the door must not be opened in the event of a power failure, the Invers, including the additionally required power supply unit, must be provided with a UPS.

**Note:** Version with automatic swing door drive in compliance with DIN 18650/EN 16005.

## FUNCTIONAL DESCRIPTION WITH THE IQ LOCK EL MOTOR LOCK

Slimdrive EMD Invers and TSA 160 NT Invers swing door systems can be combined with the IQ lock EL motor lock. Since the lock operates according to the fail-secure principle, when smoke and heat extraction is needed it is necessary to ensure that the lock is supplied with 24 V e.g. by an emergency power control unit. The IQ lock EL motor lock can only be used on single leaf doors. In addition, the printed circuit board MST 212 is necessary for the “smoke and heat extraction fresh air” function. If the control panel is activated in the case of fire, it forwards the signal to the lock and switches the Invers drive off at the same time.

### Opening the door in case of emergency

The additional board MST 212 is activated via a GEZE emergency power control unit. MST 212 supplies the motor lock with power and controls the lock, which unlocks the lock safely, i.e. even in the event of a power failure. The power supply to the Invers drive is interrupted via a contact on MST 212. As soon as the lock has been unlocked the door is opened by the spring force of the drive.

### Closing the door after an alarm:

After cancelling the alarm, activated SHEV buttons and/or the smoke and heat detectors must be reset. If the door is closed, it is automatically locked again via the motor lock or switches to the mode of operation set at the lock. The door is therefore locked again. After the alarm, the lock locks in precisely the same operating setting as the one set before the alarm (night/day/hold open). The TSA 160 NT Invers must be reset. With Slimdrive EMD Invers on the other hand, the drive changes to normal mode immediately after the alarm/fresh air status has been reversed.

### Opening the door in normal operation

IQ lock EL is unlocked by pressing an elbow switch or other pulse generator. The spring-tensioned swing door drive opens the door mechanically by means of spring force.

### Closing the door in normal operation

In normal operation the door automatically closes via the control unit of the swing door drive after the set hold-open time has expired. The shut-down indicator board is supplied via the power supply of MST 212.

### Manual passing the door

Manual opening of the door is possible by operating the inner door handle or with the aid of a key via a cylinder.



## FRESH AIR RWA AUT WITH EMD INVERS AND TSA 160 NT INVERS SWING DOOR DRIVE SYSTEMS AND EMERGENCY EXIT SYSTEM

---

### System arrangement

Additional components for emergency exit system control:

- TZ 320 door control unit
- KL 220 terminal box
- Additional N/C contact for emergency push button
- Uninterruptible power supply (UPS) optional

### Functional description

The shut-down indicator board of TSA 160 NT Invers is supplied with voltage from the door control unit and, in case of an emergency, is disconnected from the power supply so that the door reliably opens. At the same time the fire alarm system or alarm contact of the emergency power control unit is connected to the door control unit. A separate power supply for supplying the shut-down indicator board is not needed.

In order to prevent the door from opening unintentionally in the event of a power failure or to ensure that it is secured by the door control unit, TSA 160 NT Invers and the door control unit must be buffered via an uninterruptible power supply.

### Opening the door in case of emergency

If the emergency push button of the door control unit is pressed and in the event of an alarm of a fire button or smoke detector, TSA 160 NT Invers is disconnected from the power supply via the door control unit and at the same time the emergency exit electric strike is unlocked. The door is immediately opened mechanically and remains open until the alarm is reset.

### Closing the door after an alarm:

After an alarm has been cancelled, activated SHEV buttons and / or the smoke and heat detectors and any activated emergency buttons of the door control units must be reset. In addition, the alarm must be acknowledged at the door control unit by means of a key switch.

### Passing the door if emergency exit system is locked – secured operation

By activating the key switch of the door control unit or other release elements (card reader, external key switch), the door opens automatically, closes automatically after the short-term release (max. 5 minutes) and locks. The release elements of the Invers drives are not active here. If the short-term unlocking is exceeded, a pre-alarm is started, which switches to a door alarm after 3 minutes; this must be subsequently acknowledged at the door control unit using a key. For safety reasons, safety sensors are recommended for protection of the swivelling range.

### Passing the door if emergency exit system is unlocked – unsecured operation

By activating the release elements (elbow switch, radar detectors) of the Invers drives the door opens automatically by means of spring force and closes after the hold-open time set at the swing door drive has expired. For safety reasons, safety sensors are recommended for protection of the swivelling range.





## WINDOW

# Smoke and heat extraction control

Power supply units are the brain and the supply station of the smoke and heat extraction system in your building. They coordinate all smoke and heat extraction system components for safe smoke and heat extraction in case of fire. The emergency power supply units are the control unit for all fresh air and exhaust air openings equipped with smoke and heat extraction drives or door closers. They record the signals from the SHEV buttons and the automatic triggers, e.g. the smoke detectors, control the smoke and heat dissipation and monitor the components for faults.





# MBZ 300



Emergency power control unit for smoke and heat extraction drives  
with a total current consumption of 8 A to 72 A

## AREAS OF APPLICATION

- Small to large and networked smoke and heat extraction systems
- Control of electromotive 24 V DC drives for smoke and heat extraction in the event of a fire
- Control of a controlled natural ventilation

## PRODUCT FEATURES

- Modular design to allow flexible adaptation to project-specific requirements
- Convenient extension by clicking on other modules in a control unit
- Can be extended by alarm groups, ventilation groups and alarm lines as required
- Depiction of complex smoke and heat extraction scenarios
- Simple service and installation thanks to status display directly on the module
- Configuration software simplifies commissioning and configuration
- Wind direction dependent activation possible (SHEV according to EN 12101-2)
- Safety and reliability confirmed by VdS certification

### POSSIBLE CONNECTIONS FOR THE COMPONENTS

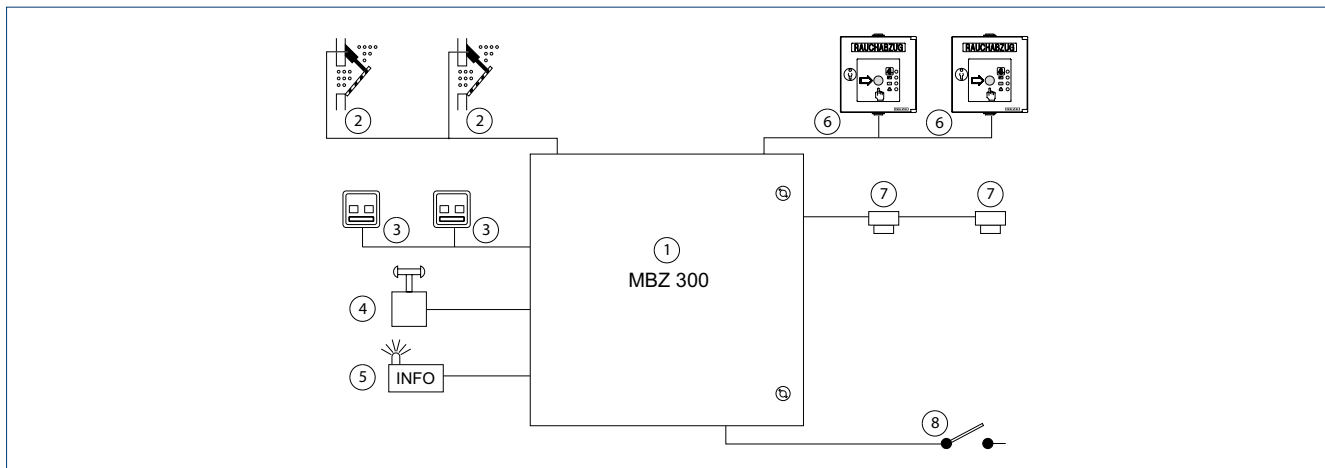

1 = MBZ 300 SHEV modular bus control unit | 2 = Drives of the window and smoke extraction flaps | 3 = Vent switch | 4 = Rain/wind control | 5 = Alarm interference signals | 6 = SHEV button | 7 = Smoke detector and heat detector | 8 = Alarm from external fire alarm system

### TECHNICAL DATA

#### GENERAL INFORMATION

	MBZ 300 N8	MBZ 300 N10	MBZ 300 N24	MBZ 300 N48 K/G	MBZ 300 N72	MBZ 300 configurable
Outer dimensions (mm)						
Height	400	400	600	600	600	depending on type
Width	300	500	600	600 / 800	800	
Depth	200	200	250	250	250	
Housing material	control cabinet made of painted sheet steel					
Colour	painted grey (RAL 7035)					
Type of installation	surface mounting					
Line-feed	from above, surface mounting					
IP rating	IP30, in compliance with EN 12101-10 environment class 1					
Ambient temperature	-5 to 40 °C, in compliance with EN 12101-10 environment class 1					

**ELECTRICAL**

		<b>MBZ 300 N8</b>	<b>MBZ 300 N10</b>	<b>MBZ 300 N24</b>	<b>MBZ 300 N48 K/G</b>	<b>MBZ 300 N72</b>	<b>MBZ 300 configurable</b>
Operating voltage (primary)	Mains supply voltage	230 V AC ±10 %, 50...60 Hz					
	Power	240 W	240 W	480 W	960 W	1440 W	depending on type
	Pre-fuse needed on site	16 A					
	Connection cross-section for feeder	3 x 1.5 mm <sup>2</sup> or 3 x 2.5 mm <sup>2</sup>					
Output voltage for drives	With mains supply	24 V DC ±5 %					
	With battery supply	24 V DC ±15 %					
	Residual ripple	2 %					
	Minimum output voltage	Minimum output voltages in compliance with EN 12101-10 Tab. 5: Drives 19.3 V / Report lines 18.2 V					
Output current for drives	In total	8 A	10 A	24 A	48 A (2x 24 A)	72 A (3x 24 A)	depending on type
	Duty rating	30 % ED					
	Per vent group	per DM 8 A per power supply 8 A	per DM 10 A per power supply 10 A	per DM 10 A per DME 20 A per power supply 24 A		depending on type	
Connection cross-section	Drives	min. 1.5 mm <sup>2</sup> / max. 2.5 mm <sup>2</sup>					
Emergency power supply	Nominal capacity of the battery	Standard battery: 7 Ah	Standard battery: 12 Ah	Standard battery: 17 Ah alternatively: 24 Ah, 38 Ah	Standard battery: 24 Ah alternatively: 38 Ah	Standard battery: 38 Ah	depending on type
	Battery voltage (charge voltage temperature-compensated)	2 x 12 V					
	Battery connection	Tab connector 4.8 mm	Tab connector 6.3 mm	Ring cable lug MS5	Ring cable lug MS5	Ring cable lug MS5	depending on type
	Duration	72 h (max.) standby operation with subsequent motor operation for 180 s (2x open / 1x close)					

**STRUCTURE**

Internal bus system for modular equipping

- The minimum equipment consists of 1 switching power supply, 1 PM power module, 1 CM control module and 1 DM drive module
- The maximum equipment can contain up to 21 bus modules (depending on the standard variant control cabinet) at a max. of 72 A (3 switching power supplies with 24 A each). If more power is needed, several units can be configured via the software as a combined unit.
- The following additional modules are possible: DM or DME drive module, SM sensor module, WM weather module, ERM relay module

**VARIANTS**

	<b>MBZ 300 N8</b>	<b>MBZ 300 N10</b>	<b>MBZ 300 N24</b>	<b>MBZ 300 N48 K/G</b>	<b>MBZ 300 N72</b>	<b>MBZ 300 configurable</b>
Built-in power supplies	1 switching power supply 10 A	1 switching power supply 10 A	1 switching power supply 24 A	2 switching power supplies 24 A	3 switching power supplies 24 A	depending on type
<b>Built-in modules:</b>						
PME	-	-	-	1	2	based on the basic control units sizes N10-N72, the number and order of the modules can be adapted for a specific project
PM	1	1	1	1	1	
CM	1	1	1	1	1	
DM	1	1	3	6	9	
Space for further modules	1	8	18	N48 K: 5 N48 G: 13	8	
Standard configuration	1 alarm group 1 vent group	1 alarm group 1 vent group	1 alarm group 3 vent groups	1 alarm group 6 vent groups	1 alarm group 9 vent groups	

**INPUTS/POSSIBLE CONNECTIONS**

		<b>MBZ 300 N8</b>	<b>MBZ 300 N10</b>	<b>MBZ 300 N24</b>	<b>MBZ 300 N48 K/G</b>	<b>MBZ 300 N72</b>	<b>MBZ 300 configurable</b>
Alarm activation per alarm group	Alarm line 1	per CM / SM: 10 SHEV buttons					
	Alarm line 2	per CM / SM: 10 smoke detectors / heat detectors or 1 x fire alarm system signal (external fire alarm system)					
	Alarm line 3	per CM / SM: 10 smoke detectors / heat detectors or 1 x fire alarm system signal (external fire alarm system)					
Ventilation control	Vent switch (example)	per DM / DME: 3 vent switches (LTA 24 AZ) with LED (or any number without LED connected)					
	Rain / wind	- weather station (potential-free contact) can be connected to CM control module without additional module - special rain/wind/wind direction sensor can be connected via additional WM weather module					
Other		- further alarm group or alarm lines with additional SM sensor module (not possible for N8) - further vent group with 10 A with additional DM drive module - further vent group with 20 A with additional DM drive moduleE (2 module slots) (not possible for N8) - 2 parameterisable signal inputs per DM					
Parameter setting		- simple configuration of alarm groups and vent groups using module sequence (without PC) - extended settings via MBZ 300 PC software (connection via USB mini)					

**OUTPUTS / SIGNALS**

		<b>MBZ 300 N8</b>	<b>MBZ 300 N10</b>	<b>MBZ 300 N24</b>	<b>MBZ 300 N48 K/G</b>	<b>MBZ 300 N72</b>	<b>MBZ 300 configurable</b>
Display	on the control unit	- visual operating and fault messages per module for fast localisation of faults - direct operating level on the modules					
Status contacts (outputs)		- potential-free message for alarm or interference on CM control module and SM sensor module - optional additional ERM relay module with 6 potential-free status contacts for alarm, interference or window statuses					
Networking of several control units		Optional linking of 30 control units via the MBZ 300 CAN bus (additional CAN module per control unit required)					

**OTHER FEATURES**

		<b>MBZ 300 N8</b>	<b>MBZ 300 N10</b>	<b>MBZ 300 N24</b>	<b>MBZ 300 N48 K/G</b>	<b>MBZ 300 N72</b>	<b>MBZ 300 configurable</b>
Modes of operation for drive supply		- standard drives - hold-open magnet mode of operation (continuous current draw approx. 30 % of the nominal current) - activation and supply of pressure gas generators					
Safety functions	Line monitoring	line monitoring for alarm and drive lines using line terminal resistors					
	Reaction at power failure	parameters can be set (window OPEN, CLOSE or no reaction)					
	Reaction with faults	parameters can be set (window OPEN, CLOSE or no reaction)					
	Vent switch	latching or dead-man operation (adjustable)					
Comfort functions	Automatic ventila- tion mechanism	adjustable running time, ventilation duration, automatic step control					
	Maintenance / service	adjustable maintenance timer, display of fault history, log function					
	Other	building-specific settings can be made to the control unit using the MBZ 300 software (see Possible configurations)					
Smoke and heat extraction functions	Travel direction alarm	parameters for the direction of travel of the drives can be set per alarm group					
	Smoke detector reset	reset button in the control unit and remote resetting of smoke detectors can be set via SHEV button					
	Fire alarm system function	fire alarm system signal can be adjusted in dead-man or self-locking function					
	Alarm re-initiation according to VdS 2581	deactivation possible					

**CERTIFICATES / TESTS**

<b>MBZ 300 N8</b>	<b>MBZ 300 N10</b>	<b>MBZ 300 N24</b>	<b>MBZ 300 N48 K/G</b>	<b>MBZ 300 N72</b>	<b>MBZ 300 configurable</b>
DIN EN 12101-10 E DIN EN 12101-9 VdS 2581 VdS 2593					

## MODULAR PRINCIPLE OF THE MBZ 300

Due to the possibility of software configuration and the extensive area of application of the modules, the control unit can be adapted to the individual smoke and heat extraction concept. The modules can be installed on a standard top hat rail (TS 35). After correct connection the module is recognised immediately by the internal bus and automatically integrated into the system. Further fire sections (SM) and ventilation groups (DM, DME) are formed automatically (self-teaching

function). Individual settings can be adapted for the ERM, WM and CAN modules using PC software. Faults and errors during connection are signalled through rapid flashing of the status displays or through the fault display. Fire sections and ventilation groups can be configured for each specific project thanks to the modular system.

## MBZ 300 MODULES

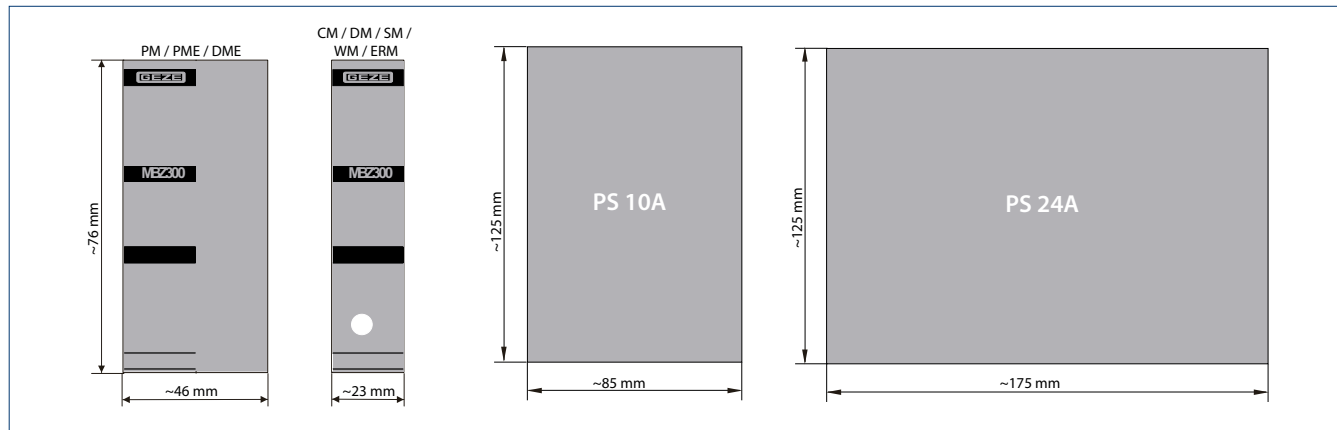

Size of the modules

### Power supply

Switching power supplies in 10 A or 24 A for power supply

#### PM

PM power module for connection of the first switching power supply and the rechargeable battery. This controls and monitors the mains and rechargeable battery voltage as well as the charging circuit and the automatic switchover of mains–battery operation.

#### PME

PME power module extension for controlling and monitoring every further switching power supply (max. 3 x 24 A switching power supplies for 72 A). It controls the automatic switchover of mains–battery operation.

#### CM

CM control module

- For the connection of 3 alarm lines (manual and automatic fire detectors as well as external EMERGENCY–OPEN activation signals)
- Input central button ventilation for all vent groups
- Status contact for interference or alarm
- USB connection for MBZ 300 configuration software

#### DM

DM drive module for max. 10 A drive current for connection of 24 V DC drives, push–buttons and control units. Pressure–gas generators or hold–open magnets can be triggered or supplied by corresponding programming.

#### DME

DME drive module extension for max. 20 A working current (needs 2 module slots). The DME has the same features as the DM. Terminal blocks are needed for the connection of the drives, so that cables with a larger cable cross section can also be connected.

#### SM

SM sensor module with the same possible connections as CM control module. The sensor module requires a control module to be present. An input for a central ventilation button for the fire section is available.

#### WM and sensors

WM weather module for operating wind and rain sensors and wind direction–dependent opening and closing of smoke exhaust units in the event of a fire. The special MBZ 300 weather sensors are used for this.

#### ERM

ERM relay module with 6 potential–free changeover contacts which can indicate faults, alarm messages or ventilation signals i.e. activation via a vent switch. The settings are made using the MBZ 300 software.

#### CAN

The CAN module is used for networking up to 30 MBZ 300. It is attached to the CM control module of every control unit to be networked.



**POWER SUPPLY PS 10 A (134333)**



**POWER SUPPLY PS 24 A (134334)**



**PM MODULE (134320)**



**PME MODULE (134331)**



**CM MODULE (134316)**



**DM MODULE (134317)**



**DME MODULE (145790)**



**SM MODULE (134318)**



**WM MODULE (134332)**



**ERM MODULE (149081)**



**CAN MODULE (134319)**



**Determining the correct design (hardware)**

- 1.) Determination of the number and power requirement of the drives including their distribution in groups
  - One DM drive module enables max. 10 A for the connection of drives.
  - One DME provides a max. of 20 A for the connection of drives.
  - At least one DM is required for each ventilation group.
  - Depending on the output current, a corresponding number of DM is assigned to one power supply.
  - The size of the control unit (MBZ 300 N10 to N72) is determined from the number of power supplies (max. 3).
- 2.) Number of alarm groups and their triggering elements (number of SHEV buttons, automatic detectors etc.)
  - The first alarm group is covered by the CM control module. SM sensor modules are required for further alarm groups.
- 3.) If e.g. weather sensors or other signal outputs are needed, further modules must be added (WM, ERM).
  - The housing size of the control unit selected is checked on the basis of the total number of modules.

The calculation program WinCalc in the GEZE partner portal provides support with the design.

## RECHARGEABLE BATTERIES FOR EMERGENCY POWER SUPPLY

Observe the following when selecting the rechargeable batteries:

- Back-up time for emergency power operation in case of power failure
- Max. drive current
- Number and types of the modules
- Number of connected detectors

The emergency power supply has to be ensured for 72 hours and motor operation still has to be possible subsequently for 180 seconds at the maximum motor current. This is taken into account in the following examples.

If permanent consumers (hold-open magnet mode of operation) are connected to the control unit, the rechargeable battery running time must be calculated separately.

### EXAMPLE FOR THE SELECTION OF THE NECESSARY BATTERY CAPACITY WITH MBZ 300 STANDARD CONTROL UNITS:

Battery capacity	N8	N10	N24	N48K	N48G	N72
7 Ah	Motor current: 8 A, 2 x DM, 20 x SHEV button, 20 x smoke detector					
12 Ah		Motor current: 10 A, 1 x SM, 5 x DM, 20 x SHEV button, 30 x smoke detector				
17 Ah			Motor current: 24 A, 1 x SM, 8 x DM, 30 x SHEV button, 30 x smoke detector			
24 Ah			Motor current: 24 A, 4 x SM, 1 2 x DM, 40 x SHEV button, 60 x smoke detector	Motor current: 48 A, 1 x SM, 9 x DM, 30 x SHEV button, 40 x smoke detector	Motor current: 48 A, – 1 x SM, 9 x DM, 30 x SHEV button, 40 x smoke detector	
38 Ah			Motor current: 24 A, 8 x SM, 24 x DM, 60 x SHEV button, 60 x smoke detector	Motor current: 48 A, 5 x SM, 22 x DM, 60 x SHEV button, 60 x smoke detector	Motor current: 48 A, 5 x SM, 22 x DM, 60 x SHEV button, 60 x smoke detector	Motor current: 72 A, 3 x SM, 18 x DM, 40 x SHEV button, 60 x smoke detector

– = no | The needed capacity has to be calculated in the case of deviating combinations.

### Module configuration

The module sequence results in the standard settings for alarm and vent groups (hardware configuration).

The configuration can be modified by instructed qualified personnel using an optional software. Configuration is simply by means of PC via the USB connection integrated in the CM control module. A licence is needed for the software.

### The most important possible configurations (via software):

- Assigning and combining ventilation groups
- Latching or dead-man operation of the vent switches
- Priority of the ventilation control units (by default the vent switch at the CM control module has a higher priority)
- Assigning, combining and prioritising alarm groups (fire sections) (by default the DM drive modules subordinated to the CM control module or SM sensor module form one fire section)
- Connection of pressure-gas generators or hold-open magnets instead of drives to the DM drive module
- Setting for wind direction dependent opening and closing in case of fire
- Wind speed threshold for automatic closing during ventilation
- Storing and logging the settings during commissioning and maintenance
- Requesting stored faults and events

## ORDER INFORMATION

Designation	Version	ID no.
MBZ 300 special version complete Modular SHEV emergency power control unit for the central control of individual smoke and heat extraction system components. Can be configured: Modules and their sequence, special software, rechargeable battery etc.		137453
MBZ 300 N8 Modular SHEV emergency power control unit for the central control of individual smoke and heat extraction system components with an output power of 8 A	grey	188034
MBZ 300 N8 Modular SHEV emergency power control unit for the central control of individual smoke and heat extraction system components with an output power of 8 A - with terminal blocks	grey	187322
MBZ 300 N10 Modular SHEV emergency power control unit for the central control of the individual components of a smoke and heat extraction system with an output power of 10 A	grey	137428
MBZ 300 N24 Modular SHEV emergency power control unit for the central control of the individual components of a smoke and heat extraction system with an output power of 24 A	grey	137430

Designation	Version	ID no.
MBZ 300 N48K Modular SHEV emergency power control unit for the central control of the individual components of a smoke and heat extraction system with an output power of 48 A	grey	137461
MBZ 300 N48G Modular SHEV emergency power control unit for the central control of the individual components of a smoke and heat extraction system with an output power of 48 A	grey	137462
MBZ 300 N72 Modular SHEV emergency power control unit for the central control of the individual components of a smoke and heat extraction system with an output power of 72 A	grey	137463
<b>ACCESSORIES</b>		
Rechargeable battery 7 Ah/12 V VdS suitable for MBZ 300 N10, E260 N12		028261
Rechargeable battery 12 Ah/12 V VdS suitable for MBZ 300 N10, E260 N12		020494
Rechargeable battery 17 Ah/12 V VdS suitable for MBZ 300 N24, E260 N32/2 - N32/8 VdS		111537
Rechargeable battery 24 Ah/12 V VdS suitable for MBZ 300 N24, MBZ 300 N48K, MBZ 300 N48G, E260 N32/2 - N32/8 VdS		020497
Power supply PS 10 A Switching power supply as a basis or extension of the output current of an MBZ 300 in connection with a PM or PME		134333
Power supply PS 24A Switching power supply as a basis or extension of the output current of an MBZ 300 in connection with a PM or PME		134334
CM module Central control module for the control panel. For 10 SHEV buttons, 10 smoke detectors, 1 fire alarm system input, central button for the first fire section and USB connection for the configuration software.		134316
DM module Vent group for connection of the smoke and heat extraction drives with 10 A switching capacity		134317
DME module Provides the same connection and adjustment options as a DM - but with a higher output power of 20 A - For connection of the drives an additional terminal block set (ID no. 150328) is necessary per module		145790
SM module For forming a further fire section: For 10 SHEV buttons, 10 smoke detectors, 1 fire alarm system input, central button for the fire section		134318
WM module For weather-dependent ventilation and wind direction-dependent activation when smoke and heat extraction is needed. In connection with weather sensors GC 401, GC 402, GC 403.		134332
ERM module 6 potential-free changeover contacts which can indicate faults, alarm signals or ventilation signals		149081
CAN module For connecting several MBZ 300 units		134319
Terminal block set 10 mm <sup>2</sup> For the connection of drive supply lines with larger cable diameter		150328
Terminal block set 4 mm <sup>2</sup> For the connection of drive supply lines with larger cable diameter		187323
PME module To extend the output current in conjunction with a further power pack		134331
PM module As basic unit with charge controller in conjunction with a power pack		134320
Replacement fuses MBZ 300		137245
Line end module (LEM) for SHEV motor lines		166090
Replacement resistors MBZ 300		136448
Rechargeable battery 38 Ah/12 V VdS		135694
Control cabinet lock MBZ 300		187355

# THZ



Emergency power control unit in compact housing  
for small smoke and heat extraction systems

## AREAS OF APPLICATION

- Smoke dissipation in staircases
- Possible connections for smaller smoke and heat extraction solutions
- For smoke and heat extraction drives with a total current consumption of 3.4 A
- Control of electromotive 24 V DC drives for smoke and heat extraction in the event of a fire
- Control of a controlled natural ventilation

## PRODUCT FEATURES

- Compact and attractive design with a plastic housing
- Safety and reliability confirmed by VdS and TÜV certification
- Highest flexibility due to extensive parameter setting options

## POSSIBLE CONNECTIONS FOR THE COMPONENTS

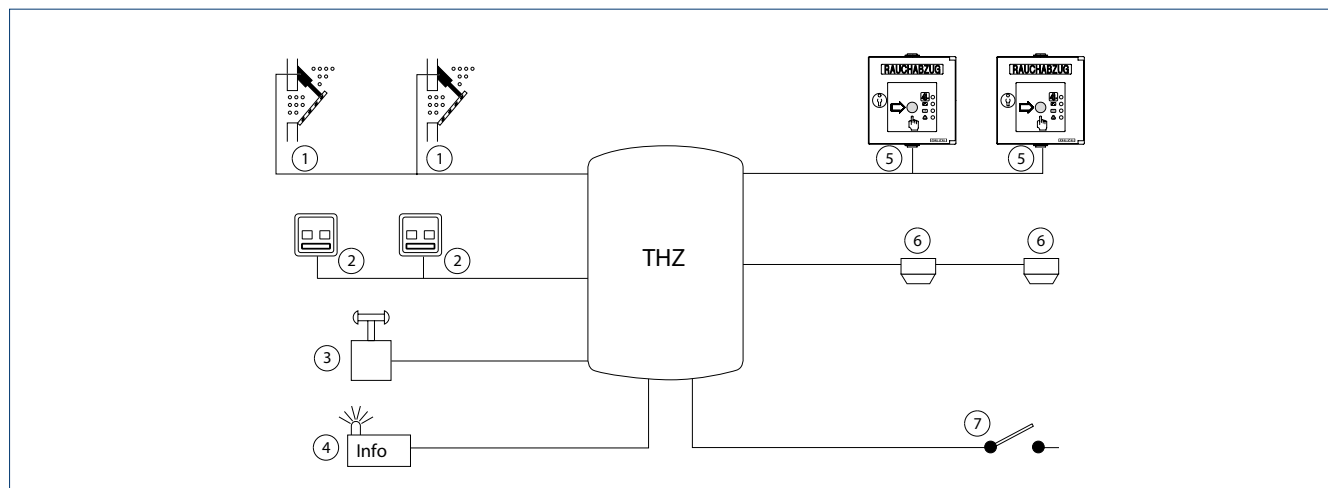

1 = Drives of the window and smoke extraction flaps | 2 = Vent switch | 3 = Rain/wind control | 4 = Alarm/interference signals | 5 = SHEV button | 6 = Smoke detector and heat detector | 7 = Alarm from external fire alarm system

## TECHNICAL DATA

### GENERAL INFORMATION

	THZ
Outer dimensions	193 x 285 x 89 mm
Housing material	plastic
Colour	white
Type of installation	surface mounting, installation in visible area possible
Line-feed	from above, surface or flush mounting possible
IP rating	IP 30
Ambient temperature	-5 – 40 °C

### ELECTRICAL

		THZ
Operating voltage (primary)	mains supply voltage performance pre-fuse needed on site connection cross-section for feeder	230 V AC ±10 %, 50...60 Hz 100 W 16 A 3 x 1.5 mm <sup>2</sup>
Output voltage for drives	with mains supply with battery supply residual ripple minimum output voltage	24 V DC ±5 % 24 V DC ±15 % 2 % –
Output current for drives	in total duty rating per vent group	3.4 A 20 % ED 3.4 A
Connection cross-section:	drives	min. 1.5 mm <sup>2</sup> / max. 2.5 mm <sup>2</sup>
Emergency power supply	nominal power of rechargeable battery battery voltage (charge voltage temperature-compensated) battery connection duration	2.1 – 2.3 Ah (lead rechargeable battery) 2 x 12 V tab connector 72 h (max.) standby operation with subsequent motor operation for 180 s (2x open / 1x close)

### STRUCTURE / VARIANTS (SCHEME FOR EACH CONTROL UNIT)

	THZ
Structure	Compact
Alarm groups	1
Vent groups	1

### INPUTS / POSSIBLE CONNECTIONS

		THZ
Alarm activation per alarm group	Alarm line 1	8 SHEV buttons
	Alarm line 2	10 smoke detectors / heat detectors or 1 x fire alarm system signal (external fire alarm system)
	Alarm line 3	10 smoke detectors / heat detectors or 1 x fire alarm system signal (external fire alarm system)
Ventilation control	Vent switch (example)	3 vent switches (LTA-24 AZ) with LED (or any number without LED connected)
	Rain/wind	Sensors (potential-free contact) can be connected without auxiliary module
Parameter setting		Service buttons and 5 LEDs

### OUTPUTS / SIGNALS

		THZ
Display	on the control unit	Illuminated LED display for operating, fault and maintenance signal
	on the control unit (visible from the outside)	–
Status contacts (outputs)		3 status contacts for which parameters can be set (e.g. interference, alarm, window OPEN)
Networking of several control units		Forwarding of alarm and reset signals for linking up to 10 control units

### OTHER FEATURES

		THZ
Modes of operation for drive supply		Standard drive or hold-open magnet mode of operation (0.8 A)
Safety functions	Line monitoring	Line monitoring for alarm and drive lines using line terminal resistors parameters can be set (window OPEN, CLOSE or no reaction) parameters can be set (window OPEN, CLOSE or no reaction) Self-locking or dead-man operation (adjustable)
	Reaction in the case of power failure	
	Reaction in the case of faults Vent switch	
Comfort functions	Automatic ventilation mechanism	adjustable running time, ventilation duration, automatic step control
	Maintenance / service	adjustable maintenance timer, display of fault history possible
	Other	–
Smoke and heat extraction functions	Direction of alarm travel Smoke detector reset	Parameters for the direction of travel of the drives can be set per alarm line Reset button in the control unit and remote resetting of smoke detectors via SHEV button can be set
	Fire alarm system function Alarm re-initiation according to VdS 2581	Fire alarm system signal can be adjusted in dead-man or self-locking function Deactivation possible

### CERTIFICATES / TESTS

THZ
Tested by the German Association for Technical Inspection DIN EN 12101-10 E DIN EN 12101-9 VdS 2581 VdS 2593

### ORDER INFORMATION

Designation	Version	ID no.
THZ - compact staircase control unit Compact staircase control unit with 3.4 A in one vent group and alarm group. Including rechargeable battery	white RAL 9016	139151

### ACCESSORIES

Terminal bag for THZ	140034
Replacement glass pane	151777
Accessories bag THZ	140029
Rechargeable battery 2.3 Ah Set of 2 x 12 V rechargeable batteries	028260

# THZ Comfort



Emergency power control unit in robust metal housing with illuminated SHEV and ventilation buttons for small smoke and heat extraction systems

## AREAS OF APPLICATION

- Smoke dissipation in staircases
- Possible connections for smaller smoke and heat extraction solutions
- Control of electromotive 24 V DC drives for smoke and heat extraction in the event of a fire
- Control of a controlled natural ventilation

## PRODUCT FEATURES

- Compact and attractive design with a very robust metal housing
- Integrated illuminated SHEV and ventilation button for more safety
- Adjustable backlight of the SHEV button
- Safety and reliability confirmed by VdS and TÜV certification
- Highest flexibility due to extensive setting parameters options
- Quick and easy commissioning with the GEZE ST 220 service terminal
- Reduced installation effort thanks to integrated push buttons

**POSSIBLE CONNECTIONS FOR THE COMPONENTS**

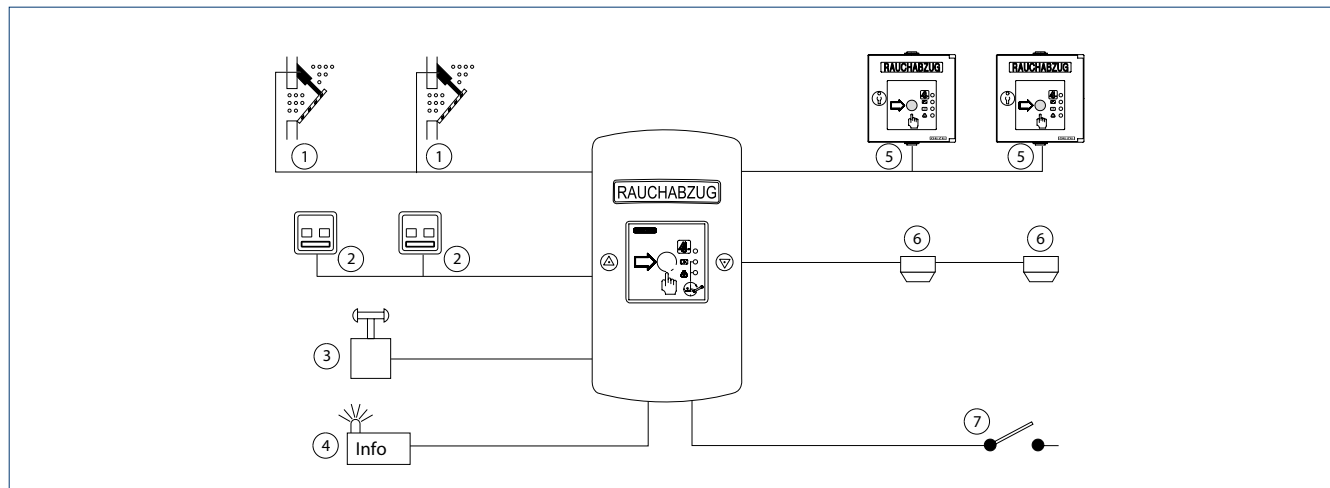

1 = Drives of the window and smoke extraction flaps | 2 = Vent switch | 3 = Rain/wind control | 4 = Alarm/interference signals | 5 = SHEV button | 6 = Smoke detector and heat detector | 7 = Alarm from external fire alarm system

**TECHNICAL DATA**

**GENERAL INFORMATION**

	<b>THZ Comfort</b>
Outer dimensions	140 x 248 x 85 mm
Housing material	aluminium die casting
Colour	lower part: grey, RAL 7035 cover: orange, RAL 2011 or according to version (VdS approval only for the colour orange)
Type of installation	surface mounting, installation in visible area possible
Line-feed	from above, surface or flush mounting possible
IP rating	IP 30
Ambient temperature	-5–40 °C

**ELECTRICAL**

		<b>THZ Comfort</b>
Operating voltage (primary)	mains supply voltage performance pre-fuse needed on site connection cross-section for feeder	230 V AC ±10 %, 50...60 Hz 100 W 16 A 3 x 1.5 mm <sup>2</sup>
Output voltage for drives	with mains supply with battery supply residual ripple minimum output voltage	24 V DC ±5 % 24 V DC ±15 % 2 % minimum output voltages in compliance with EN 12101-10 Tab. 5: drives 20 V / detector lines 19.5 V
Output current for drives	in total duty rating per vent group	3.4 A 30 % ED 3.4 A
Connection cross-section:	drives	min. 1.5 mm <sup>2</sup> / max. 2.5 mm <sup>2</sup>
Emergency power supply	nominal power of rechargeable battery battery voltage (charge voltage temperature-compensated) battery connection duration	2.1 – 2.3 Ah (lead rechargeable battery) 2 x 12 V tab connector 72 h (max.) standby operation with subsequent motor operation for 180 s (2x open / 1x close)

**STRUCTURE / VARIANTS (SCHEME FOR EACH CONTROL UNIT)**

	<b>THZ Comfort</b>
Structure	Compact
Alarm groups	1
Vent groups	1



**INPUTS / POSSIBLE CONNECTIONS**

		THZ Comfort
Alarm activation per alarm group	Alarm line 1	1 SHEV button already integrated + 8 further SHEV buttons can be connected
	Alarm line 2	10 smoke detectors / heat detectors or 1 x fire alarm system signal (external fire alarm system)
	Alarm line 3	10 smoke detectors / heat detectors or 1 x fire alarm system signal (external fire alarm system)
Ventilation control	Vent switch (example)	1 vent switch already integrated + 3 vent switches (LTA-24 AZ) with LED (or any number without LED connected)
	Rain/wind	Sensors (potential-free contact) can be connected without auxiliary module
Parameter setting		Service buttons and 5 LEDs or ST220

**OUTPUTS / SIGNALS**

		THZ Comfort
Display	on the control unit	Illuminated LED display for operating, fault and maintenance signal
	on the control unit (visible from the outside)	through the integrated SHEV and vent switch: Displays for alarm, operation, interference and maintenance as well as window OPEN / CLOSE
Status contacts (outputs)		3 status contacts for which parameters can be set (e.g. interference, alarm, window OPEN)
Networking of several control units		Forwarding of alarm and reset signals for linking up to 10 control units

**OTHER FEATURES**

		THZ Comfort
Modes of operation for drive supply		Standard drive or hold-open magnet mode of operation (0.8 A)
Safety functions	Line monitoring	Line monitoring for alarm and drive lines using line terminal resistors parameters can be set (window OPEN, CLOSE or no reaction) parameters can be set (window OPEN, CLOSE or no reaction) Self-locking or dead-man operation (adjustable)
	Reaction in the case of power failure Reaction in the case of faults Vent switch	
Comfort functions	Automatic ventilation mechanism Maintenance / service Other	adjustable running time, ventilation duration, automatic step control adjustable maintenance timer, display of fault history possible <b>unique!</b> Background lighting of the SHEV button (adjustable)
Smoke and heat extraction functions	Direction of alarm travel Smoke detector reset	Parameters for the direction of travel of the drives can be set per alarm line Reset button in the control unit and remote resetting of smoke detectors via SHEV button can be set Fire alarm system signal can be adjusted in dead-man or self-locking function Deactivation possible
	Fire alarm system function Alarm re-initiation according to VdS 2581	

**CERTIFICATES/TESTS**
**THZ Comfort**

Tested by the German Association for Technical Inspection  
 DIN EN 12101-10  
 E DIN EN 12101-9  
 VdS 2581  
 VdS 2593

**ORDER INFORMATION**

Designation	Version	ID no.
THZ Comfort – compact staircase control unit	white RAL 9016	140905
Compact staircase control unit with 3.4 A in one vent group and alarm group, and integrated SHEV and vent switch. Including battery	blue RAL 5015	140902
	grey RAL 7035	140904
	orange RAL 2011	140900
	yellow RAL 1021	140903
	red RAL 3001	140901
	according to RAL	140906

**ACCESSORIES**

Spare key for THZ Comfort	142113
Terminal bag for THZ	140034
Replacement glass pane	151777
Accessories bag THZ	140029
Rechargeable battery 2.3 Ah Set of 2 x 12V rechargeable batteries	028260

# E 260 N8/2



## Emergency power control unit for medium-sized smoke and heat extraction systems

### AREAS OF APPLICATION

- For smoke and heat extraction and smoke dissipation in stairwells
- Control of electromotive 24 V DC drives for smoke and heat extraction in the event of a fire
- Control of a controlled natural ventilation

### PRODUCT FEATURES

- LED indicator lights for operating and control indication
- Tried and tested supply and control of smoke and heat extraction systems for compliance with the fire safety regulations
- Takes over the power supply and control of the smoke and heat extraction drives in the event of fire and in ventilation mode
- 72 hours emergency power supply
- Settings are possible via jumper or service keys

**POSSIBLE CONNECTIONS FOR THE COMPONENTS**

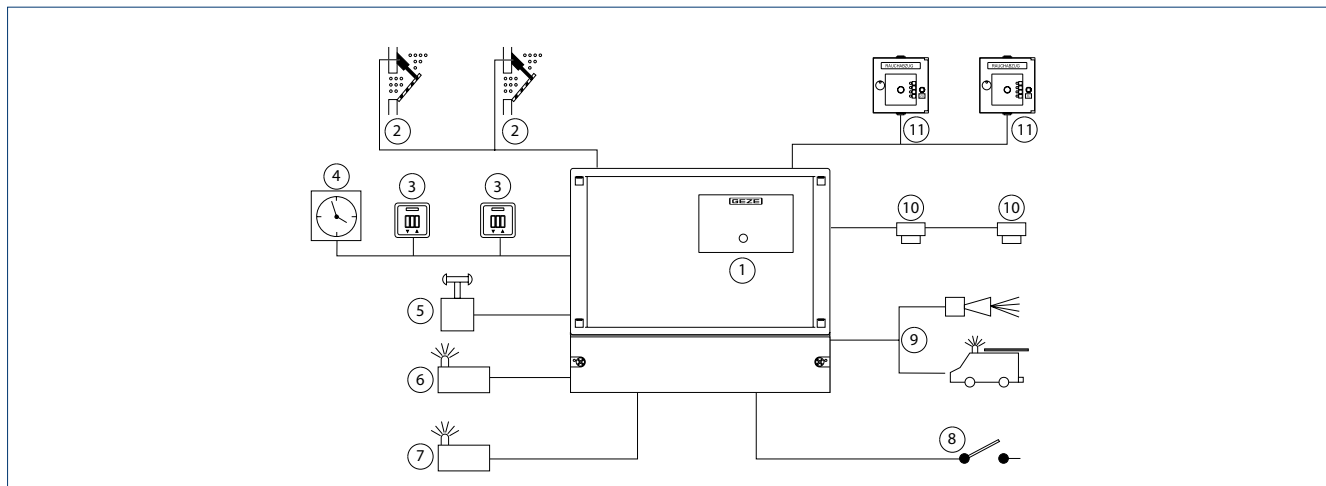

1 = SHEV emergency power supply unit | 2 = Drives for windows and smoke extraction flaps | 3 = Vent switch | 4 = Timer | 5 = Rain/wind control | 6 = Signal window OPEN (optional) | 7 = Signal fault (optional) | 8 = Alarm from external fire alarm system | 9 = Signal alarm (alarm forwarding) (optional) | 10 = Smoke detector and heat detector | 11 = RWA buttons

**TECHNICAL DATA**

**E 260 N8/2**

**GENERAL INFORMATION**

Dimensions	362 x 319 x 131 mm
Housing material	plastic
Colour	grey
Type of installation	surface mounting
Line-feed	from below, surface mounting
IP rating	IP54
Ambient temperature	-5 - 40 °C, environmental class III

**ELECTRICAL DATA**

Operating voltage (primary)	Mains supply voltage	230 V AC ±10 %, 50 Hz
	Performance	260 VA
	pre-fuse needed on site	16 A
	Connection cross-section for feeder	3 x 1.5 mm <sup>2</sup> or 3 x 2.5 mm <sup>2</sup>
Output voltage for drives	with mains supply	24 V DC (20-30 V)
	with battery supply	24 V DC (20-30 V)
	Residual ripple	20 %
Output current for drives	in total	7.5 A
	Duty rating	with mains operation: 25 %, max. duty rating: 5 min
	per vent group	7.5 A (7.5 A in total)
Connection cross-section:	Drives	maximum 4.0 mm <sup>2</sup>
Emergency power supply	Nominal capacity of the rechargeable battery	6 - 7.2 A (lead rechargeable battery)
	Battery voltage	2 x 12 V
	(charge voltage temperature-compensated)	
	Battery connection	Tab connector
	Duration	72 h (max.) standby operation with subsequent motor operation for 180 s (2x open / 1x close)

**SPECIFICATIONS**

Structure	Compact
Alarm groups	1
Vent groups	2 vent groups

**CONFIGURATION**

Alarm activation per alarm group	Alarm line 1 Alarm line 2 Alarm line 3	10 SHEV buttons 10 smoke detectors / heat detectors 1x fire alarm system signal (external fire alarm system)
Ventilation control	Vent switch (example)  Rain/wind	per group: vent switch LTA-24 (3 pcs) vent switch LTA-230 (any number) sensors (potential-free contact) can be connected without auxiliary module
Parameter setting		jumper
Display	on the control unit on the control unit (visible from the outside)	status display via LED display illuminated display on the front of the housing: green: system ready for operation / yellow: Fault / flashing yellow: Mains power failure
Status contacts (outputs)		optional additional board "status contacts": potential-free status for alarm, fault, window OPEN
Networking of several control units		forwarding of the alarm via additional PCB "status contacts" possible

**FUNCTIONS**

**E 260 N8/2**

Modes of operation for drive supply		standard drive
Safety functions	Line monitoring	line monitoring for alarm and drive lines using line terminal resistors
	Reaction in the case of power failure	-
	Reaction in the case of faults	-
	Vent switch	self-locking. dead-man operation possible using special wiring
Comfort functions	Automatic ventilation mechanism	-
	Maintenance / service	-
	Other	-
Smoke and heat extraction functions	Direction of alarm travel	direction of travel of the drives can be set in the case of an alarm (simple change of jumper)
	Smoke detector reset	reset button on the control unit
	Fire alarm system function	fire alarm system signal in self-locking function
	Alarm re-initiation according to VdS 2581	re-initiation always active

**CERTIFICATES / TESTS**

**E 260 N8/2**

Tested in accordance with DIN EN 12101-10

**ORDER INFORMATION**

Designation	Version	ID no.
E 260 N8/2 Control of the individual components of a smoke and heat extraction system in max. two groups with a total output power of 7.5 A	grey	100617

**ACCESSORIES**

Status contacts for E 260 N2-N32 Status contacts for "Window OPEN", "Alarm", "Fault"	078111
-----------------------------------------------------------------------------------------	--------

# Possible combinations of control panels with on-site systems

## SMOKE AND HEAT EXTRACTION SYSTEM COMBINED WITH A SHADING SYSTEM

Depending on the constructional design, windows and shades may collide when both are activated at the same time. A sequence control <sup>1)</sup> is required for this combination. This control should ensure that the windows do not open when the shading is closed and vice versa the shading should not darken (go down) as long as the windows are open.

The system could be configured as follows:

When the windows are opened in the event of an alarm, the emergency power control unit sends an alarm signal to the shading system to open it. The window drive can only begin (window opens) once the on-site limit switch on the shading system has signalled to the control that the shading system has reached its open position. Similarly, in the event of ventilation, the opening of the windows is blocked until the shading system has reached its open position. The situation is reversed for closing: the shading system can only darken after a limit switch on the window signals to the control that the windows are closed. If no signals are sent to the window or shading system, the shading system remains open and the windows closed.

## SMOKE AND HEAT EXTRACTION SYSTEM COMBINED WITH MECHANICAL SMOKE REMOVAL

Mechanical smoke removal works independently of a natural smoke extraction system. However, there are buildings which achieve smoke removal using ventilators and fresh air via natural smoke and heat extraction. For example, ventilators should only start up when the fresh air windows are open (to avoid partial vacuum). In this case, the control panel sends a potential-free signal to the fans, which can be delayed by a time relay, for example. Alternatively, end position contacts on the window can also enable automatic smoke extraction. <sup>2)</sup>

## CONNECTION OF CONTROL PANELS TO A FIRE ALARM SYSTEM/BUILDING MANAGEMENT SYSTEM

GEZE smoke and heat extraction systems can be connected to on-site systems via potential-free contacts. <sup>3)</sup>

### Examples:

- Alarm function (a fire alarm system triggers the control panel)
- Fundamentally, there should always be at least one SHEV button connected in addition.
- If necessary, smoke detectors can be connected to the control panel in addition to the on-site system.
- For “ALARM OPEN” a potential-free N/O contact of the on-site system is connected to a signal line of the control panel (pulse signal is sufficient, heed line monitoring and alarm resistance).
- For “CLOSE/RESET after alarm” a potential-free closer contact is connected parallel to the “CLOSE button” in series with the existing SHEV buttons. (Pulse signal is sufficient, heed line monitoring and alarm resistance). Alternatively (except with E 260 N) automatic resetting of the alarm can be activated at the control panel as soon as the signal line is at rest again. (Permanent signal necessary.)

### Ventilation function (the building management system forwards ventilation signals to the control panel)

- only OPEN/CLOSE without STOP: Per ventilation group, a potential-free N/O contact is connected to the vent switch input for the OPEN direction and CLOSE direction. A pulse signal is sufficient.
- OPEN/CLOSE and STOP: Per ventilation group, a potential-free N/O contact is connected to the vent switch input for the OPEN direction and CLOSE direction, and a potential-free N/C contact is connected for STOP. The ventilation function STOP is only available with E 260 N.
- OPEN/CLOSE and STOP with dead-man function (configuration of control unit necessary): Per ventilation group, a potential-free N/O contact is connected to the vent switch input for the OPEN direction and CLOSE direction. The drives are activated for the length of time the contact is closed and stopped when the contact is opened.

### Rain/wind control (on-site weather signal)

- A potential-free N/O contact is needed for rain/wind control. As long as this signal is pending, the ventilation functions are without effect.

### Feedback to the building management system

Depending on the control panel used, an additional PCB “status contacts” (E 260 N) or an ERM relay module (MBZ 300) incl. configuration by software can be necessary. This means the following signals are available potential-free as N/C or N/O contacts:

- Alarm, active after alarm has been triggered via SHEV button, smoke detector or fire alarm system
- Interference, as a collective fault signal for all interference which can be recorded
- Window OPEN or vent signal OPEN

1) Not a ready-made unit: depending on the control panel, requirements and technical circumstances, different realisation options can result. (Coordination of the needed potential-free contacts and shading control required. On-site wiring via relay may be necessary.)

The reliability must be guaranteed. The system must be coordinated with the fire protection planner responsible.

2) Depending on the control panel, requirements and technical circumstances, different realisation options can result. The reliability must be guaranteed. The system must be coordinated with the fire protection planner responsible.

3) Depending on the control panel, requirements and technical circumstances, different realisation options can result. Individual adaptation possible through configuration (with THZ / THZ Comfort through service buttons / ST 220 or MBZ 300 via configuration software). The reliability must be guaranteed. The system must be coordinated with the fire protection planner responsible.







## WINDOWS

# Networking

In the area of window technology, the IQ box KNX interface module enables controlled, natural ventilation plus the direct integration of window drives of the GEZE IQ windowdrive series into KNX building systems. IQ box KNX accesses the intelligence of the window drives and reports information such as the opening width to the building management system. Additional sensors, for instance, for measuring air quality, rain, wind and window protection, can be integrated into these system solutions under KNX. Thus, the automated windows can be intelligently controlled and monitored, and networked with shading, heating and air conditioning.



# IQ box KNX



Interface module for connecting the Slimchain, Powerchain and E 250 NT window drives in the KNX building bus

## AREAS OF APPLICATION

- Natural ventilation in façades and the roof area
- Direct connection of GEZE Slimchain, Powerchain, E 250 NT drives to KNX building systems
- For top hat rail or flush-mounted installation

## PRODUCT FEATURES

- Activation and feedback of the window drives via the KNX building bus
- One IQ box KNX per window connects up to four window drives and two locking drives
- All drives from the GEZE IQ windowdrive series can be combined and integrated according to the planning status
- Greater efficiency for building monitoring thanks to reliable status reports
- Integrated push button interface to connect components such as push buttons and sensors
- Status report from every automated window possible
- Easy to retrofit, can be extended as required



**TECHNICAL DATA****GEZE IQ box KNX****GENERAL INFORMATION**

Dimensions	50 x 45 x 19 mm (IQ box KNX flush mounting) 98 x 62 x 18 mm (IQ box KNX top hat rail)
------------	------------------------------------------------------------------------------------------

**ELECTRICAL DATA**

Operating voltage	24 V ± 25 %
Current consumption	0.02 A
Cable dimensions	max. 1,5 mm <sup>2</sup>
Temperature range	-5 – 70 °C
IP rating / protection rating	IP20 / III

**SPECIFICATIONS**

Type of installation	Surface or flush-mounted housing
Max. cable length to push button	30 m
Max. cable length to window	50 m

**FUNCTIONS**

KNX movement commands	Open/close, step/stop, target position in %, speed in %, block
KNX status reports	Position in %, opened, closed, not closed, opening, closing, intermediate position
Ventilation	Timed ventilation, gap ventilation, wind alarm, rain alarm

**IQ BOX KNX HS****IQ BOX KNX FLUSH MOUNTING WITH GEZE SLIMCHAIN CHAIN DRIVE****SYSTEM STRUCTURE**

## ORDER INFORMATION

Designation	ID no.
IQ box KNX UP Flush mounting variant for the installation in a flush-mounted branch box or electronic box	164443
IQ box KNX HS Top hat rail variant for installation on a TS35 top hat rail. Space needed 18 mm (1 TE)	164437
<b>ACCESSORIES</b>	
Surface-mounted housing Dimensions: W x H x D = 193 x 130 x 82 mm. For electronic top hat rail components, e.g. power supplies.	152010
Vent switch LTA-24-AZ with control keys "Open-Close" and LED function display (not suitable for 230 V)	129393
Vent switch LTA-LSA with rotary button for "open-close", can alternatively be used as a vent switch	118476
Power supply NT 1.1 A-24 V flush mounting Installation in flush-mounted socket	151426
Power supply NT 1.5 A-24 V HS Output voltage 21.6 - 26.4 V DC, W x H x D: 78 x 93 x 56 mm, installation on top hat rail	151425
Power supply NT 2.5 A-24 V HS Output voltage 21.6 - 26.4 V DC, W x H x D: 78 x 93 x 56 mm, installation on top hat rail	151424
Power supply NT 4.2 A-24 V HS Output voltage 24-29 V DC, W x H x D: 100 x 93 x 56 mm, installation on top hat rail	151423

# Housing, push button



**GEZE surface-mounted housing**  
(152010)



**GEZE vent switch LTA-24-AZ**  
(129393)



**GEZE vent switch LTA-LSA**  
(118476)









WINDOW

# Accessories

Our extensive range of accessories offers the right solution for every application. Whether for alarm triggering in smoke and heat extraction systems or wireless control of ventilation windows – GEZE has the right accessories. The GEZE synchronising units ensure fast commissioning and configuration of our drives. When it comes to safety at the window, then our sensors and safety scissor stays are used. Further accessories can be found on our website.



# Smoke and heat extraction system

## MANUAL ALARM ACTIVATION

### SHEV button FT 4/24 V DC-VdS

The FT 4 SHEV buttons with push-button locking are designated for manual alarm activation in case of fire. The surface-mounted housing is made from stable diecast aluminium with a replaceable glass pane in compliance with DIN 14655. Due to its considerably higher protection against vandalism, the housing offers clear quality advantages and is therefore particularly recommended for public buildings and facilities.

- Clearly traceable, identifiable release by engagement of the push button
- Reset button for resetting the alarm
- With LED operating status displays
- Surface-mounted installation

### GEZE SHEV button FT 4 K

The FT 4 K SHEV buttons are designated for manual alarm activation in case of fire. The surface-mounted housing is made of sturdy plastic with a replaceable glass pane.

- Switching power max. 100 mA 24 V DC
- Reset button for resetting the alarm
- LED displays for: Alarm, window OPEN/CLOSE, operation OK and interference

### Installation recommendation

Distance of push button switch from floor  $1.4 \pm 20$  cm. Easily visible in stairwell or corridor.  
The SHEV button must not be concealed by door leaves.

## AUTOMATIC ALARM ACTIVATION

### Smoke detector RM 1003/24 V DC-VdS

The automatic smoke detector type 1003 with VdS approval operates according to the principle of optical scattered light and is used for automatic triggering of the smoke and heat extraction system in case of fire. With VdS approval.

Dimensions: 42 mm x dia. 102 mm, weight 120 g

- Air velocity in compliance with DIN EN 54 Part 7
- Operating voltage 8 V to 30 V
- Individual display with red LED
- Operating ambient temperature -20 to 60 °C

→ **Note:** Smoke detectors should not be used if operating interference such as dust, smoke or vapour is to be expected.

### Heat detector WM 1005/24 V DC-VdS

The heat detector type 1005 with VdS approval operates according to the functional principle of the semi-conductor temperature sensor. The response variables are temperature rise and temperature limit value of the ambient temperature. With VdS approval:

Dimensions: 42 mm x dia. 102 mm, weight 120 g

- Operating voltage 8 V to 30 V
- Individual display with red LED
- Operating ambient temperature -20 to 60 °C

→ **Note:** Heat detectors should not be used if rapid temperature fluctuations are to be expected due to operating conditions.

## ORDER INFORMATION

Designation	Version	ID no.
Smoke detector RM 1003, 24V DC with base	white RAL 9016	112877
Heat differential detector WM 1005, 24 V DC, with base	white RAL 9016	112878
SHEV button FT 4/24 V DC VdS recognised	orange RAL 2011	099561
SHEV button FT 4, 24 V DC	red sim. to RAL 3000 blue RAL 5015 grey RAL 7035 yellow RAL 1021	106380 106381 106382 106885
SHEV button FT 4, plastic housing, 24 V DC	orange similar to RAL 2011	136232

# Push button, detector



**SHEV button FT 4/24 V DC-VdS**  
(099561)



**GEZE FT 4 K SHEV button**  
(136232)



**Smoke detector**  
**RM 1003/24 V DC-VdS** (112877)



**Heat detector**  
**WM 1005/24 V DC-VdS** (112878)

# Ventilation

## PUSH BUTTON

### AS 500 vent switch LTA-24 (118473)

- 24 V mains voltage
- Triple switch
- With control keys "open-stop-close"
- With LEDs to display "open-close"

### AS 500 vent switch LTA-24-SCT (127176)

- 24 V mains voltage
- Triple switch
- With control keys "open-stop-close"
- With LEDs to display "open-close"
- Combined with key switch
- Double frame

### AS 500 vent switch LTA-230-SCT (118475)

- 230 V
- 3 positions
- With control keys "open-stop-close"
- Combined with key switch
- Double frame

### AS 500 vent switch LTA-230 (118474)

- AS 500 vent switch LTA-230**
- 230 V
- Triple switch
- With control keys "open-stop-close"

### AS 500 vent switch LTA-LSA (118476)

- 230 V
- Triple switch
- With control keys "open-close"
- With optional touch or hold-open function

### AS 500 vent switch LTA-24-AZ (129393)

- 24 V mains voltage
- Double switch
- With control keys "open-close"

### SCT key switch (117996, 118478)

- Supplied without Euro profile cylinder
- Single or 2-pin version available

## SWITCH/BUTTON RANGE

ID	Name	Description	24V supply				230 V supply		Wireless range (24 V/230 V)
			MBZ 300	THZ/THZ Comfort	E 260 N	direct (IQ window-drive)	direct (conv. 230 V-drives)	direct (IQ window-drive)	
118473	LTA-24	with STOP and LEDs	-	-	●	-	-	-	-
118474	LTA-230	with STOP	-	-	●	-	●***	-	-
127176	LTA-24-SCT	with STOP and LEDs + key	-	-	●	-	-	-	-
118475	LTA-230-SCT	with STOP + key	-	-	●	-	●***	-	-
118476	LTA-LSA	switch or push button	○**	○**	-	○** + IQ gear	● (as switch)	○** (+ IQ gear + NT)	○**
129393	LTA-24-AZ	OPEN, CLOSE with LED	●	●	-	●* + IQ gear	-	●* (+ IQ gear + NT)	●*
117996	SCT single-pin	1-pin key switch	in connection with another push button						
118478	SCT 2-pin	2-pin key switch	○	○	-	○	○	○	○

● = Standard solution | ○ = Limited use possible | \* = Without use of LEDs | \*\* = As push button without stop function | \*\*\* = with latching module or E 212R | NT = power supply unit



## WIRELESS PROGRAMME

The wireless activation of doors and windows using the GEZE wireless programme makes connection to a mains power supply superfluous. Thanks to the very small dimensions of the radio modules, they can easily be integrated in the drive or in a flush-mounted socket.

Examples for areas of application:

- Retro-fitting without needing to lay cables and using existing switches/push buttons
- Installation without connection to power, for example, on glass
- Individual or group control of windows and doors
- Combined activation of doors and windows using a remote control

### Remote control

For wireless activation of doors and windows, as multi-channel solution.

For each additional channel, another terminal can be switched by pressing a button.

### Receiving module

- Simple teach-in with acoustic feedback
- Up to 85 transmitting modules to teach-in
- DIP switches for selecting mode of operation of the receiving modules (pulse mode, pulse and continuous operation)
- 2 relay outputs for individual possible connections

## ACTIVATION GEZE IQ WINDOWDRIVE

### IQ gear

The IQ gear is an interface for the activation of GEZE IQ windowdrive drives in ventilation mode in combination with power supplies and push buttons. The IQ gear converts the switching signals of the push-button into an analogue voltage. This analogue voltage is evaluated by the drive control units. Opening, closing and stop activations are then executed depending on configuration.

- For activation of the GEZE IQ windowdrive Slimchain, Powerchain and E 250 NT chain drives in ventilation mode
- Manual activation via push-button or automatic activation via potential-free contacts
- Interface between vent switch, power supply unit and window drive
- Activation of up to 10 drives in a group with one IQ gear
- Use of 24 V standard power supply units and vent switches for open / stop / close control of the drives

	IQ gear
Supply voltage	24 V DC (20–30 %)
Induced current intake	12 mA
Output signal	6–8 V, $\pm 5\%$ , analogue voltage signal for activation of the IQ windowdrives
Connection wires	0.25 mm <sup>2</sup> , PVC length approx. 150 mm
Dimensions (W x H x D) [mm]	29 x 25 x 8
Service temperature	-10 – 60 °C
Version	Printed circuit board with cast

## COMPONENTS IN THE SYSTEM

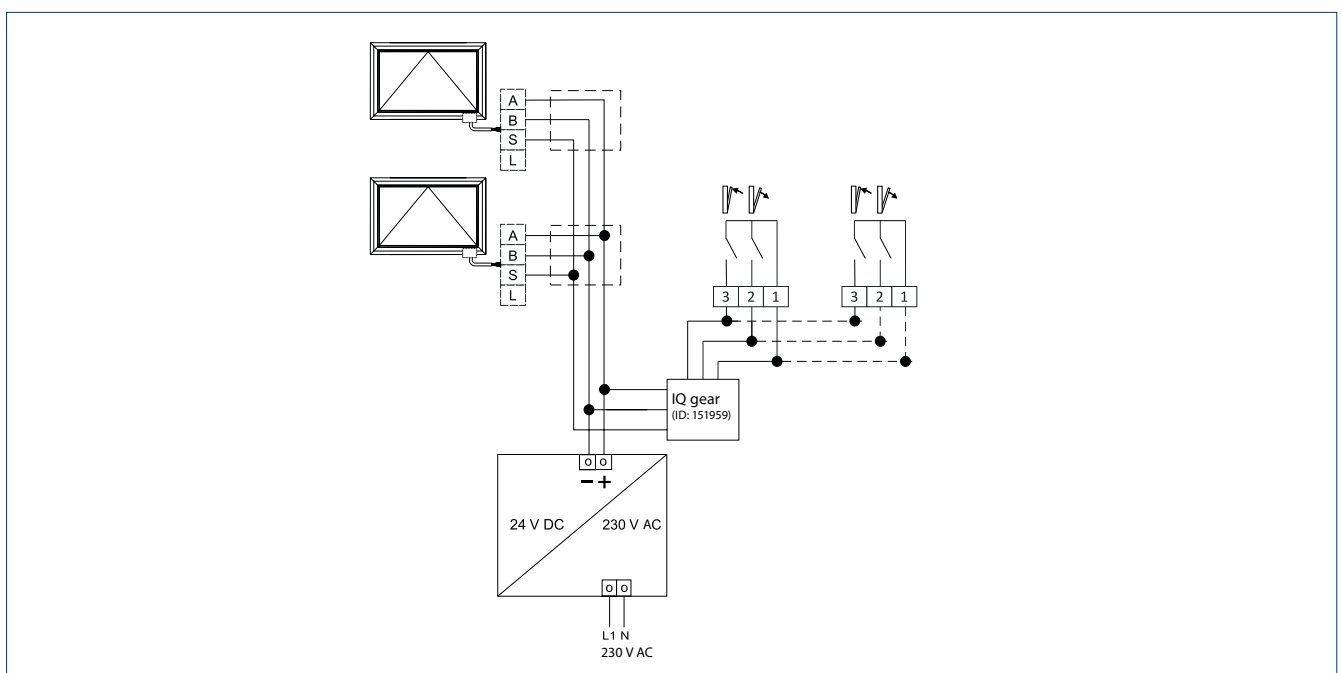

## ORDER INFORMATION

Designation	Version	ID no.
Vent switch, convertible to vent switch LTA-LSA with rotary button for "open-close", can alternatively be used as a vent switch	alpine white	118476
Vent switch LTA-230 with control keys "open-stop-close"	alpine white	118474
Vent switch combined with key switch LTA-230-SCT with control keys "open-stop-close"	alpine white	118475
Vent switch LTA-24 with control keys "open-stop-close" and LED function display (only suitable in combination with E 260 N)	alpine white	118473
Vent switch LTA-24-AZ with control keys "Open-Close" and LED function display	alpine white	129393
Vent switch combined with key switch LTA-24-SCT with control keys "open-stop-close" and LED function display	alpine white	127176
SCT key switch 1-pin without Euro profile cylinder	alpine white	117996
SCT key switch 2-pin without Euro profile cylinder	alpine white	118478
WRM-230 receiving module 52 x 47 x 23 mm (W x H x D), for installation in a standard flush-mounted box		131215
WRM-230B receiving module 130 x 80 x 35 mm (W x H x D), for surface-mounted installation with protection class IP 54		131216
WRM-24 receiving module 52 x 47 x 23 mm (W x H x D), for installation in a standard flush-mounted box		131213
Receiving module WRM-24B 130 x 80 x 35 mm (W x H x D), for surface-mounted installation with protection class IP 54		131214
Remote control 2 channels with wall fixing and IP rating IP54		131210
Remote control 4 channels with wall fixing and IP rating IP54		131211
WTM transmitting module 44 x 30 x 11 mm (W x H x D), for optional integration in push-button		131212
IQ gear		151959
Power supply NT 1.1 A-24 V flush mounting		151426
Power supply NT 1.5 A-24 V HS		151425
Power supply NT 2.5 A-24 V HS		151424
Power supply NT 4.2 A-24 V HS		151423

# Switches, wireless programme, IQ gear



**AS 500 vent switch LTA-24**  
(118473)



**AS 500 vent switch LTA-24-SCT**  
(127176)



**AS 500 vent switch LTA-230-SCT**  
(118475)



**AS 500 vent switch LTA-230**  
(118474)



**AS 500 vent switch LTA-LSA**  
(118476)



**AS 500 vent switch LTA-24-AZ**  
(129393)



**Key switch SCT**  
(117996, 118478)



**Remote control 2 channels**  
(131210)



**Remote control 4 channels**  
(131211)



**WTM transmitting module**  
(131212)



**WRM receiving module**



**IQ gear**  
(151959)

# Sensors

## RAIN/WIND CONTROL

### Weather station

The weather station unit contains the rain and wind sensors. Wind is measured electrically by means of a heated ceramic wire. This eliminates the need for the usual mechanical measurement using wind blades. The rain is measured by the gold-plated printed conductors on the surface, which measure even the finest rain. If the rain/wind control is activated, the connected vent switches are blocked and all connected drives are switched on in direction "CLOSED". But an alarm has precedence over the rain/wind control, i.e. in the event of an alarm, the windows will be opened even if the rain/wind control is active (the windows are not closed). The switching point of the wind speed sensor can be set between 1 and 15 m/s.

### Control unit with evaluation electronics

The control includes the power supply device and the potential-free switching contacts with microcontroller control of the rain/wind signals.

The evaluation takes place individually or jointly. The weather station is supplied with 24 V DC/GND/signal input.

The rain/wind control can be connected to several control panels without an additional relay (loop signal through). A rain/wind control unit provided on-site by the customer can also be used; this needs a potential-free N/O contact, also installed on-site by the customer.

## MBZ 300 WEATHER SENSORS

The weather sensors can be used for

- Automatic rain/wind control of ventilation operation
- Wind direction dependant activation for SHEVs when smoke and heat extraction is needed in accordance with DIN 18232-2 and EN 12101-2

They are connected to the MBZ 300 WM weather module. The necessary values (wind thresholds, weather groups, wind directions for drive groups) are set using MBZ 300 software.

## GEZE CONTROLS AND WEATHER STATION

Control unit / Control panel	Connection	Weather station	Rain sensor GC 401 RS and wind sensor GC 402 WVS	GC 401 RS rain sensor and GC 402 WVS wind sensor and wind direction sensor GC 403 WDS
		091529	140229	140229 + 140228
MBZ 300	potential-free input on the CM or SM	for <b>ventilation</b>	–	–
MBZ 300	on the WM weather module	potential-free inputs for rain / wind for <b>ventilation</b>  (programming with MBZ 300 software with licence necessary)	with setting of maximum wind speed for <b>ventilation</b> connection without programming possible. Pre-setting of the wind threshold: 2 m/s  (change with software in view mode to 4 m/s or 6 m/s possible). Other settings via software with licence	for <b>ventilation</b> and as wind-direction-dependent activation for SHEVs (in the case of <b>smoke and heat extraction</b> )  (programming with MBZ 300 software with licence needed)
THZ/THZ Comfort	potential-free input	for <b>ventilation</b>	–	–
E 260 N	potential-free input	for <b>ventilation</b>	–	–
E 202 Z1 (230V)	potential-free input	for <b>ventilation</b>	–	–
230V direct	potential-free input	for <b>ventilation</b>	–	–

## E 70 ROOM TEMPERATURE REGULATOR

The E 70 room temperature regulator is used for control in interior rooms. The temperature switching point can be individually set between 5 and 30 °C.

**ORDER INFORMATION**

Designation	ID no.
GC 401 RS - rain sensor Use with the MBZ 300 weather module	140226
GC 402 WVS - wind speed sensor Use with the MBZ 300 weather module	140227
GC 401 RS + 402 WVS - wind and rain sensor set Use with the MBZ 300 weather module	140229
GC 403 WDS - wind direction sensor Use with the MBZ 300 weather module	140228
E 70 room thermostat for dry closed rooms setting of two switching points	079087
Rain / wind control Consisting of weather station and output control unit: potential-free contacts for rain/wind	091529
<b>ACCESSORIES</b>	
Relay with base 230 V	008276
Switching protection E 204 G 230 V	021338

# Sensors



**Rain/wind control with weather station (091529)**



**GC 401 RS rain sensor (140226)**



**Wind speed sensor GC 402 WVS (140227)**



**GC 403 WDS wind direction sensor (140228)**



**Room thermostat E 70 (079087)**

# Power supplies

GEZE power supplies are suitable for 230 V ventilation applications with IQ windowdrive. A corresponding power supply, an IQ gear and a vent switch are needed for the activation of the 24 V IQ windowdrive. Depending on power requirements for the drives and their division into groups, different power supplies can be selected:

	GEZE POWER SUPPLY NT 4.2 A – 24 V HS	GEZE POWER SUPPLY NT 2.5 A – 24 V HS	GEZE POWER SUPPLY NT 1.5 A – 24 V HS	GEZE POWER SUPPLY NT 1.1 A – 24 V UP
Supply voltage	230V AC			
Performance	100.8 W	60 W	36 W	26.4 W
Output voltage	24 – 29 V DC ±1 % adjustable		21.6 – 26.4 V DC ±1 % adjustable	24 V DC ±5 % fixed
Output current	4.2 A	2.5 A	1.5 A	1.1 A
Connection	Screw terminals 2.5 mm <sup>2</sup>			2 x 2 wire cores, 0.5 mm <sup>2</sup> approx. 90 mm long
Dimensions (W x H x D)	100 x 93 x 56 mm	53 x 90 x 55 mm	35 x 90 x 55 mm	Diameter 54 mm, 32.5 mm high
Service temperature	-10 – 50 °C			
Version	top hat rail casing			Flush-mounted housing for installation in a deep flush-mounted installation box

## ASSIGNMENT TABLE: NUMBER OF WINDOWS PER POWER SUPPLY FOR VENTILATION APPLICATIONS

Opening system	NT 4.2	NT 2.5	NT 1.5	NT 1.1 (flush mounting)
Slimchain SO	5	3	1	1
Slimchain SO + Power lock	3	1	1	
Slimchain SY	2	1		
Slimchain SY + Power lock	2	1		
Slimchain SY3	1	1		
Slimchain SY3 + Power lock	1	1		
Powerchain SO	3	2	1	
Powerchain SO + Power lock	3	1	1	
Powerchain SY	2	1		
Powerchain SY + Power lock	2	1		
Powerchain SY3	1			
Powerchain SY3 + Power lock	1			
E 250 NT SO	5	3	1	1
E 250 NT SO, stroke 500	3	1	1	1
E 250 NT SO + Power lock	3	1	1	
E 250 NT SY	2	1		
E 250 NT SY, stroke 500	2	1		
E 250 NT SY + Power lock	2	1		
E 250 NT SY3	1	1		
E 250 NT SY3, stroke 500	1			

SO = Solo | SY = Syncro

→ **Note:** The cable cross-section between drive and power supply is calculated according to the equation: Cable cross-section = Cable length x total current of the drives / 73

**ORDER INFORMATION**

Designation	ID no.
Power supply NT 4.2 A – 24 V HS	151423
Power supply NT 2.5 A – 24 V HS	151424
Power supply NT 1.5 A – 24 V HS	151425
Power supply NT 1.1 A – 24 V flush mounting	151426

# Power supplies



**Power supply NT 4.2 A – 24 V HS**  
(151423)



**Power supply NT 2.5 A – 24 V HS**  
(151424)



**Power supply NT 1.5 A – 24 V HS**  
(151425)



**Power supply NT 1.1 A – 24 V flush mounting** (151426)

# Surface-mounted housing

The GEZE surface-mounted housing is an aesthetic alternative to a conventional surface-mounted installation box. It is white and has an attractive design making it less conspicuous on the wall.

The housing is used to house electronic top hat rail components e.g. power supplies if these cannot be installed in control cabinets in technical rooms or in flush-mounted boxes. Thanks to the clever

design, the four housing parts can be simply plugged together without tools. This way, several housings can be coupled together in order to house several components. For safety reasons, dismantling can only be done with a screwdriver.

## TECHNICAL DATA

Version	White plastic housing with pre-installed top hat rail
Line-feed	Surface mounting with the aid of insertion plugs or flush mounting possible
Area of application	Dry rooms, installation on walls or ceilings
Dimensions (W x H x D)	193 x 130 x 82 mm
Ambient temperature	-5-70 °C
IP rating	IP40
Examples of possible top hat rail construction components	GEZE power supply NT 1.5 A-24 V top hat rail GEZE power supply NT 2.5 A-24 V HS GEZE power supply NT 4.2 A-24 V HS each with IQ gear  or other top hat rail construction components with the max. dimensions (W x H x D) [mm]: 119 x 93 x 53

## ORDER INFORMATION

Designation	ID no.
Surface-mounted housing	152010

# Surface-mounted housing



Surface-mounted housing  
(152010)



Surface-mounted housing, cascaded  
(152010)



# Marking and signalisation

## Signal horn (072112)

For acoustic alarm indication  
 Surface- or flush-mounted installation  
 Dimensions for surface mounting (dia. x H)  
 111 x 25.5 mm  
 Dimensions for flush mounting 81 x 81 x 62.5 mm  
 26 settings for signal tone  
 Signal horn 24 V DC

## Flashlight (089353)

For optical alarm indication  
 Surface-mounted installation  
 Dimensions (ø x H) 93 x 72 mm

## Information labels

Dimensions (H x B x D) 52 x 148 x 1 mm  
 Plastic, not adhesive

## ORDER INFORMATION

Designation	Version	ID no.
"Ventilation" information label		025647
"Smoke extraction" information label		005158
BLE 220 flashlight AP	red	089353
SLH 220 signal horn AP	white	072112

## Signal horn, flashlight, information label



SLH signal horn (072112)



BLE 220 flashlight (089353)

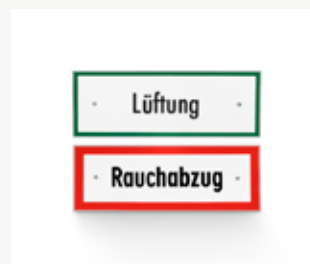

Information label ventilation (025647)  
 Information label smoke extraction (005158)

# Safety scissor stays

When drives are used for activating bottom-hung windows (open/close), there is a potential danger of the window leaves falling out. For this reason, GEZE prescribes the compulsory use of separate GEZE safety scissor stays, which are not connected with the drive. GEZE safety scissor stays ensure that a permanent fixed connection between the frame and leaf is guaranteed – independently of the drive. The driven bottom-hung window is only safely protected against falling out when GEZE safety scissor stays (type 35 or type 60) are used. The bottom-hung window must not be operated if the safety scissor stays are missing.

Falling window leaves can be a significant danger for the life and limb or persons near the window. For this reason, the use of GEZE safety scissor stays is compulsory when GEZE drives are used on bottom-hung windows.

Therefore, the safety scissor stays serve as fall protection and can be used on vertically installed bottom-hung windows made of aluminium, PVC and wood.

## Note:

- The GEZE processing and installation guidelines must be observed during installation of the scissor stays.
- Two scissor stays must always be installed!
- The relevant supports must be used to ensure secure fixing.
- For details of the permissible leaf weights and fitting dimensions, please refer to installation instructions no. 134433 and installation drawing 41314-EP-001

## GEZE gripping and cleaning scissor stay (FPS)

In the case of bottom-hung leaves, safety units must be used in addition to the fanlight opener. These limit the tilting movement of the leaf after the opening scissor stay has been disengaged and prevent the leaf becoming a hazard during cleaning. For this purpose, GEZE supplies the “intelligent” gripping and cleaning scissor stay (gripping position) for vertically installed bottom-hung leaf rectangular windows.

## SAFETY SCISSOR STAYS – INSTALLATION

### DETERMINATION OF INSTALLATION DIMENSION X FOR SAFETY SCISSOR STAY NO. 35 FOR-OPENING WIDTHS 200, 300, 400, 500, 600 AND 700 MM

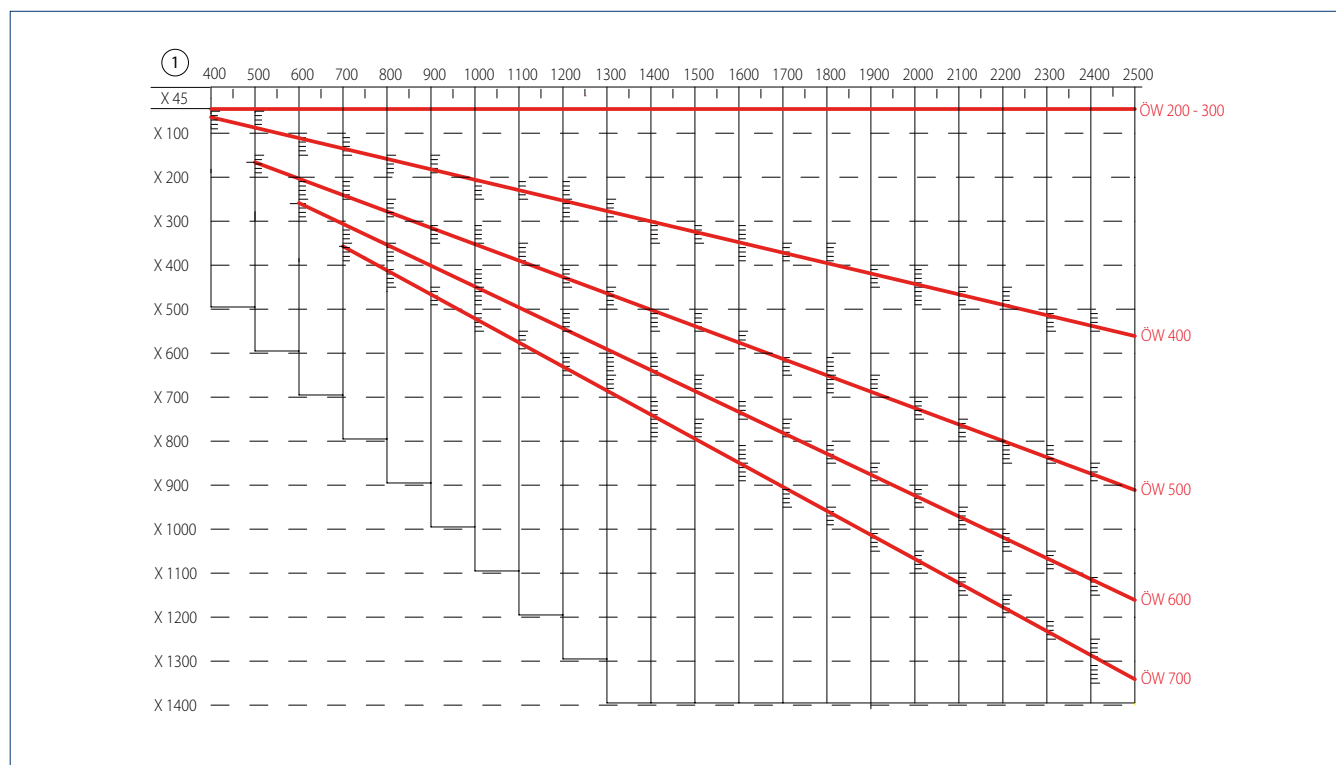

ÖW = Opening width | X = Installation dimension | 1 = Leaf height

**LEAF WEIGHT (MAX.) IN KG FOR DETERMINED DIMENSION X AND SPECIFIED OPENING WIDTH  
FOR 2 SAFETY SCISSOR STAYS NO. 35 PER WINDOW**

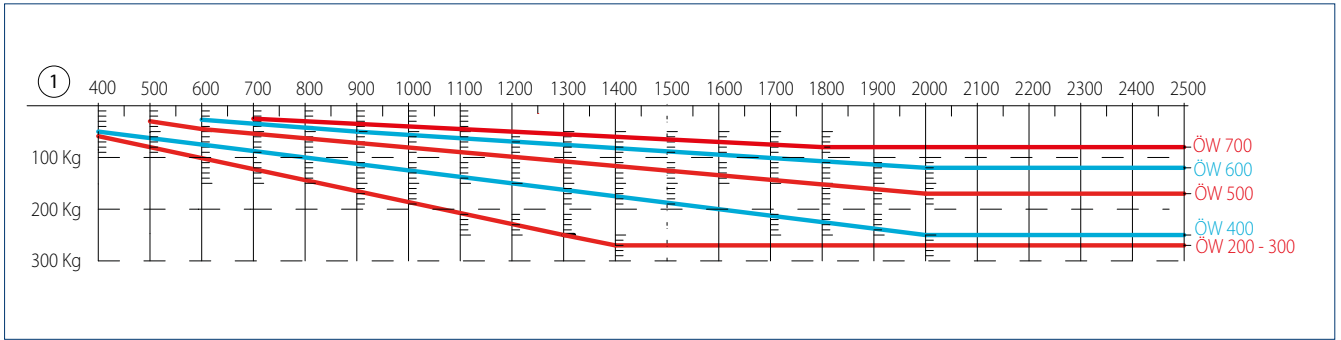

ÖW = Opening width | l = Leaf height

**DETERMINATION OF INSTALLATION DIMENSION X FOR SAFETY SCISSOR STAY NO. 60  
FOR-OPENING WIDTHS 500, 600, 700, 800, 900, 1000 AND 1200 MM**

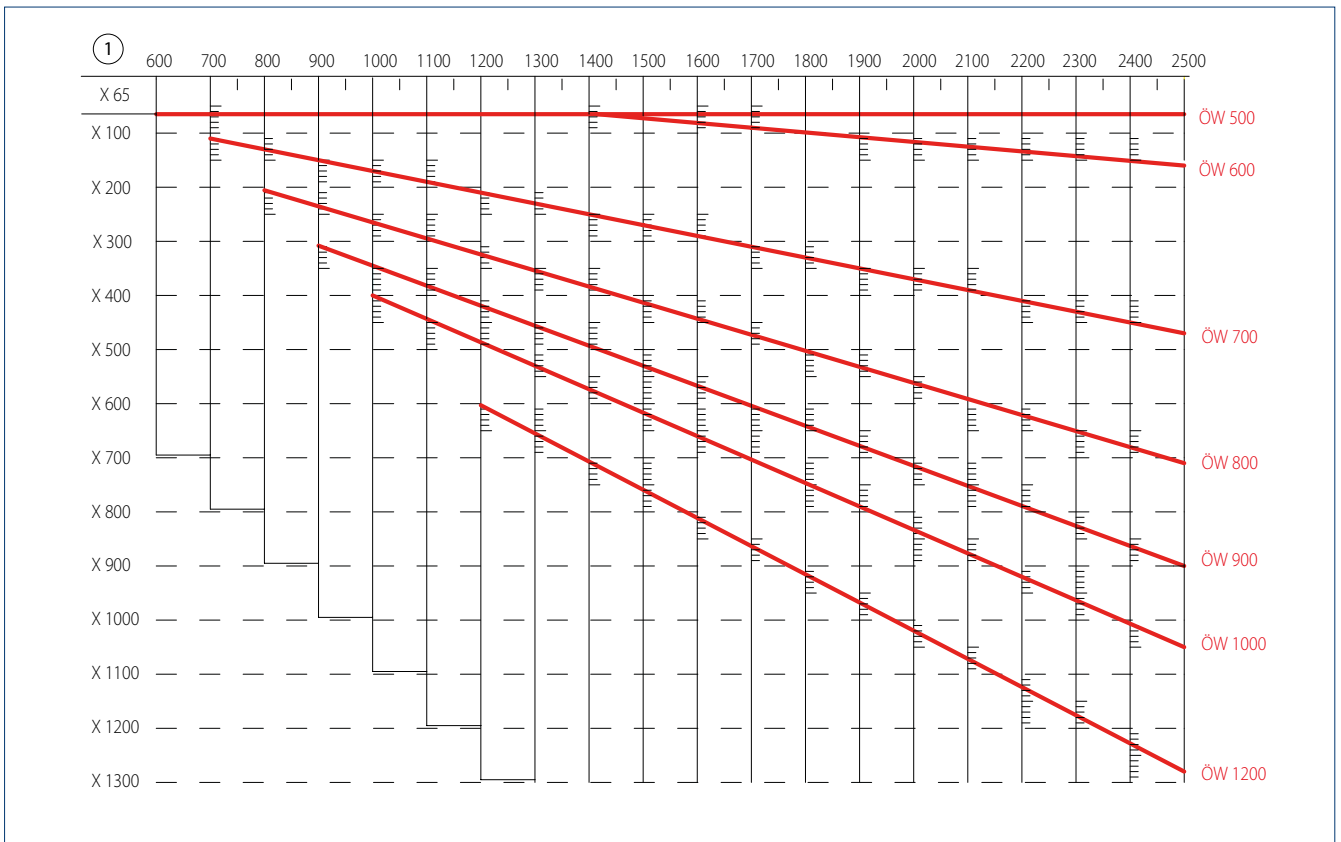

ÖW = Opening width | X = Installation dimension | l = Leaf height

**LEAF WEIGHT (MAX.) IN KG FOR DIMENSION X DETERMINED AND  
GIVEN-OPENING WIDTH FOR 2 SAFETY SCISSOR STAYS NO. 60 PER WINDOW**

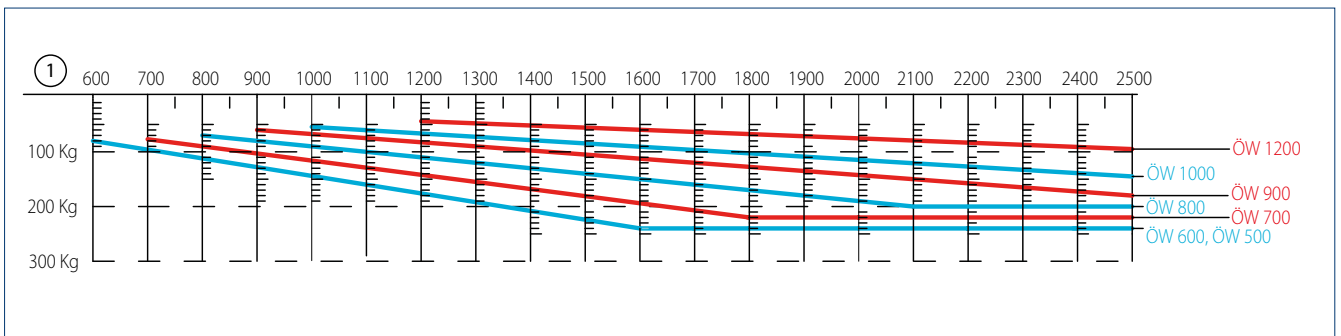

ÖW = Opening width | l = Leaf height

## ORDER INFORMATION

Designation	Version	ID no.
Safety scissor stay no. 35	galvanised	014499
Safety scissor stay no. 60	galvanised	133814
Gripping and cleaning scissor stay (FPS) FPS 340 closing force 1	galvanised	030249
Gripping and cleaning scissor stay (FPS) FPS 520 closing force 2	galvanised	030250
Gripping and cleaning scissor stay (FPS) FPS 720 closing force 3	galvanised	030251
<b>ACCESSORIES</b>		
Mounting plates for gripping and cleaning scissor stay For aluminium windows (mounting fittings for leaf and frame)		030252
Mounting plates for gripping and cleaning scissor stay for PVC windows (mounting fittings for leaves with Euro groove and frame)	galvanised white	070182 030253
Frame shims for gripping and cleaning scissor stay for PVC windows	3 mm 5 mm	029334 029335
Frame shims for gripping and cleaning scissor stay for PVC windows with inclined rebate		030383
Leaf shims for gripping and cleaning scissor stay	4 mm 5 mm 7 mm 8 mm 9 mm	009324 009325 013305 025635 009321
Frame shims for gripping and cleaning scissor stay aluminium windows	3 mm 5 mm	009326 009328
Stop gauges for gripping and cleaning scissor stay (FPS)		024741
Frame or leaf shim	7 mm 8 mm 9 mm 5 mm	135013 135012 135011 135014
Leaf shim		135015
Frame shim	5 mm 3 mm 5 mm 3 mm	135016 135017 135019 135018
Frame shim for inclined rebate		135020

# Safety scissor stays

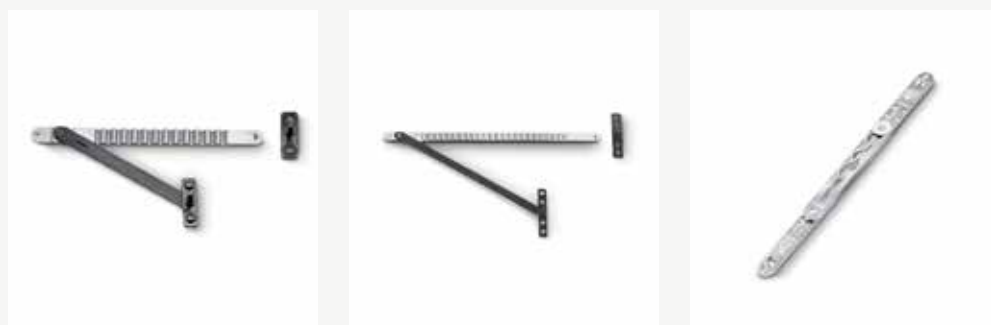

Safety scissor stay no. 35 (014499) Safety scissor stay no. 60 (133814) Gripping and cleaning scissor stay (FPS)

# Synchronising units

## Synchronising unit 230 V

This synchronising unit is suitable for all GEZE electric drives with 230 V.

## Synchronising unit E 212 R1

This synchronising unit is suitable for GEZE electric linear drives E 212 R1 and the scissor drive E 170.

## Service case

The service case has been designed especially for the simple and fast commissioning and parameter setting of IQ windowdrive.

Product features:

- Compact stand-alone solution in a handy case
- Integrated rechargeable batteries for simple commissioning of the drives even without on-site current connection
- 230 V connection for charging and permanent operation
- Alarm and ventilation mode for early “official approval” of automated windows on site
- Connecting possibility for the ST 220 service terminal for simple parameter setting for the IQ windowdrive
- Maximum output current of 5.5 A makes the commissioning of Syncro sets with several drives possible
- Ammeter for diagnosis
- Can also be used for 24 V drives without LIN bus

## ORDER INFORMATION

Designation	ID no.
Synchronising unit for GEZE electric drives with 230 V	054371
Synchronising unit for GEZE electric drive E 212 R1 230 V	026762
Service case GEZE IQ windowdrive	142586
LIN parameter setting adapter. Enables the connection of the GEZE ST 220 service terminal to the GEZE Slimchain 230 V chain drive for parameter settings via LIN-BUS	179238

## ACCESSORIES

Connection cable ST 220 mini DIN	142581
ST 220 service terminal: Parameter setting and diagnosis for TZ 320, TE 220, automatic sliding and swing door systems from DCU software V3.0 and IQ windowdrive, battery operation with 4xAA cells (not supplied by GEZE), plain text display on illuminated panel, keypad for operation	087261

# Synchronising units



Synchronising unit 230 V  
(054371)



Synchronising unit E 212 R1  
(026762)



Commissioning case  
(142586)



Service Terminal ST 220  
(087261)



LIN parameter setting adapter  
(179238)



WINDOW

# Software

Simple calculations: WinCalc, the GEZE configurator for window technology completes” the complicated calculations relating to the system design for a window: saves times, is userfriendly and convenient. Calculations are possible for manual and electromotive ventilation windows, smoke and heat extraction systems as well as SHEVs. The program performs all calculations and comes up with usable drive solutions ensuring uncomplicated planning and calculation of GEZE window technology.





# GEZE WinCalc

## THE CALCULATION PROGRAMME FOR WINDOW TECHNOLOGY

With the WinCalc calculation program, GEZE provides an additional service tool. WinCalc “completes” the complicated calculations relating to the system design for a window, and makes it easy for installation engineers and planners to find the ideal drive solution for a window. Saves time, is user-friendly and convenient. Automatic calculations and dimensioning, the option of simply comparing results and the clear presentation of results and list of items all make it easier to handle GEZE window technology products. It is possible to make calculations for manual and electrically operated ventilation and smoke dissipation windows, as well as for SHEVs. All relevant window components and combinations tested by GEZE in accordance with EN 12101-2, are stored in the SHEV calculation. All that remains to do for the user of WinCalc is to enter the dimensions of the required window. The programme then performs all the calculations, such as drive load and opening areas and outputs all the applicable drive solutions. With the help of the control panel configuration, it is also possible

to ascertain an appropriate SHEV emergency power control unit for a specific window list. The composition of the control panel (type, possible MBZ 300 modules, alarm and ventilation groups, connection of the drives) is compiled automatically. With the selected accessories, the complete smoke and heat extraction system can be presented. An interface to the GEZE system shop allows simple inquiries and ordering of the components calculated from the drive solution to control panel. WinCalc can be found on the GEZE partner portal.













# We are GEZE.

## For liveable buildings

GEZE stands for innovation, high quality and comprehensive support of building technologies. From the initial idea, planning and operational implementation with standard products to customised system solutions and individual service and maintenance plans. We offer an extensive product range of door, window and safety technology products and are a major driving force behind the digital networking of building automation.

### **GEZE GmbH**

Reinhold-Vöster-Strasse 21 – 29  
71229 Leonberg  
Germany

Telephone: +49 7152 203 0

Fax: +49 7152 203 310

Email: [info.de@geze.com](mailto:info.de@geze.com)

**[www.geze.com](http://www.geze.com)**

1911 ID no. 154851 EN Subject to change without notice